



**ANTRIEBSELEMENTE**

Shaft-hub connections



**If performance is required**

[www.luetgert-antriebe.de](http://www.luetgert-antriebe.de)



# A family owned company in the 3rd generation

TAS Schäfer GmbH is a family owned company with a long tradition. We are a company with high flexibility and leading on the market for friction locking hub to shaft connections.

In the meanwhile third family generation we have been developing innovative products for the drive technology since 1961. From our head-quarter in Wetter-Wengern we supply our high-quality products to our customers all over the world.

The sustainable support of our customers is always the most important thing for our daily work. With our agencies around the world we ensure a high standard of service. Reliability and a high level of technical consulting competence are our most important principles in the relationship with our customers.





# Modern mechanical processing in perfection



## Made in Germany

Our customer-oriented, flexible and efficient team implements customer requests quickly and professionally to find the best technical solution for our customers. We produce our products exclusively in Germany and guarantee the worldwide recognized quality „Made in Germany“.

Our engineering team is constantly working on innovative improvements to specific practice and customer requirements. Your wishes and requirements are our goal. A state of the art in-house production facility with modern CNC technology and an own quality control department guarantee high-quality products.

## Your advantages

The TAS Schäfer GmbH has more than five decades of experience in the field of machining of metals. Our machining processes mainly contain turning and drilling on modern CNC technology.

A combination of a high modern production with and the Know-how of our qualified employees makes us a reliable partner for our customers. Our strength is the high flexibility and the fast reaction time in the manufacturing process.

To make this possible a close communication takes place between our own engineering team and production.

An own raw material stock ensures short delivery times for our customers even for customized solutions.

# Certified quality for present and future

## We work for a clean future

As an ISO 9001 certified company we guarantee from the process of development to the finished product a maximum of quality and reliability. At our headquarter in Wetter-Wengern we are able to perform a detailed quality control of the manufactured products in our own quality center. With some of our products we support the effort of generating renewable energies. Wind turbines worldwide work with hydraulic or mechanical shrink discs made by TAS Schäfer GmbH. We work for a clean future.

Our technological developments for the shipping industry support the worldwide transport of goods across the oceans. Strength and endurance are not unknown for us. Our locking assemblies and flange couplings in the conveyor technology enable the mining of important raw materials, that are necessary for our daily life. According to the slogan „time is money“ we supply special solutions for test benches of wind turbine gearboxes worldwide. Exemplary for innovative product development are our hydraulic shrink discs. The to customer requirements oriented design enables the users an efficient and reliable connection and disconnection of shaft/gearbox connections. Our hydraulic products reduce costly assembly times to a minimum.

With slowing down moving masses in a safe and fast way our friction springs and industrial buffer are indispensable safety parts to protect people or conserve machines. Reliability and high quality standards are our top priorities.

**That's what we're working for every day.**







## Quality control - From development to delivery

Already with the selection of our suppliers we define high requirements to ensure our high quality standards for the needed raw material of our products.

An important part of quality control is our own measuring centre at the location Wetter-Wengern. In our quality control process the manufactured parts are checked and reviewed by our 3D measuring machine.

Thereby our highly qualified employees guarantee the consistently high quality, safety and durability of our products.

On request, TAS Schäfer-products could be manufactured with certification of a classification society or comprehensive documentation.

# Contents

Industrie overview .....	008
--------------------------	-----

## Hydraulic Actuated Products 010



SHS hydraulic shrink disc Standard .....	012
SHS hydraulic shrink disc Test Bench .....	013
SHS hydraulic shrink disc Marine .....	014
SHS hydraulic shrink disc Wind energy .....	014
SHS hydraulic shrink disc Customized .....	015
FKH Rigid flange coupling .....	017

## Shrink Discs 2-part (Torque-controlled) 018



3171 Standard-Range .....	024
3181 Standard-Range strengthened .....	028
3191 Heavy-Range .....	032
3193 Heavy-Range strengthened .....	034

## Shrink Discs 2-part (Displacement-controlled) 036



3173 Mini-Range .....	042
3371 Standard-Range .....	045
3381 Standard-Range strengthened .....	051
3391 Heavy-Range .....	056
3393 Heavy-Range strengthened .....	060

## Shrink Discs 3-part 065



3073 Mini-Range .....	070
3051 Light-Range .....	073
3051 Half/Split Light-Range .....	075
3071 Standard-Range .....	077
3071 Half/Split Standard-Range .....	080
3081 Standard-Range strengthened .....	083
3091 Heavy-Range .....	087
3091 Half/Split heavy-Range .....	089
3093 Heavy-Range strengthened .....	093
Typ 52 Suitable for Stiebel-helical-bevel gears .....	095

## Flange Coupling 097



FK Rigid flange coupling .....	101
FKE Rigid flange coupling .....	103
Hydraulic clamping tool TAS HY for FKE H .....	109
Connecting Flange AFS .....	111
AF External Clamping Element Series 12 .....	113
AF External Clamping Element Series 22 .....	115
AF External Clamping Element Series 23 .....	119



# Product catalog

## Shaft Couplings

123

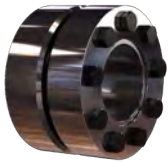

W.....	127
WK.....	131
WLA.....	135
WLB.....	139

## Internal Locking Devices

142



Hub-Calculation.....	147
3003 plus.....	151
3003.....	153
3006 plus.....	155
3006.....	157
3012.....	159
3014.....	161
RB.....	163
3015.....	165
3015.1.....	167
3015 DK.....	169
3015.1 DK.....	171
3020.....	173
4006.....	177
8006.....	181
TAS 110.....	185
TAS 130.....	187
TAS 131.....	189

## Damping Technology

191



Friction Springs.....	195
IPA 1.....	197
IPA 2.....	199
IPA 3.....	201
IPA 4.....	203

## Stainless Products

205



3171 1.4122 2-part.....	207
3071 1.4122 3-part.....	211
W 1.4122.....	213
3012 S2.....	217
3020 S2.....	219

# Typical applications

## Wind power



Our hydraulic or mechanical shrink discs are used worldwide for the connection of the hollow shaft of the transmission with the rotor shaft.



## Mining



Different versions of our flange coupling are used in bucket wheel excavators. Furthermore, our locking assemblies, shrink discs and friction springs are used in conveyor drums, stirring shaft connections and crushers.

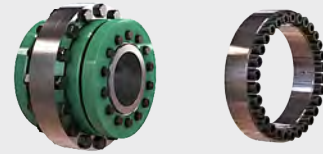

## Materials handling



In the powertrain of conveyor belts, our flange couplings are also used. Our friction springs, shrink discs and locking assemblies are used in the field of conveyor technology, especially in heavy-duty cranes, conveyor drums, elevators and storage technology.



## Marine technology



Our hydraulic or mechanical shaft coupling drive rudder and shaft systems. Furthermore, our hydraulic and mechanical shrink discs are used to connect intermediate shafts and thrust bearing connections.

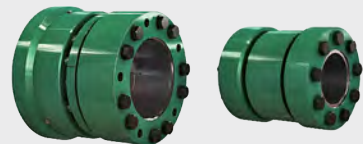

## Drive technology



Our mechanical shrink discs are used for driving cable winches. In addition, hydraulic shrink discs, flange couplings and locking assemblies are used for shaft connections, motor connections and brake discs.



## Hydropower

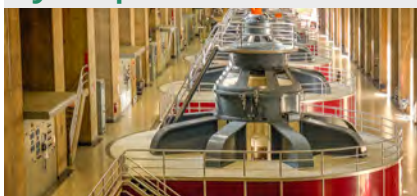

Our connections flanges are mainly installed in hydropower plants. Our locking assemblies find their application in hydropower technology, e.g. in Francis turbines. Especially, the stainless steel versions have a great importance in these applications.





# Typical applications

## Oil and gas industrie



Especially our stainless steel products are designed for extreme conditions. Shaft couplings of TAS Schäfer GmbH are used to connect gearboxes and motors. For sealing systems on pumps, our shrinks are also used.



## Wood processing



Our shrink discs from TAS Schäfer GmbH are installed in wood processing machines. A typical application is the wood transport within the machine. Depending on customer requirements, shaft couplings, locking assemblies and flange couplings are also used in this branch.



## Food industrie



Stainless steel products are standard in the Food industrie. For this reason, our stainless steel shrink discs or locking assemblies are essential for the high hygienic standards of this industrie. They provide a reliable foundation for all applications in the area. Typical applications are stirring systems, ice machines and filling machines.



## Paper industrie



Preferably, our hydraulic shrink discs are used in this industrie, this allows faster replacement of rolls.

Furthermore, mechanical shrink discs and locking assemblies are installed in rollers and winding machines.



## Packaging machines



Our locking assemblies are worldwide installed in different packaging machines.

For example, they are used to mounting pulleys and also for the transport of goods in the machines. Furthermore, shrink discs and shaft couplings are also used in this industrie.



## Gearbox test benches



Our hydraulic shrink discs, especially for gearbox test benches, are designed and manufactured to customer specifications. Through our years of know-how, we are world market leaders in this industrie and equip test benches worldwide with our products.



**TAS**  
**SCHÄFER**

# Hydraulic Actuated Products





# Description of function SHS

## Shrink discs of the type SHS

The main function of a shrink disc is the safe connection of a shaft with a hub by means of friction. For example, between a drive shaft and a transmission hollow shaft. The shrink disc generates a backlash-free connection by pressing the hub onto the shaft. This connection is mainly used to transmit torque.

The shrink disc only provides the required forces, and transfers no forces or moments between shaft and hub by itself. It is not in the force flow.

It is installed by sliding the shrink disc onto the hollow shaft and the subsequent tightening of the hydraulic system. By using conical surfaces the inner diameter reduces and the radial pressure is built up. After clamping the SHS will be locked mechanically and the hydraulic

pressure will be removed. Due to this simple approach the SHS is suitable for repetitive clamping operations as they occur on a test bench, for example.

To achieve proper operation and to a sufficiently high coefficient of friction, the contact surfaces between shaft and hub must be free of grease, dry and clean. The functional surfaces of the shrink disc are equipped at the factory with lubricant. The contact surfaces between the hub and shrink disc must also be provided with grease before installation.

### Product data SHS

#### Data sheets and CAD data:

- Our hydraulically actuated shrink discs are selected according to customer specifications or been redesigned.
- For this purpose please send us an e-mail to [info@tas-schaefer.de](mailto:info@tas-schaefer.de)

You can find the questionnaire for this product on:

[www.tas-schaefer.de](http://www.tas-schaefer.de)

### Advantages of the SHS:

- application-specific design/ customization
- relatively low pressure
- very rapid tightening / loosening, in comparison to the mechanical shrink disc
- mechanically removably, partially mechanically tensionable when hydraulic is not available
- simple design based on 3-parts shrink disc
- maintenance/repairs carried out by customer

### Hydraulics on the front

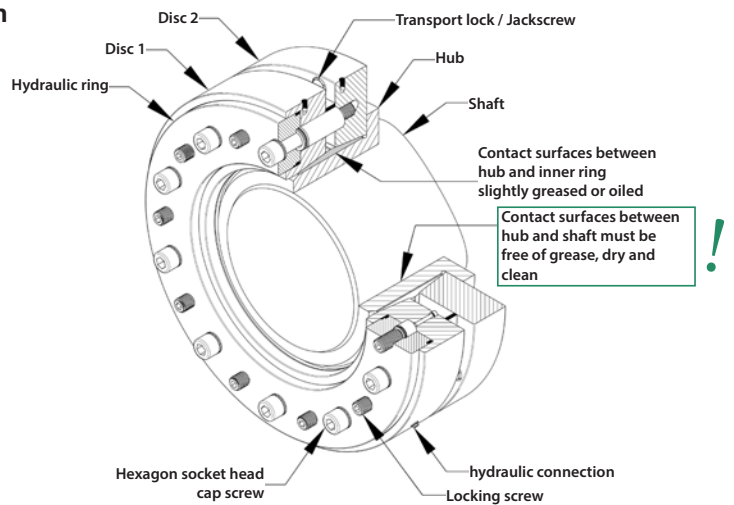

### Hydraulics on the back

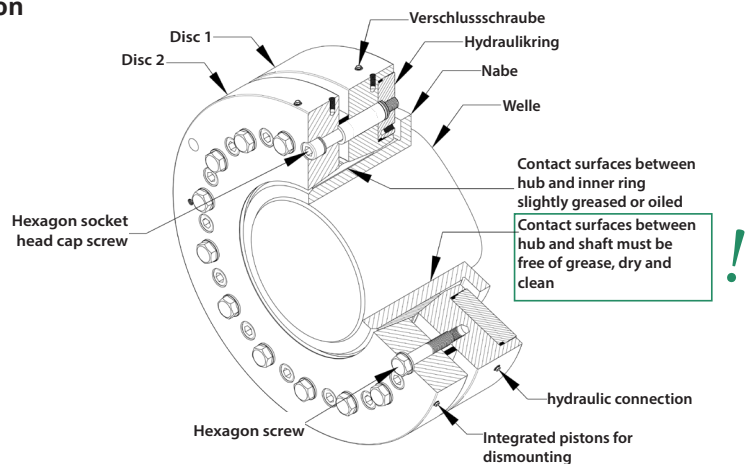

# SHS standard

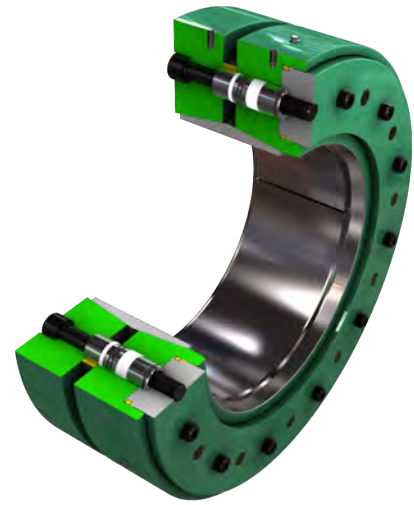

**SHS-560**

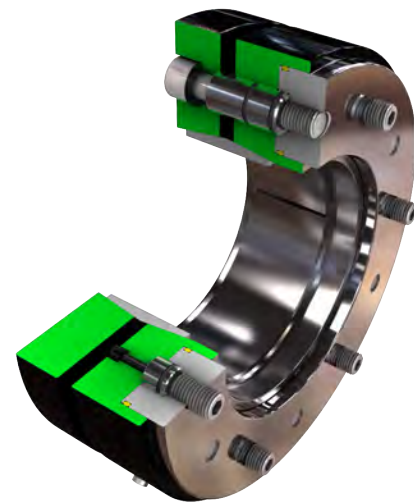

**SHS-220 MD DT**

Typical fields of application

Industrial gearboxes  
Hollow shaft gearboxes  
Hydraulic motors

Nominal sizes

140 - 1.000 mm

Nominal torques

20 - 10.000 kNm

Pressure range

up to 180 bar

Versions

Hydraulic on the front  
Bolting on both sides

Features

simple design

Options

improved corrosion protection



# SHS Test Bench

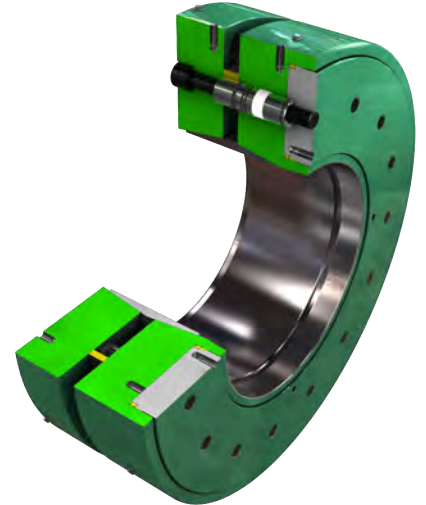
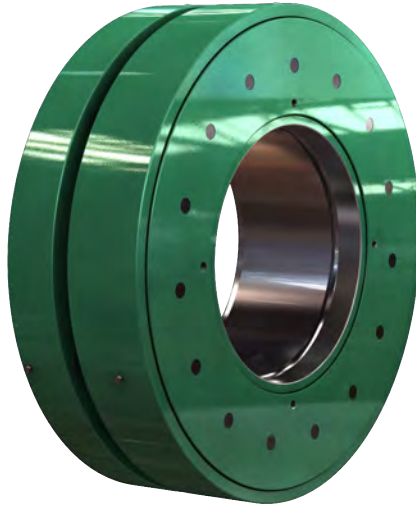

**SHS-530.2/2,5 P**

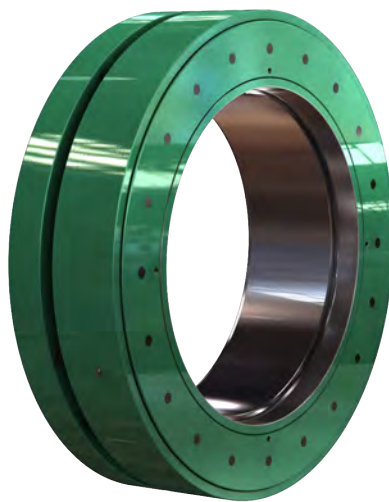

**SHS-1000/990 P**

Typical fields of application	Gearbox test stands
Nominal sizes	140 - 1.000 mm
Nominal torques	20 - 14.000 kNm
Pressure range	up to 200 bar (up to 400 bar for dismounting)
Versions	Hydraulic on the front or on the back Bolting on both sides or on the front
Features	Optimized for permanent operation reduced wear higher safety simplified handling and maintenance
Options	Application specific customization improved corrosion protection

## SHS Marine (with class approvals)



Typical fields of application	shafting
Nominal sizes	140 - 800 mm
Nominal torques	14 - 2.800 kNm
Pressure range	up to 200 bar
Versions	up to 400 bar (dismounting) Hydraulic on the front Hydraulic on the back Bolting on both sides
Features	Bolting on the front wide design reduced surface pressure high safety Application specific customization full class approvals
Options	hydraulic dismounting

## SHS Wind energy

### SHS-230 LR



Typical fields of application	Main rotor shaft
Nominal sizes	Generator shaft
Nominal torques	140 - 1.000 mm
Pressure range	20 - 12.000 kNm up to 200 bar
Versions	Hydraulic on the front Hydraulic on the back Bolting on both sides Bolting on the front
Features	special corrosion protection Application specific customization
Options	-

### SHS-530/2,5



# SHS Customized

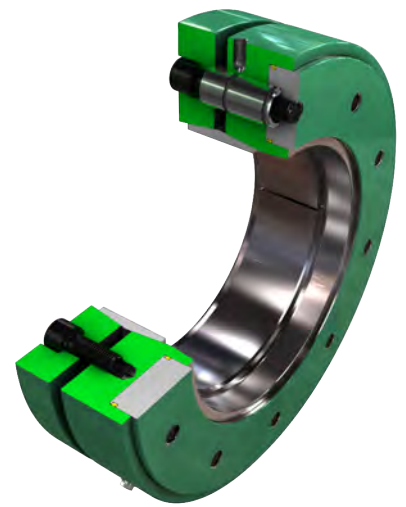

**SHS-300.2 P**

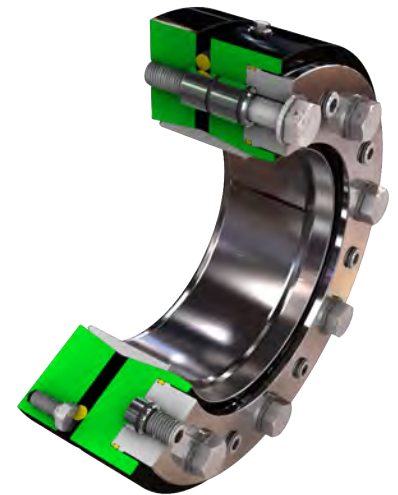

**SHS-240.1 MD DT**

Typical fields of application	Crusher Mills Shredder ... etc.
Nominal sizes	100 - 1.000 mm
Nominal torques	10 - 12.000 kNm
Pressure range	up to 200 bar up to 400 bar (dismounting)
Versions	Hydraulic on the front or on the back Bolting on both sides or on the front
Features	Application specific customization
Options	By arrangement and engineering viability

# Description of function FKH

## Rigid flange couplings of the type FKH

The main function of a hydraulic flange coupling (hereinafter called FKH) is the safe connection of two shafts. For example, between a drive shaft and a transmission shaft. The FKH produces a rigid and backlash-free connection between the shafts. This connection is mainly used to transmit torque, but can also absorb bending moments. The FKH is located in the power flow.

It is installed by sliding the FKH onto the shaft and the subsequent tightening of the hydraulic system. By using conical surfaces the inner diameter reduces and the radial pressure is built up. After clamping the FKH will be locked mechanically and the hydraulic pressure will be removed. Due to this simple approach, the FKH is suitable for repetitive clamping operations.

To achieve proper operation and to a sufficiently high coefficient of friction, the contact surfaces between shaft and FKH must be free of grease, dry and clean. The functional surfaces of the FKH are equipped at the factory with lubricant.

### Product data

#### Data sheets and CAD data:

- Our hydraulically actuated shrink discs are selected according to customer specifications or been redesigned.
- For this purpose please send us an e-mail to [info@tas-schaefer.de](mailto:info@tas-schaefer.de)

You can find the questionnaire for this product on:

[www.tas-schaefer.de](http://www.tas-schaefer.de)

### Advantages of the FKH

- high transmittable torque and bending moments (high friction)
- application-specific design/customization
- easy mounting and adjustment because of clearance fit
- relatively low pressure (closed system)
- very rapid tightening/loosening
- simple design (single cone)
- short installation length
- also usable for shafts with keyway (should be filled)
- combination of different shaft diameters

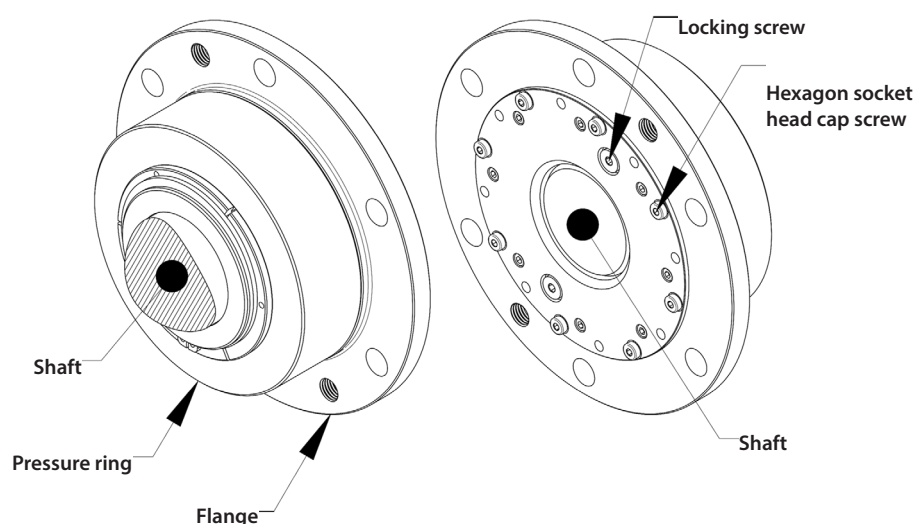

# FKH Rigid flange coupling

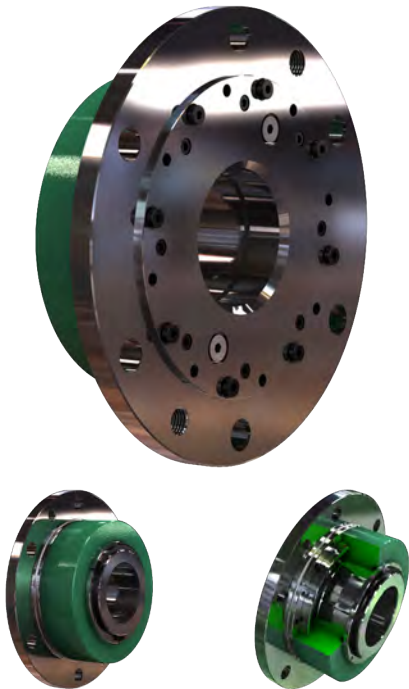

Typical fields of application	Conveyor drives
Nominal sizes	Agitator shaft
Nominal torques	70 - 500 mm
Pressure range	6 - 2.500 kNm
	up to 400 bar
Versions	standard design heavy design
Features	short installation length high stability tensionable from the shaft side desired shaft stepping closed hydraulic system mechanical lock
Options	improved corrosion protection

**FKH - 090P**





**TAS**  
**SCHÄFER**



## Shrink Discs 2-part

Torque-controlled | External clamping devices





# Description of function

## Two part shrink disc of the types TAS 31..

The main function of a shrink disc is the safe connection of a shaft with a hub by means of friction. For example, between a drive shaft and a transmission hollow shaft. The shrink disc generates a backlash-free connection by pressing the hub onto the shaft. This connection is mainly used to transmit torque.

The shrink disc only provides the required forces, and transfers no forces or moments between shaft and hub by itself. Therefore, the force flow does not pass through it.

It is installed by sliding the shrink disc onto the hollow shaft and the subsequent tightening of the screws. By using conical surfaces the inner diameter reduces and the radial pressure is built up. The 31xx range of shrink discs are self-locking. The clamping forces are provided and controlled through the screws (force controlled). This allows the direct compensation of the clearance between the shaft and hub, without an overload that may occur on path controlled shrink discs, due to small or over sized clearance. Except

for this are the shrink disks of the type 3173 as well as the types 3191 and 3193 to d 185mm. They are controlled by path (front faces are flush).

The supplied shrink discs are ready for installation.

To achieve proper operation with a sufficiently high coefficient of friction, the contact surfaces between shaft and hub must be dry, clean and free of grease. The functional surfaces of the shrink disc, the thread and head rests of the screws, are equipped at the factory with lubricant. Molykote G-Rapid Plus or comparable must be used as a lubricant. The contact surfaces between the hub and the bush must be provided with grease or oil before installation.

### Product data

A detailed installation manual is available on our Homepage.

Data sheets  
Contact us if a data sheet for an individual product is required.

Desired product is not available, please contact us directly.

CAD data  
We provide CAD data for our products in various formats. Please contact:

**Rolf Gertner**  
rolf.gertner@tas-schaefer.de

or

**Mike Kemper**  
mike.kemper@tas-schaefer.de

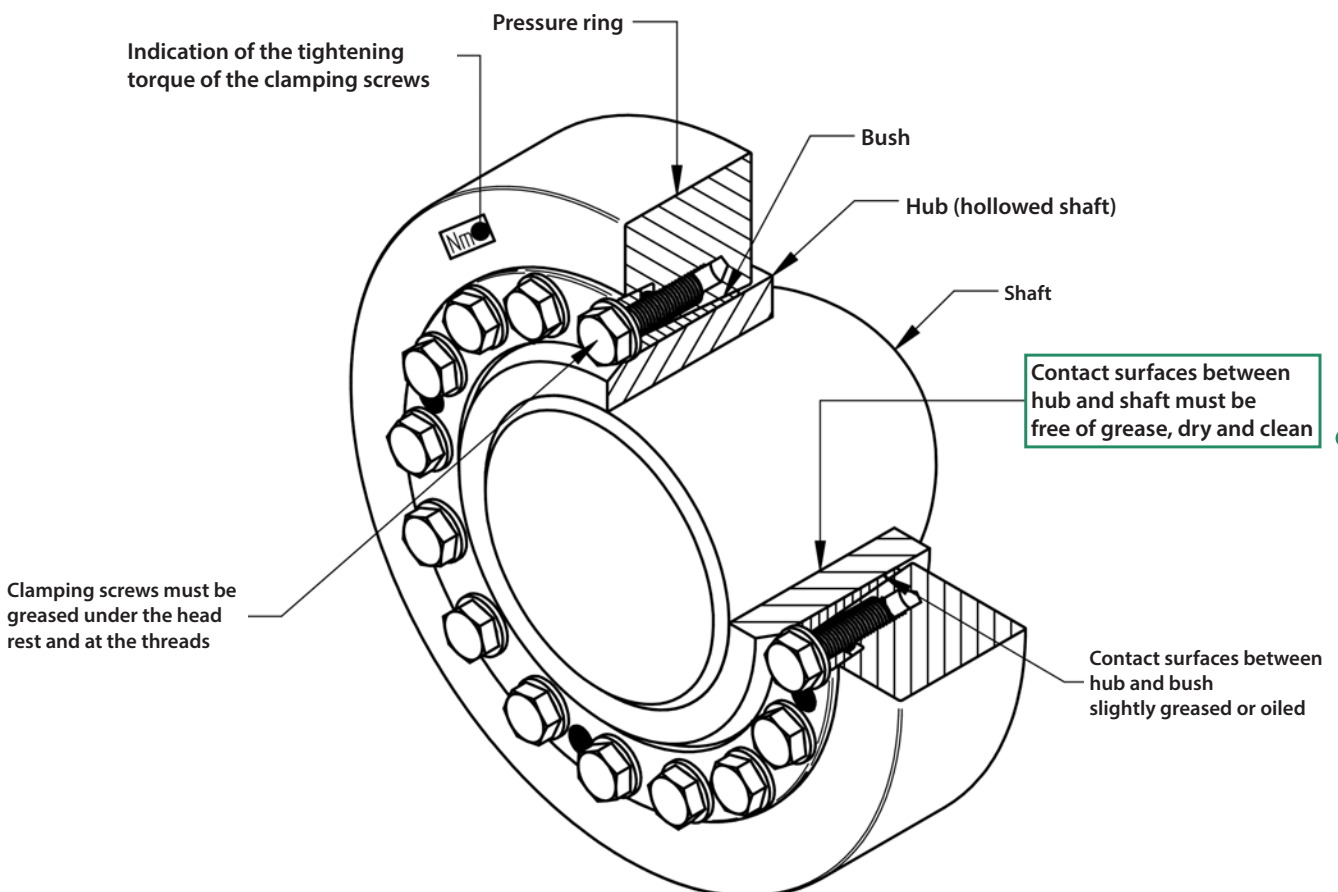



# Basics - Design

## Clamping length for shrink discs

The clamping length  $l$  of the shrink disk at the junction  $l_k$  (between shaft and hub), should be chosen to be somewhat wider to minimize the stress concentration at this point. An excessively wide connection increases the tendency to fretting corrosion, because the pressure decreases outward. The pressure is distributed approximately at an angle between  $15^\circ - 20^\circ$  through the hub. This is largely dependent on the hub wall thickness and stiffness of the shaft. A good approximation can be made from the following equation:

Clamping length of the contact area:  
 $l_k = 0,316(d - d_w) + l$

The cylindrical surfaces should be located symmetrically under the shrink disc! With a slightly different clamping length the transmissible torque  $M$  will not change, because a smaller contact surface results in a higher pressure - ergo a larger contact surface causes lower pressure.

## Tightening torque of the clamping screws

The given tightening torque values in the tables for the screws are based on a friction coefficient  $\mu_{ges} = 0,1$ . In principle, the specified tightening torque  $M_A$  can be reduced to  $M_{Agew}$  to reduce stresses in the components. This may be necessary for soft materials and bored shafts. The reduction of  $M_A$  also reduced the pressure  $p_N$  and transmissible torque  $M$ . The ratio is approximately proportional and can be calculated according to:

$$M = \frac{M_{Agew}}{M_A} M \quad \text{also} \quad p_N = \frac{M_{Agew}}{M_A} p_N$$

The tightening torques can not be reduced arbitrary, therefore apply the following limits:

$$M_{Agew} \geq \begin{matrix} \text{Class 8.8 : } 0,85 M_A \\ \text{Class 10.9 : } 0,70 M_A \\ \text{Class 12.9 : } 0,60 M_A \end{matrix} \leq M_A$$

A further reduction requires additional screw locks!

The values found in the product data based on surface quality and tolerances according to the table below. These values are given as recommendations.

Higher values for the surface roughness reduces the transmissible torque and promote unwanted settling. Larger clearance also reduces the transmissible torque and heightened tensions in the hub.

**In the case of significantly different values, please contact us!**

**Tolerance for the outer diameter hub - f7!**

Recommended tolerances and surface roughness

>	≤	FS <sub>max</sub> mm	Clearance Hub/Shaft	Rz µm
9	18	0,022	H6/h6	10
18	30	0,026	H6/h6	10
30	50	0,032	H6/h6	10
50	80	0,049	H7/h6	10
80	120	0,057	H7/h6	16
120	150	0,065	H7/h6	16
150	180	0,079	H7/g6	16
180	250	0,090	H7/g6	16
250	315	0,101	H7/g6	16
315	400	0,111	H7/g6	16
400	500	0,123	H7/g6	25
500	630	0,136	H7/g6	25
630	800	0,154	H7/g6	25
800	1000	0,172	H7/g6	25

# Basics - Calculation

The calculation of the values, given in the catalogue, are based on the following assumptions and simplifications:

## Transmissible torque

A shrink disc connection is capable of transmitting torque, bending moment and axial force. Alternatively, the transmissible torque  $M_{\max}$  is specified in the product data. If such loads occur simultaneously then they must be added vectorially to the resultant moment  $M_{\text{res}}$ .

The formula below applies to the resulting moment:

$$M_{\text{res}} \leq M_{\max}$$

At different load cases, these are individually checked against  $M_{\max}$ !  $M_{\text{res}}$  is determined for combined loads as follows:

$$M_{\text{res}} = \sqrt{M_T^2 + 2M_B^2 + (F_{\text{AX}} \frac{d_W}{2})^2}$$

$$\text{with } M_B \leq 0,3 M_{\max}$$

as the limit\* for the the bending moment

\*In principle, the maximum bending moment corresponds to the maximum transmittable torque. The limitation to 0,3  $M_{\max}$  is due to the change of the surface pressure at the edges of the connection. (see also „Bending moment“)

This results in the following relationships:

### Torque only:

The maximum torque is equivalent to  $M_{\max}$

### Bending moment only:

The maximum bending moment corresponds to 0,3  $M_{\max}$ .

### Axial force only:

The maximum axial force is

$$M_{\max} \frac{2}{d_W}$$

A different equation applies for very small shrink discs (3073):

$$M_B \leq 0,2 M_{\max}$$

Depending on the application, additional safety factors need to be considered for the individual loads!

## Calculation of transmissible torques and forces

The catalogue data relates to specific shaft diameters which we recommend using. If the shaft diameter is between two sizes, the larger shrink disc should be selected. A deviation is possible within certain limits but the predetermined tolerances and surface roughness should be considered.

The shaft diameter and transmissible torque behave approximately proportional to each other. The transmissible torque increases with greater shaft diameter and vice versa. In contrast, the transmissible axial force changes only slightly. This is not due to the shaft diameter but because of the change in stiffness of the hub when the inner diameter changes.

Within certain limits, the changes can be linearly approximated. Information about the range of the respective shaft diameter can be found in the product data. The determination of the deviating values is explained below. Please contact us if the shaft diameter must be outside the indicated range. The formula below calculates the torque for specific shaft diameters:

$$M = M_{\max(\text{Catalog})} \left( \frac{d_W(\text{target})}{d_W(\text{Catalog})} \right)^2$$

The corresponding axial force which is transmitted instead of the torque, results as follows:

$$F_{\text{ax}} = M \frac{2}{d_W(\text{table})}$$

## Radial force

Radial forces cause a change in pressure at the contact surface. In the force direction, the pressure increases on the one side and is reduced accordingly on the other side. This depends on the amount of radial force and the rigidity of the parts.

The following equation can be used to approximate the pressure change:

$$\Delta p_W = 0,75 \frac{F_{\text{AX}}}{d_W l_K}$$

The modified pressures  $p_{W_{\min, \max}}$  results from the following equation:

$$p_{W_{\min, \max}} = p_W \pm \Delta p_W$$

The minimum pressure  $p_{W_{\min}}$  should be at least 50 N/mm<sup>2</sup> to avoid gap corrosion. In addition, the material must be designed for a maximum pressure  $p_{W_{\max}}$ .



# Basics - Calculation

The calculation of the values, given in the catalogue, are based on the following assumptions and simplifications:

## Bending moment

Here the situation is similar to the radial forces. However the pressure is greatest at the ends of the connection in this case. Again, the amount and stiffness are important. This leads to the following approximation:

$$\Delta p_W = 4,5 \frac{M_B}{d_W l_K^2}$$

As before, the modified pressures results from:

$$p_{Wmin, max} = p_W \pm \Delta p_W$$

The conditions for minimum and maximum pressure are the same as before. It should be noted that there could be a change in pressure due to radial force!

The information on the minimum yield strength of shafts and hubs are suggested recommendations, based on typical values for such applications. They are provided as guidelines and are not a replacement for a proper calculation for a given application!

## Notch effect

Generally there is a notch effect on the components, caused by the radial pressure of the shrink disc. This depends mainly on the applied pressure. The notch effect is generally higher on the hub than on the shaft, because here the inner ring of the shrink disc is directly pressed onto the hub, while the stresses are distributed through the hub before reaching the shaft. The notch factors range from 2,5 to 3,5 for the hub and it is between 1,5 and 2 for the shaft. This can be mitigated by suitable design features, such as relief notches.

Some standards provide the possibility of a notch factor to be determined by a fit pairing for a shrink-connection. A similar method also can be used for a shrink disc connection. To this end an oversize can be calculated from the applied surface pressures. As a result, a matching fit pair can be determine and thus a resultant notch factor found.

## Bore in the shaft (hollow shaft)

A large bore  $d_B$  in the shaft or the use of a hollow shaft, reduces the stiffness of this component against radial pressure. This leads to a decrease in pressure  $p_W$ , a reduced transmissible torque  $M$ , a contraction  $\Delta B$  within the shaft and an increase of stresses in these components. Basically, a bore should not be greater than 0,3  $d_W$ .

## Shaft and hub calculation

The catalogue contains information on the generated surface pressure for each shrink disc. The hub will be deformed due to the applied radial force. In addition to the clearance between shaft and hub, shaft stiffness and surface finish should be considered. For solid shafts the flexibility can be ignored, but with hollow shafts (see „Bore in the shaft (hollow shaft)“) there is greater deformation and thus greater stresses in the components. This must be considered in addition to other loads.

The stresses in the hub can be determined by various hypotheses, such as GEH. We will not make a presentation and analyse results at this point because we would only be able to cover a very limited range of static applications. Various calculation methods for different cases can be found in engineering literature or using specialised software. However, for complex geometry often only a calculation by FEM gives reliable results.

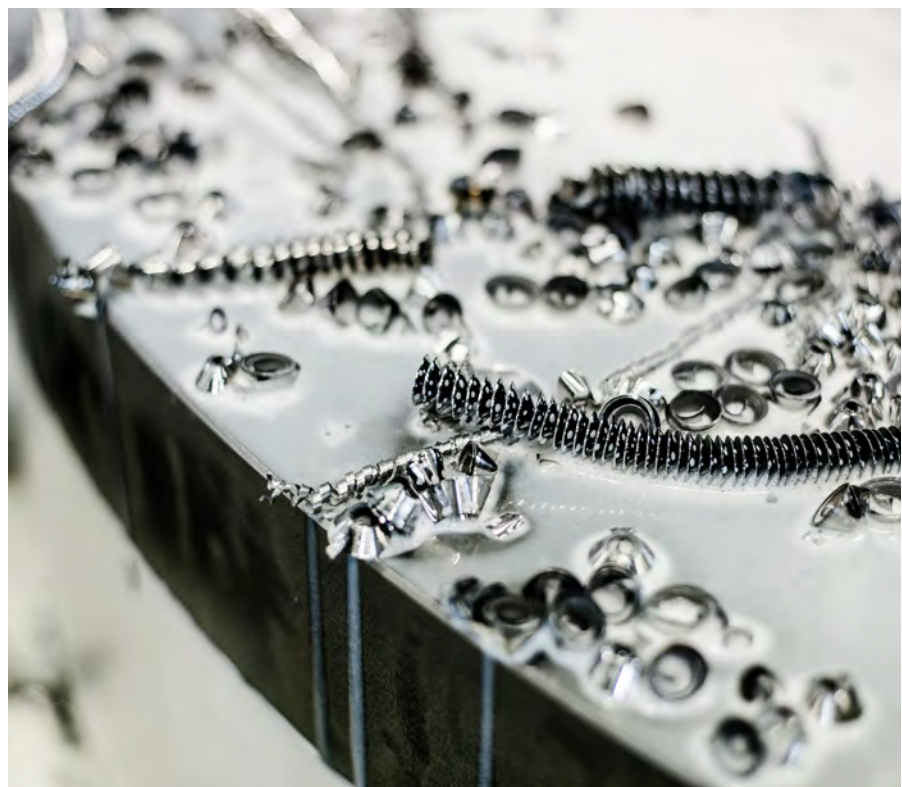





**TAS**  
**SCHÄFER**



# 3171 Standard-Range

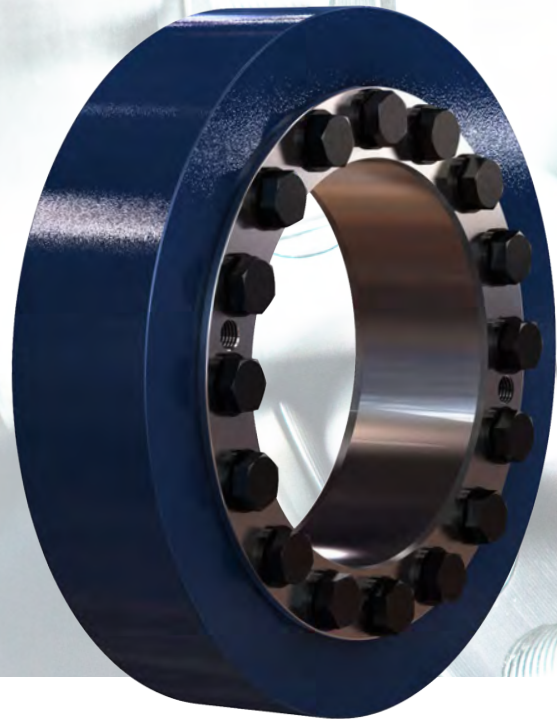
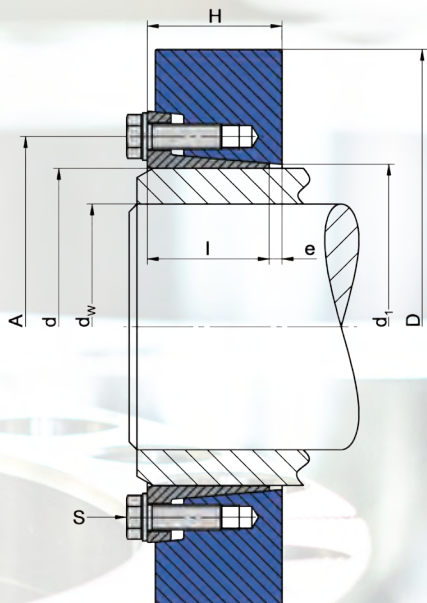

## Used symbols

d	[mm]	Nominal diameter of the shrink disc
$d_w$	[mm]	Shaft diameter
$M_{max}$	[mm]	Maximal transmittable torque
D	[mm]	Outer diameter
l	[mm]	Length of the bush
e	[mm]	Excess length
H	[mm]	Width of the shrink disc
A	[mm]	Pitch circle diameter
$d_1$	[mm]	Attachment size
$M_A$	[Nm]	Tightening torque of the clamping screws
Z		Number of clamping screws
S		Size of the clamping screws
$n_{max}$	[min <sup>-1</sup> ]	Permitted rotational frequency
$p_N$	[N/mm <sup>2</sup> ]	Average Pressure to the hub
I	[kgm <sup>2</sup> ]	Moment of inertia

## Design of the shrink disc

$d < 120$	Discs lightly oiled without washers
$d \geq 120$	Discs painted with washers
$d \geq 195$	Cone of bush not slit

Dimensions H & e in unlocked position

min. yield strength Rp0,2	N/mm <sup>2</sup>
Solid shaft	290
hub	350

## Variation from the standard shaft diameter $d_w$

> mm	≤ mm	minimal - mm	maximal + mm
10	30	-1	1
30	50	-3	2
50	140	-5	5
140	180	-10	5
180	320	-15	10
320	500	-20	10
500	700	-30	20

$$M = M_{max(Catalog)} \left( \frac{d_w(target)}{d_w(Catalog)} \right)^2$$

(see Basics - Calculation)

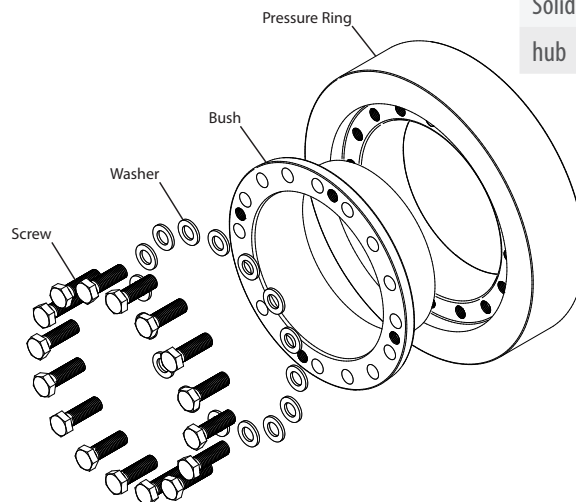

Ordering information: TAS 3171-d (z.B.: TAS 3171-200 ... further sizes on request)

# 3171 Standard-Range

<b>d</b> mm	<b>d<sub>w</sub></b> mm	<b>M<sub>max</sub></b> Nm	<b>D</b> mm	<b>l</b> mm	<b>e</b> mm	<b>H</b> mm	<b>A</b> mm	<b>d<sub>1</sub></b> mm	<b>M<sub>A</sub></b> Nm	<b>Z</b> Stk	<b>S</b>	<b>DIN</b>	<b>Class</b>	<b>n<sub>max</sub></b> min <sup>-1</sup>	<b>p<sub>N</sub></b> N/mm <sup>2</sup>	<b>I</b> kgm <sup>2</sup>	<b>Weight</b> kg
14	11	36	38	10	1	11	26	15	12	3	M 6 x 10	933	10.9	15078	386	0,0000154	0,08
16	13	75	41	13,5	1,5	15	28	17	12	3	M 6 x 12	933	10.9	13975	431	0,0000285	0,12
18	15	100	44	13,5	1,5	15	30	19	12	3	M 6 x 12	933	10.9	13022	389	0,0000376	0,13
20	17	150	47	13,5	1,5	15	32	22	12	3	M 6 x 12	933	10.9	12191	342	0,0000488	0,15
24	20	215	50	16	2	18	36	26	12	4	M 6 x 16	933	10.9	11459	329	0,0000734	0,19
30	25	430	60	18	2	20	44	32	12	6	M 6 x 16	933	10.9	9549	341	0,0001689	0,30
36	30	740	72	20	2	22	52	38	30	5	M 8 x 20	933	10.9	7958	483	0,0003786	0,47
38	32	760	72	20	2	22	53	40	30	5	M 8 x 20	933	10.9	7958	460	0,0003725	0,45
44	35	790	80	22	2	24	61	47	30	5	M 8 x 20	933	10.9	7162	341	0,0006151	0,59
50	40	1370	90	23,5	2,5	26	68	53	30	7	M 8 x 20	933	10.9	6366	386	0,0010705	0,81
55	45	1840	100	26	3	29	72	58	30	8	M 8 x 20	933	10.9	5730	360	0,0018431	1,13
62	50	1990	110	26	3	29	80	66	30	8	M 8 x 20	933	10.9	5209	318	0,0026706	1,34
68	55	2460	115	26	3	29	86	72	30	9	M 8 x 20	933	10.9	4982	329	0,0031146	1,40
75	60	3830	138	27	4	31	100	79	59	8	M 10 x 25	933	10.9	4152	424	0,0070393	2,28
80	65	4240	138	27	4	31	104	84	59	8	M 10 x 25	933	10.9	4152	399	0,0068412	2,15
85	68	6000	155	34	4	38	114	94	59	10	M 10 x 30	933	10.9	3697	338	0,0138071	3,53
90	70	5830	155	34	4	38	114	94	59	10	M 10 x 30	933	10.9	3697	338	0,0134544	3,35
100	75	7400	170	39	4	43	124	104	59	12	M 10 x 30	933	10.9	3370	305	0,0220976	4,54
105	80	10000	185	44	5	49	136	114	100	10	M 12 x 30	933	10.9	3097	308	0,0362860	6,42
110	85	11700	185	44	5	49	136	114	100	10	M 12 x 30	933	10.9	3097	308	0,0354267	6,12
125	95	14900	215	47,5	5,5	53	160	134	100	12	M 12 x 35	933	10.9	2665	284	0,0703948	9,11
130	100	19600	215	47,5	5,5	53	160	134	100	12	M 12 x 35	933	10.9	2665	284	0,0688524	8,73
135	100	20400	230	52	6	58	173	145	160	10	M 14 x 40	933	10.9	2491	284	0,1009972	11,4
140	105	19000	230	52	6	58	173	145	160	10	M 14 x 40	933	10.9	2491	284	0,0988674	10,9
150	110	26400	263	56	6	62	190	164	160	12	M 14 x 40	933	10.9	2179	274	0,1864460	16,3
155	115	27200	263	56	6	62	190	164	160	12	M 14 x 40	933	10.9	2179	274	0,1833539	15,7
160	120	32000	263	56	6	62	190	164	160	12	M 14 x 40	933	10.9	2179	274	0,1799476	15,2
165	125	38200	290	61	7	68	204	175	250	10	M 16 x 45	933	10.9	1976	297	0,3044866	21,9
175	135	46000	300	60	8	68	214	185	250	12	M 16 x 50	933	10.9	1910	345	0,3444253	22,8
185	145	66700	330	77	8	85	226	194	250	14	M 16 x 50	933	10.9	1736	278	0,6464885	36,1
195	150	82000	350	77	8	85	240	205	250	16	M 16 x 50	933	10.9	1637	300	0,8151453	40,6
200	155	83600	350	77	8	85	240	205	250	16	M 16 x 50	933	10.9	1637	300	0,8058820	39,7
220	165	109000	370	94	10	104	270	226	490	16	M 20 x 60	933	10.9	1549	342	1,2075884	52,1
240	180	140000	405	97	10	107	296	246	490	18	M 20 x 60	933	10.9	1415	342	1,8077432	65,3
260	200	184000	430	109	10	119	318	266	490	21	M 20 x 60	933	10.9	1332	319	2,5259772	80,0
280	220	240000	460	124	10	134	340	287	490	22	M 20 x 60	933	10.9	1246	269	3,6716977	101
300	230	300000	485	132	10	142	360	307	840	20	M 24 x 70	933	10.9	1181	323	4,7555885	117
320	250	332000	520	133	10	143	380	327	840	21	M 24 x 70	933	10.9	1102	319	6,2826175	135
340	260	427000	570	146	12	158	402	348	840	22	M 24 x 80	931	10.9	1005	278	10,2530016	186
360	280	539000	590	150	12	162	424	368	840	24	M 24 x 80	931	10.9	971	278	11,9213225	200
380	290	536000	635	149	14	163	448	388	1250	18	M 27 x 80	933	10.9	902	258	16,5612857	242
390	300	561000	650	152	14	166	458	398	1250	18	M 27 x 80	933	10.9	881	252	18,1541897	253

# 3171 Standard-Range

$d$ mm	$d_w$ mm	$M_{max}$ Nm	$D$ mm	$l$ mm	$e$ mm	$H$ mm	$A$ mm	$d_1$ mm	$M_A$ Nm	$Z$ Stk	$S$	$DIN$	$Class$	$n_{max}$ min <sup>-1</sup>	$p_N$ N/mm <sup>2</sup>	$I$ kgm <sup>2</sup>	$Weight$ kg
400	310	648000	660	158	15	173	475	410	1250	20	M 27 x 80	931	10.9	868	255	20,3512933	273
420	330	731300	690	171	15	186	495	430	1250	21	M 27 x 80	931	10.9	830	236	25,7145823	315
440	350	912000	740	181	15	196	516	448	1250	24	M 27 x 80	931	10.9	774	243	36,3755200	393
460	370	1026000	770	181	15	196	536	468	1250	25	M 27 x 80	933	10.9	744	243	42,5268672	423
480	390	1177000	800	201	15	216	556	488	1250	27	M 27 x 80	933	10.9	716	223	54,3812311	500
500	410	1288000	850	201	15	216	580	510	1250	28	M 27 x 80	933	10.9	674	222	70,0908985	577
530	440	1660000	910	223	15	238	616	538	1700	27	M 30 x 90	931	10.9	630	219	102,5969192	740
560	460	2083000	940	223	22	245	646	568	1700	28	M 30 x 90	931	10.9	610	250	115,3714200	771
590	480	2140000	950	240	23	263	670	598	1700	28	M 30 x 100	931	10.9	597	219	126,5966100	810
620	510	2560000	970	268	23	291	716	630	1700	28	M 30 x 100	931	10.9	562	206	149,6295300	904
640	530	2372000	970	269	18	287	736	650	1700	28	M 30 x 100	931	10.9	562	178	145,5701500	862
660	550	2830000	1020	270	22	292	770	670	2200	28	M 33 x 110	931	10.9	535	195	182,4488800	989





# TAS SCHÄFER

# FRICITION SPRING RELIABILITY MAKES THE DIFFERENCE

- High spring energy with low weight and volume
- High damping
- Overload secure in block setting
- Independent of the loading rate
- Maintenance - free
- Variable construction of the friction spring



**TAS Schäfer GmbH**

Osterfeldstrasse 75  
58300 Wetter

Telefon: +49 (0) 2335 9781-0

Fax: +49 (0) 2335 72956

[www.tas-schaefer.de](http://www.tas-schaefer.de)  
[info@tas-schaefer.de](mailto:info@tas-schaefer.de)





# 3181 Standard-Range (strengthened)

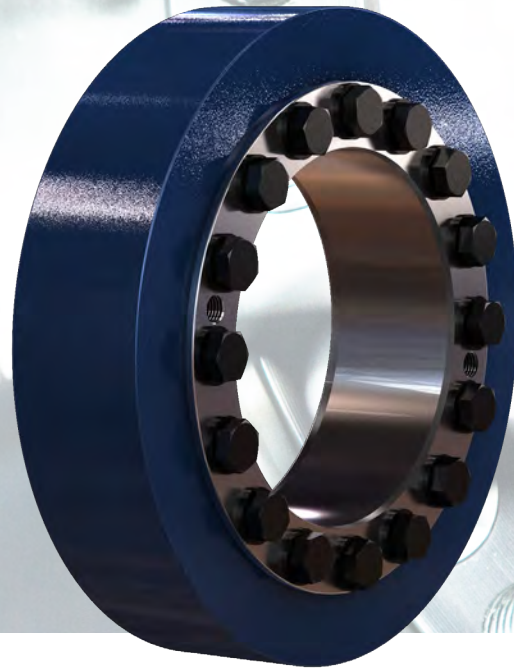
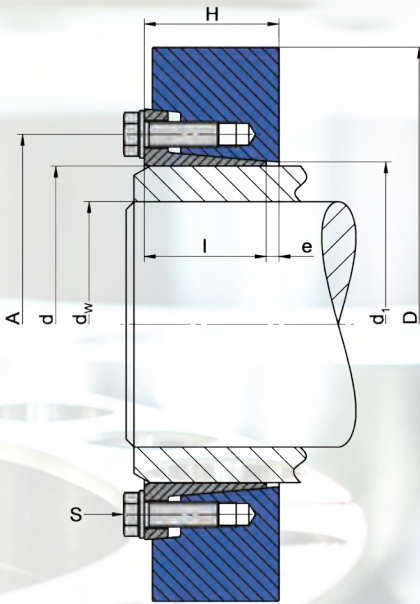

## Used symbols

d	[mm]	Nominal diameter of the shrink disc
d <sub>w</sub>	[mm]	Shaft diameter
M <sub>max</sub>	[mm]	Maximal transmittable torque
D	[mm]	Outer diameter
l	[mm]	Length of the bush
e	[mm]	Excess length
H	[mm]	Width of the shrink disc
A	[mm]	Pitch circle diameter
d <sub>1</sub>	[mm]	Attachment size
M <sub>A</sub>	[Nm]	Tightening torque of the clamping screws
Z		Number of clamping screws
S		Size of the clamping screws
n <sub>max</sub>	[min-1]	Permitted rotational frequency
p <sub>N</sub>	[N/mm <sup>2</sup> ]	Average pressure to the hub
I	[kgm <sup>2</sup> ]	Moment of inertia

## Design of the shrink disc

d < 120	Discs lightly oiled without washers
d ≥ 120	Discs painted with washers
d ≥ 195	Cone of bush not slit

Dimensions H & e in unlocked position

min. yield strength Rp0,2	N/mm <sup>2</sup>
Solid shaft	350
Hub	450

## Variation from the standard shaft diameter d<sub>w</sub>

> mm	≤ mm	minimal - mm	maximal + mm
10	30	-1	1
30	50	-3	2
50	140	-5	5
140	180	-10	5
180	320	-15	10
320	500	-20	10
500	700	-30	20

$$M = M_{\max(\text{Catalog})} \left( \frac{d_{w(\text{target})}}{d_{w(\text{Catalog})}} \right)^2$$

(see Basics - Calculation)

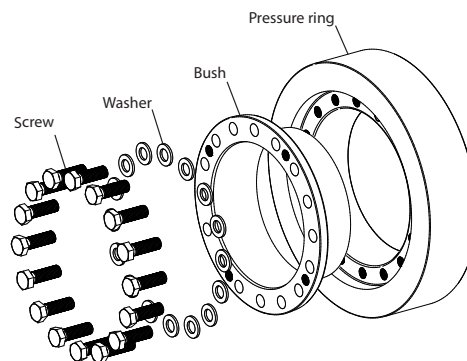

Ordering information: TAS 3181 - d (z.B.: TAS 3181-200 ... further sizes on request)

# 3181 Standard-Range (strengthened)

<b>d</b> mm	<b>d<sub>w</sub></b> mm	<b>M<sub>max</sub></b> Nm	<b>D</b> mm	<b>l</b> mm	<b>e</b> mm	<b>H</b> mm	<b>A</b> mm	<b>d<sub>1</sub></b> mm	<b>M<sub>A</sub></b> Nm	<b>Z</b> Stk	<b>S</b>	<b>DIN</b>	<b>Klasse</b>	<b>n<sub>max</sub></b> min <sup>-1</sup>	<b>p<sub>N</sub></b> N/mm <sup>2</sup>	<b>I</b> kgm <sup>2</sup>	<b>Weight</b> kg
24	20	275	50	16	2	18	36	26	14	4	M 6 x 16	933	12.9	11459	387	0,0000734	0,19
30	25	570	60	18	2	20	44	32	14	6	M 6 x 16	933	12.9	9549	400	0,0001689	0,30
36	30	880	72	20	2	22	52	38	35	5	M 8 x 20	933	12.9	7958	564	0,0003786	0,47
38	32	910	72	20	2	22	53	40	35	5	M 8 x 20	933	12.9	7958	536	0,0003725	0,45
44	35	960	80	22	2	24	61	47	35	5	M 8 x 20	933	12.9	7162	398	0,0006151	0,59
50	40	1700	90	23,5	2,5	26	68	53	35	7	M 8 x 20	933	12.9	6366	451	0,0010705	0,81
55	45	2000	99,3	26	3	29	72	58	35	6	M 8 x 20	933	12.9	5770	316	0,0017869	1,11
62	50	2400	110	26	3	29	80	66	35	8	M 8 x 20	933	12.9	5209	371	0,0026706	1,34
68	55	3000	115	26	3	29	86	72	35	9	M 8 x 20	933	12.9	4982	384	0,0031146	1,40
75	60	4600	138	27	4	31	100	79	69	8	M 10 x 25	933	12.9	4152	496	0,0070393	2,28
80	65	5200	138	27	4	31	104	84	69	8	M 10 x 25	933	12.9	4152	467	0,0068412	2,15
85	68	6700	155	34	4	38	114	94	69	10	M 10 x 30	933	12.9	3697	396	0,0138071	3,53
90	70	7100	155	34	4	38	114	94	69	10	M 10 x 30	933	12.9	3697	396	0,0134544	3,35
100	75	8800	170	39	4	43	124	104	69	12	M 10 x 30	933	12.9	3370	357	0,0220976	4,54
105	80	12600	185	44	5	49	136	114	120	10	M 12 x 30	933	12.9	3097	360	0,0362860	6,42
110	85	14600	185	44	5	49	136	114	120	10	M 12 x 30	933	12.9	3097	360	0,0354267	6,12
125	95	18700	215	47,5	5,5	53	160	134	120	12	M 12 x 35	933	12.9	2665	333	0,0703948	9,11
130	100	22900	215	47,5	5,5	53	160	134	120	12	M 12 x 35	933	12.9	2665	333	0,0688524	8,73
135	100	23400	230	52	6	58	173	145	190	10	M 14 x 40	933	12.9	2491	334	0,1009972	11,4
140	105	23500	230	52	6	58	173	145	190	10	M 14 x 40	933	12.9	2491	334	0,0988674	10,9
150	110	31300	263	56	6	62	190	164	190	12	M 14 x 40	933	12.9	2179	321	0,1864460	16,3
155	115	34200	263	56	6	62	190	164	190	12	M 14 x 40	933	12.9	2179	321	0,1833539	15,7
160	120	38300	263	56	6	62	190	164	190	12	M 14 x 40	933	12.9	2179	321	0,1799476	15,2
165	125	48300	290	61	7	68	204	175	290	10	M 16 x 45	933	12.9	1976	349	0,3044866	21,9
175	135	58200	300	60	8	68	214	185	290	12	M 16 x 50	933	12.9	1910	405	0,3444253	22,8
185	145	82000	330	77	8	85	224	194	290	14	M 16 x 50	933	12.9	1736	326	0,6464885	36,1
195	150	98200	350	77	8	85	240	205	290	16	M 16 x 50	933	12.9	1637	353	0,8151453	40,6
200	155	102000	350	77	8	85	240	205	290	16	M 16 x 50	933	12.9	1637	353	0,8058820	39,7
220	165	134000	370	94	10	104	270	226	570	16	M 20 x 60	933	12.9	1549	401	1,2075884	52,1
240	180	172000	405	97	10	107	296	246	570	18	M 20 x 60	933	12.9	1415	400	1,8077432	65,3
260	200	226000	430	109	10	119	318	266	570	21	M 20 x 60	933	12.9	1332	373	2,5259772	80,0
280	220	295000	460	124	10	134	340	287	570	22	M 20 x 60	933	12.9	1246	315	3,6716977	101
300	230	367000	485	132	10	142	360	307	980	20	M 24 x 70	933	12.9	1181	379	4,7555885	117
320	250	410000	520	133	10	143	380	327	980	21	M 24 x 70	933	12.9	1102	374	6,2826175	135
340	260	525000	570	146	12	158	402	348	980	22	M 24 x 80	931	12.9	1005	327	10,2530016	186
360	280	553000	590	150	12	162	424	368	980	21	M 24 x 80	931	12.9	971	285	11,9213225	200
380	290	636000	635	149	14	163	448	388	1450	18	M 27 x 80	933	12.9	902	303	16,5612857	242
390	300	666700	650	152	14	166	458	398	1450	18	M 27 x 80	933	12.9	881	296	18,1541897	253
400	310	769000	660	158	15	173	475	410	1450	20	M 27 x 80	931	12.9	868	299	20,3512933	273
420	330	868000	690	171	15	186	495	430	1450	21	M 27 x 80	931	12.9	830	278	25,7145823	315
440	350	1081000	740	181	15	196	516	448	1450	24	M 27 x 80	931	12.9	774	285	36,3755200	393
460	370	1214000	770	181	15	196	536	468	1450	25	M 27 x 80	933	12.9	744	285	42,5268672	423
480	390	1393000	800	201	15	216	556	488	1450	27	M 27 x 80	933	12.9	716	262	54,3812311	500
500	410	1525000	850	201	15	216	580	510	1450	28	M 27 x 80	933	12.9	674	260	70,0908985	577



# 3181 Standard-Range (strengthened)

<b>d</b> mm	<b>d<sub>w</sub></b> mm	<b>M<sub>max</sub></b> Nm	<b>D</b> mm	<b>l</b> mm	<b>e</b> mm	<b>H</b> mm	<b>A</b> mm	<b>d<sub>1</sub></b> mm	<b>M<sub>A</sub></b> Nm	<b>Z</b> Stk	<b>S</b>	<b>DIN</b>	<b>Klasse</b>	<b>n<sub>max</sub></b> min <sup>-1</sup>	<b>p<sub>N</sub></b> N/mm <sup>2</sup>	<b>I</b> kgm <sup>2</sup>	<b>Weight</b> kg
<b>530</b>	440	1960000	910	226	15	241	616	538	1950	27	M 30 x 90	931	12.9	630	257	102,5969192	740
<b>560</b>	460	2457000	940	223	22	245	646	568	1950	28	M 30 x 90	931	12.9	610	293	152,4393500	771
<b>590</b>	480	2524000	950	240	23	263	670	598	1950	28	M 30 x 100	931	12.9	597	257	160,4661900	810
<b>620</b>	510	3018000	970	268	28	296	716	630	1950	28	M 30 x 100	931	12.9	562	241	189,6250362	903
<b>640</b>	530	2805000	1020	269	18	287	736	650	1950	28	M 30 x 100	931	12.9	562	208	185,5656631	1024
<b>660</b>	550	3356000	1070	270	22	292	770	670	2600	28	M 33 x 110	931	12.9	535	230	229,1223900	1160



**We stand for  
Quality in  
every field**

**TAS**  
**SCHÄFER**



# 3191 Heavy-Range

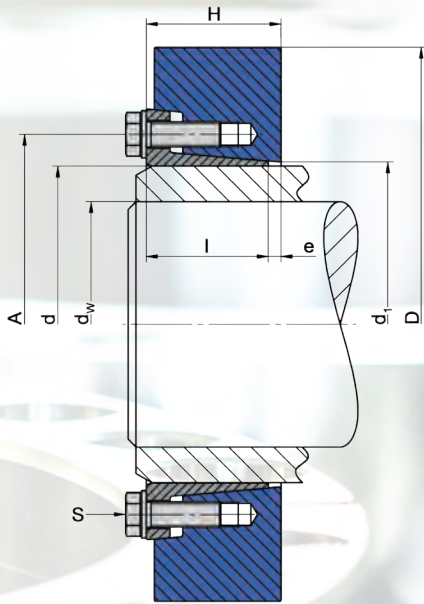

## Used Symbols

$d$	[mm]	Nominal diameter of the shrink disc
$d_w$	[mm]	Shaft diameter
$M_{max}$	[Nm]	Maximal transmittable torque
$D$	[mm]	Outer diameter
$l$	[mm]	Length of the bush
$e$	[mm]	Excess length
$H$	[mm]	Width of the shrink disc
$A$	[mm]	Pitch circle diameter
$d_1$	[mm]	Attachment size
$M_A$	[Nm]	Tightening torque of the clamping screws
$Z$		Number of clamping screws
$S$		Size of the clamping screws
$n_{max}$	[min <sup>-1</sup> ]	Permitted rotational frequency
$p_N$	[N/mm <sup>2</sup> ]	Average pressure to the hub
$I$	[kgm <sup>2</sup> ]	Moment of inertia

## Design of the shrink disc

$d < 120$	Discs lightly oiled without washers
$d \geq 120$	Disc painted with washers
$d \geq 195$	Cone of bush not slit

Dimensions H & e in unlocked position

min. yield strength Rp0,2	N/mm <sup>2</sup>
Solid shaft	290
Hub	350

## Variation from the standard shaft diameter $d_w$

> mm	≤ mm	minimal - mm	maximal + mm
40	50	-3	2
50	140	-5	5
140	180	-10	5
180	320	-15	10
320	440	-20	10
440	600	-30	10

$$M = M_{max (Catalog)} \left( \frac{d_w (target)}{d_w (Catalog)} \right)^2$$

(see Basics - Calculation)

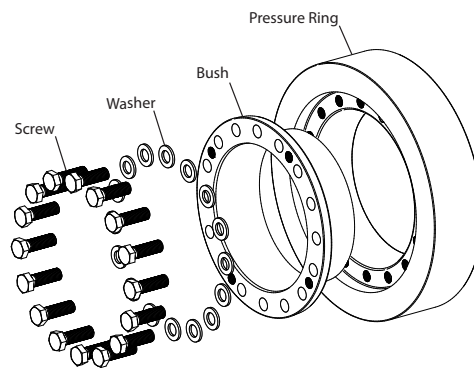

Ordering information: TAS 3191 - d (z.B.: TAS 3191-200 ... further sizes on request)



# 3191 Heavy-Range

<b>d</b> mm	<b>d<sub>w</sub></b> mm	<b>M<sub>max</sub></b> Nm	<b>D</b> mm	<b>l</b> mm	<b>e</b> mm	<b>H</b> mm	<b>A</b> mm	<b>d<sub>1</sub></b> mm	<b>M<sub>A</sub></b> Nm	<b>Z</b> Stk	<b>S</b>	<b>DIN</b>	<b>Class</b>	<b>n<sub>max</sub></b> min <sup>-1</sup>	<b>p<sub>N</sub></b> N/mm <sup>2</sup>	<b>I</b> kgm <sup>2</sup>	<b>Weight</b> kg
110	80	13413	185	65	5	70	139	113	100	10	M 12 x 35	933	12.9	3097	226	0,0508296	8,78
125	90	22621	215	69	6,5	75,5	163	129	250	8	M 16 x 50	933	12.9	2665	291	0,0959929	12,4
135	95	24251	230	69	6,5	75,5	178	144	250	8	M 16 x 50	933	12.9	2491	248	0,1250883	14,1
140	105	30603	230	69	6,5	75,5	178	144	250	8	M 16 x 50	933	12.9	2491	248	0,1278926	14,1
155	115	50510	263	72	9	81	196	159	250	12	M 16 x 50	933	12.9	2179	318	0,2402568	20,6
165	125	62853	290	81	8	89	204	169	250	12	M 16 x 50	933	12.9	1976	285	0,3853659	27,7
175	135	72733	300	81	8	89	214	179	250	12	M 16 x 50	933	12.9	1910	262	0,4359133	28,9
185	145	122608	320	100	12,5	112,5	232	189	480	12	M 20 x 60	933	12.9	1790	310	0,7859084	43,9
200	155	113000	350	102	11	113	246	204	490	14	M 20 x 60	933	10.9	1637	302	1,0778672	53,1
220	165	137000	370	127	9	136	270	225	490	18	M 20 x 60	933	10.9	1549	271	1,5895806	68,6
240	180	180000	405	132	12	144	298	248	490	20	M 20 x 60	933	10.9	1415	260	2,4546318	88,6
260	200	224000	430	148	12	160	326	266	490	22	M 20 x 60	933	10.9	1332	228	3,4273171	109
280	220	305000	460	160	12	172	346	289	840	18	M 24 x 70	933	10.9	1246	241	4,8181962	133
300	240	398000	485	160	16	176	366	305	840	21	M 24 x 70	933	10.9	1181	261	6,0332094	148
320	250	433000	520	170	14	184	388	325	840	22	M 24 x 70	931	10.9	1102	244	8,3297625	179
340	260	460000	570	186	14	200	414	349	1250	18	M 27 x 80	933	10.9	1005	223	13,3704682	243
350	270	494000	570	186	14	200	419	359	1250	18	M 27 x 80	933	10.9	1005	222	12,9280867	231
360	280	576000	590	188	22	210	434	365	1250	20	M 27 x 80	931	10.9	971	235	15,9212399	267
390	300	627000	650	205	15	220	470	398	1250	21	M 27 x 90	931	10.9	881	198	24,8087801	345
420	330	973000	715	222	25	247	508	428	1700	20	M 30 x 80	931	10.9	801	235	41,0007733	477
440	350	1160000	750	233	25	258	528	448	1700	22	M 30 x 90	931	10.9	764	234	51,9773030	550
460	370	1307000	770	240	18	258	548	468	1700	23	M 30 x 90	931	10.9	744	227	57,1634855	568
480	390	1435000	800	270	28	298	572	488	1700	24	M 30 x 90	931	10.9	716	197	76,8838095	707
500	410	1650000	825	270	28	298	592	508	1700	26	M 30 x 90	931	10.9	694	206	86,4231353	743
530	440	2105000	890	306	32	338	640	539	2200	25	M 33 x 100	931	10.9	644	198	133,9516584	999
560	460	2276000	940	306	32	338	670	569	2200	26	M 33 x 100	931	10.9	610	196	166,6476108	1114

# 3193 Heavy-Range (strengthened)

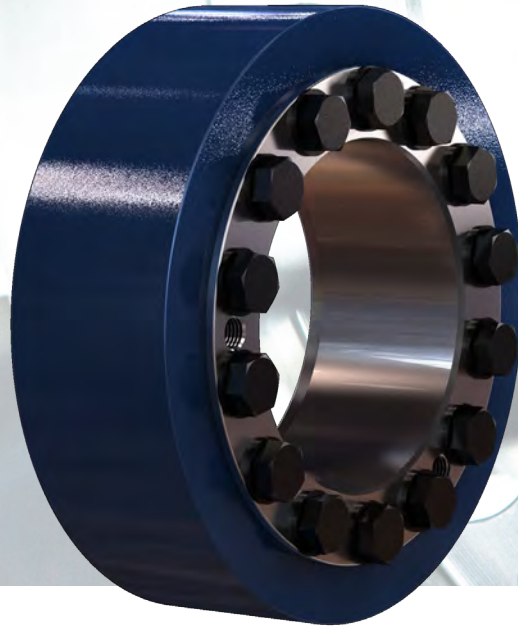
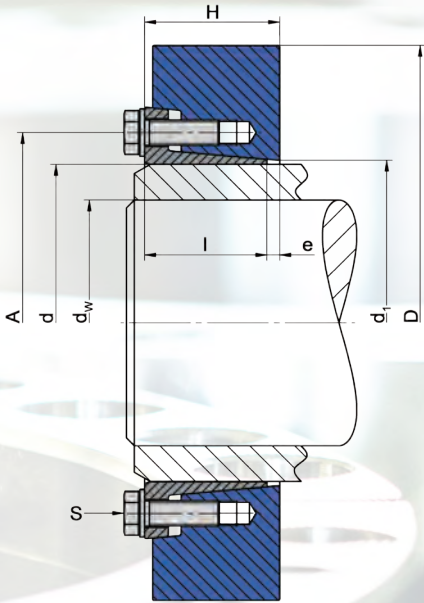

## Used symbols

$d$	[mm]	Nominal diameter of the shrink disc
$d_w$	[mm]	Shaft diameter
$M_{max}$	[mm]	Maximal transmittable torque
$D$	[mm]	Outer diameter
$l$	[mm]	Length of the bush
$e$	[mm]	Excess length
$H$	[mm]	Width of the shrink disc
$A$	[mm]	Pitch circle diameter
$d_1$	[mm]	Attachment size
$M_A$	[Nm]	Tightening torque of the clamping screws
$Z$		Number of clamping screws
$S$		Size of the clamping screws
$n_{max}$	[min <sup>-1</sup> ]	Permitted rotational frequency
$p_N$	[N/mm <sup>2</sup> ]	Average pressure to the hub
$I$	[kgm <sup>2</sup> ]	Moment of inertia

## Design of the shrink disc

$d < 120$	Discs lightly oiled without washers
$d \geq 120$	Disc painted with washers
$d \geq 195$	Cone of bush not slit

Dimensions H & e in unlocked position

min. yield strength Rp0,2	N/mm <sup>2</sup>
Solid shaft	350
Hub	450

## Variation from the standard shaft diameter $d_w$

> mm	≤ mm	minimal - mm	maximal + mm
40	50	-3	2
50	140	-5	5
140	180	-10	5
180	320	-15	10
320	440	-20	10
440	600	-30	10

$$M = M_{max (Catalog)} \left( \frac{d_w (target)}{d_w (Catalog)} \right)^2$$

(see Basics - Calculation)

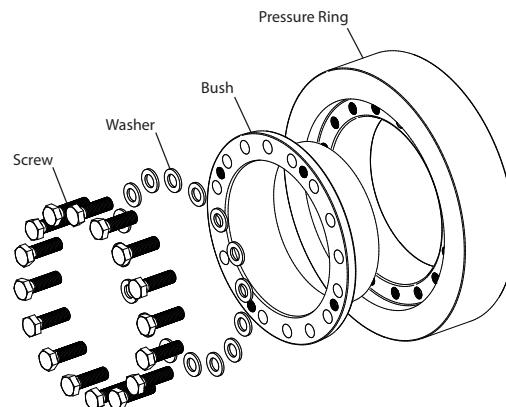

Ordering information: TAS 3193 - d (z.B.: TAS 3193-200 ... further sizes on request)



# 3193 Heavy-Range (strengthened)

<b>d</b> mm	<b>d<sub>w</sub></b> mm	<b>M<sub>max</sub></b> Nm	<b>D</b> mm	<b>l</b> mm	<b>e</b> mm	<b>H</b> mm	<b>A</b> mm	<b>d<sub>1</sub></b> mm	<b>M<sub>A</sub></b> Nm	<b>Z</b> Stk	<b>S</b>	<b>DIN</b>	<b>Class</b>	<b>n<sub>max</sub></b> min <sup>-1</sup>	<b>p<sub>N</sub></b> N/mm <sup>2</sup>	<b>I</b> kgm <sup>2</sup>	<b>Weight</b> kg
110	80	15657	185	65	5	70	139	113	120	10	M 12 x 35	933	12.9	3097	272	0,0508296	8,78
125	90	26187	215	69	6,5	75,5	163	129	290	8	M 16 x 50	933	12.9	2665	337	0,0959929	12,4
135	95	28736	230	69	6,5	75,5	178	144	290	8	M 16 x 50	933	12.9	2491	287	0,1250883	14,1
140	105	35156	230	69	6,5	75,5	178	144	290	8	M 16 x 50	933	12.9	2491	287	0,1278926	14,1
155	115	58406	263	72	9	81	196	159	290	12	M 16 x 50	933	12.9	2179	370	0,2402568	20,6
165	125	71252	290	81	8	89	204	169	290	12	M 16 x 50	933	12.9	1976	330	0,3853659	27,7
175	135	81896	300	81	8	89	214	179	290	12	M 16 x 50	933	12.9	1910	303	0,4359133	28,9
185	145	131546	320	100	12,5	112,5	232	189	570	12	M 20 x 60	933	12.9	1790	368	0,7859084	43,9
200	155	131000	350	102	11	113	246	204	570	14	M 20 x 60	933	12.9	1637	352	1,0778672	53,1
220	165	159000	370	127	9	136	270	225	570	18	M 20 x 60	933	12.9	1549	318	1,5895806	68,6
240	180	209000	405	132	12	144	298	248	570	20	M 20 x 60	933	12.9	1415	305	2,4546318	88,6
260	200	260000	430	150	12	162	326	266	570	22	M 20 x 60	933	12.9	1332	268	3,4273171	109
280	220	354000	460	160	12	172	346	289	980	18	M 24 x 70	933	12.9	1246	283	4,8181962	133
300	240	464000	485	162	16	178	366	305	980	21	M 24 x 70	933	12.9	1181	306	6,0332094	148
320	250	505000	520	170	14	184	388	325	980	22	M 24 x 70	931	12.9	1102	287	8,3297625	179
340	260	536000	570	189	14	203	414	349	1450	18	M 27 x 80	933	12.9	1005	262	13,3704682	243
350	270	576000	570	186	14	200	419	354	1450	18	M 27 x 80	933	12.9	1005	260	12,9280867	231
360	280	671000	590	191	22	213	434	365	1450	20	M 27 x 80	933	12.9	971	276	15,9212399	267
390	300	730000	650	208	15	223	470	398	1450	21	M 27 x 90	931	12.9	881	233	24,8087801	345
420	330	1154000	715	222	25	247	508	428	1950	20	M 30 x 80	931	12.9	801	276	41,0007733	477
440	350	1351000	750	233	25	258	528	448	1950	22	M 30 x 90	931	12.9	764	275	51,9773030	550
460	370	1523000	770	243	18	261	548	468	1950	23	M 30 x 90	931	12.9	744	267	57,1634855	568
480	390	1672000	800	270	28	298	572	488	1950	24	M 30 x 90	931	12.9	716	231	76,8838095	707
500	410	1960000	825	270	28	298	592	508	1950	26	M 30 x 90	931	12.9	694	241	86,4231353	743
530	440	2505000	890	306	32	338	640	539	2600	25	M 33 x 100	931	12.9	644	234	133,9516584	999
560	460	2653000	940	309	32	341	670	569	2600	26	M 33 x 100	931	12.9	610	231	166,6476108	1114

**TAS**  
**SCHÄFER**



# Shrink Discs 2-part

Displacement controlled | External clamping devices



# Description of function

## Two part shrink disc of the types TAS 33..

The main function of a shrink disc is the safe connection of a shaft with a hub by means of friction. For example, between a drive shaft and a transmission hollow shaft. The shrink disc generates a backlash-free connection by pressing the hub onto the shaft. This connection is mainly used to transmit torque.

The shrink disc only provides the required forces, and transfers no forces or moments between shaft and hub by itself. Therefore, the force flow does not pass through it.

It is installed by sliding the shrink disc onto the hollow shaft and the subsequent tightening of the screws. By using conical surfaces the inner diameter reduces and the radial pressure is built up. The 33xx range of shrink discs are self-locking. The clamping forces are provided through the screws.

They are controlled by path (front faces are flush).

The supplied shrink discs are ready for installation.

To achieve proper operation with a sufficiently high coefficient of friction, the contact surfaces between shaft and hub must be dry, clean and free of grease. The functional surfaces of the shrink disc, the thread and head rests of the screws, are equipped at the factory with lubricant. Molykote G-Rapid Plus or comparable must be used as a lubricant. The contact surfaces between the hub and the bush must be provided with grease or oil before installation.

### Product data

A detailed installation manual is available on our Homepage.

Data sheets  
Contact us if a data sheet for an individual product is required.

Desired product is not available, please contact us directly.

CAD data  
We provide CAD data for our products in various formats. Please contact:

**Rolf Gertner**  
rolf.gertner@tas-schaefer.de

or

**Mike Kemper**  
mike.kemper@tas-schaefer.de

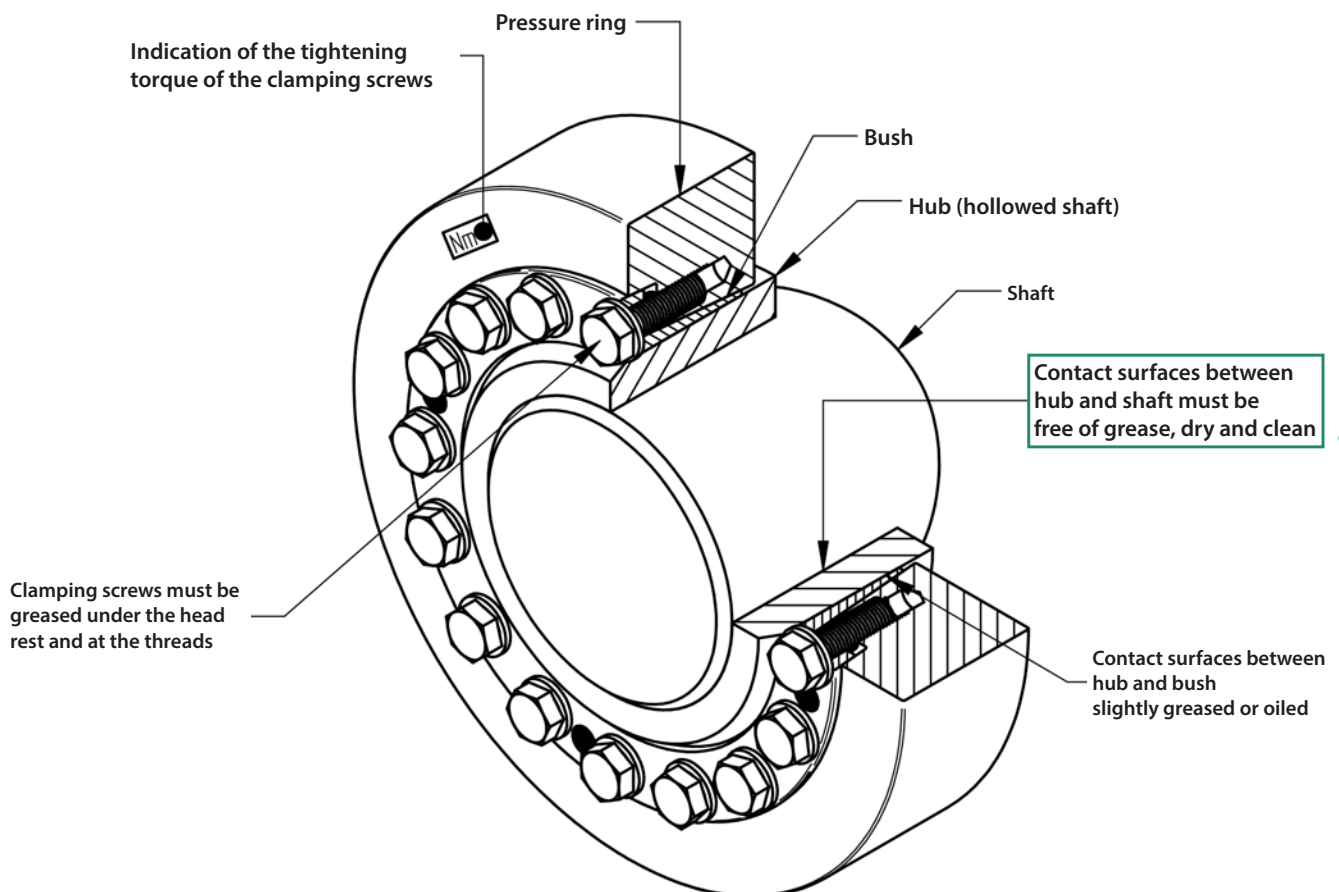

# Basics - Design

## Clamping length for shrink discs

The clamping length  $l$  of the shrink disk at the junction  $l_K$  (between shaft and hub), should be chosen to be somewhat wider to minimize the stress concentration at this point. An excessively wide connection increases the tendency to fretting corrosion, because the pressure decreases outward. The pressure is distributed approximately at an angle between  $15^\circ - 20^\circ$  through the hub. This is largely dependent on the hub wall thickness and stiffness of the shaft. A good approximation can be made from the following equation:

Clamping length of the contact area:  

$$l_K = 0,316(d - d_w) + l$$

The cylindrical surfaces should be located symmetrically under the shrink disc! With a slightly different clamping length the transmissible torque  $M$  will not change, because a smaller contact surface results in a higher pressure - ergo a larger contact surface causes lower pressure.

## Tightening torque of the clamping screws

The given tightening torque values in the tables for the screws are based on a friction coefficient  $\mu_{ges} = 0,1$ .

The values found in the product data based on surface quality and tolerances according to the table below. These values are given as recommendations.

Higher values for the surface roughness reduces the transmissible torque and promote unwanted settling. Larger clearance also reduces the transmissible torque and increases tensions in the hub.

**In the case of significantly different values, please contact us!**

**Tolerance for the outer diameter hub - f7!**

Recommended tolerances and surface roughness				
>	≤	FS <sub>max</sub> mm	Clearance Hub/Shaft	Rz μm
9	18	0,022	H6/h6	10
18	30	0,026	H6/h6	10
30	50	0,032	H6/h6	10
50	80	0,049	H7/h6	10
80	120	0,057	H7/h6	16
120	150	0,065	H7/h6	16
150	180	0,079	H7/g6	16
180	250	0,090	H7/g6	16
250	315	0,101	H7/g6	16
315	400	0,111	H7/g6	16
400	500	0,123	H7/g6	25
500	630	0,136	H7/g6	25
630	800	0,154	H7/g6	25
800	1000	0,172	H7/g6	25



# Basics - Calculation

The calculation of the values, given in the catalogue, are based on the following assumptions and simplifications:

## Transmissible torque

A shrink disc connection is capable of transmitting torque, bending moment and axial force. Alternatively, the transmissible torque  $M_{max}$  is specified in the product data. If such loads occur simultaneously then they must be added vectorially to the resultant moment  $M_{res}$ .

The formula below applies to the resulting moment:

$$M_{res} \leq M_{max}$$

At different load cases, these are individually checked against  $M_{max}$ !  $M_{res}$  is determined for combined loads as follows:

$$M_{res} = \sqrt{M_T^2 + 2M_B^2 + (F_{AX} \frac{d_W}{2})^2}$$

with  $M_B \leq 0,3 M_{max}$   
as the limit\* for the the bending moment

\*In principle, the maximum bending moment corresponds to the maximum transmittable torque. The limitation to  $0,3 M_{max}$  is due to the change of the surface pressure at the edges of the connection. (see also „Bending moment“)

This results in the following relationships:

### Torque only:

The maximum torque is equivalent to  $M_{max}$

### Bending moment only:

The maximum bending moment corresponds to  $0,3 M_{max}$ .

### Axial force only:

The maximum axial force is

$$M_{max} \frac{2}{d_W}$$

A different equation applies for very small shrink discs (3173):

$$M_B \leq 0,2 M_{max}$$

Depending on the application, additional safety factors need to be considered for the individual loads!

## Calculation of transmissible torques and forces

The catalogue data relates to specific shaft diameters which we recommend using. If the shaft diameter is between two sizes, the larger shrink disc should be selected. A deviation is possible within certain limits but the predetermined tolerances and surface roughness should be considered.

The shaft diameter and transmissible torque behave approximately proportional to each other. The transmissible torque increases with greater shaft diameter and vice versa. In contrast, the transmissible axial force changes only slightly. This is not due to the shaft diameter but because of the change in stiffness of the hub when the inner diameter changes.

Within certain limits, the changes can be linearly approximated. Information about the range of the respective shaft diameter can be found in the product data. The determination of the deviating values is explained below. Please contact us if the shaft diameter must be outside the indicated range. The formula below calculates the torque for specific shaft diameters:

$$M = M_{max (Catalog)} \left( \frac{d_W (target)}{d_W (Catalog)} \right)^2$$

The corresponding axial force which is transmitted instead of the torque, results as follows:

$$F_{ax} = M \frac{2}{d_W (table)}$$

## Radial force

Radial forces cause a change in pressure at the contact surface. In the force direction, the pressure increases on the one side and is reduced accordingly on the other side. This depends on the amount of radial force and the rigidity of the parts.

The following equation can be used to approximate the pressure change:

$$\Delta p_W = 0,75 \frac{F_{AX}}{d_W l_K}$$

The modified pressures  $p_{Wmin, max}$  results from the following equation:

$$p_{Wmin, max} = p_W \pm \Delta p_W$$

The minimum pressure  $p_{Wmin}$  should be at least  $50 \text{ N/mm}^2$  to avoid gap corrosion. In addition, the material must be designed for a maximum pressure  $p_{Wmax}$ .

# Basics - Calculation

The calculation of the values, given in the catalogue, are based on the following assumptions and simplifications:

## Bending moment

Here the situation is similar to the radial forces. However the pressure is greatest at the ends of the connection in this case. Again, the amount and stiffness are important. This leads to the following approximation:

$$\Delta p_w = 4,5 \frac{M_B}{d_w l_K^2}$$

As before, the modified pressures results from:

$$p_{wmin, max} = p_w \pm \Delta p_w$$

The conditions for minimum and maximum pressure are the same as before. It should be noted that there could be a change in pressure due to radial force!

## Shaft and hub calculation

The catalogue contains information on the generated surface pressure for each shrink disc. The hub will be deformed due to the applied radial force. In addition to the clearance between shaft and hub, shaft stiffness and surface finish should be considered. For solid shafts the flexibility can be ignored, but with hollow shafts (see „Bore in the shaft (hollow shaft)“) there is greater deformation and thus greater stresses in the components. This must be considered in addition to other loads.

The stresses in the hub can be determined by various hypotheses, such as GEH. We will not make a presentation and analyse results at this point because we would only be able to cover a very limited range of static applications. Various calculation methods for different cases can be found in engineering literature or using specialised software. However, for complex geometry often only a calculation by FEA gives reliable results.

The information on the minimum yield strength of shafts and hubs are suggested recommendations, based on typical values for such applications. They are provided as guidelines and are not a replacement for a proper calculation for a given application!

## Notch effect

Generally there is a notch effect on the components, caused by the radial pressure of the shrink disc. This depends mainly on the applied pressure. The notch effect is generally higher on the hub than on the shaft, because here the inner ring of the shrink disc is directly pressed onto the hub, while the stresses are distributed through the hub before reaching the shaft. The notch factors range from 2,5 to 3,5 for the hub and it is between 1,5 and 2 for the shaft. This can be mitigated by suitable design features, such as relief notches.

Some standards provide the possibility of a notch factor to be determined by a fit pairing for a shrink-connection. A similar method also can be used for a shrink disc connection. To this end an oversize can be calculated from the applied surface pressures. As a result, a matching fit pair can be determine and thus a resultant notch factor found.

## Bore in the shaft (hollow shaft)

A large bore dB in the shaft or the use of a hollow shaft, reduces the stiffness of this component against radial pressure. This leads to a decrease in pressure p<sub>w</sub>, a reduced transmissible torque M, a contraction ΔdB within the shaft and an increase of stresses in these components. Basically, a bore should not be greater than 0,3 d<sub>w</sub>.







**TAS**  
**SCHÄFER**



# 3173 Mini-Range

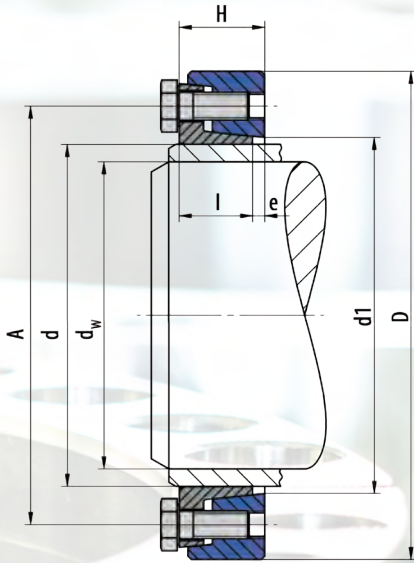

## Used symbols

d	[mm]	Nominal diameter of the shrink disc
dw	[mm]	Shaft diameter
M <sub>max</sub>	[mm]	Maximal transmittable torque
D	[mm]	Outer diameter
l	[mm]	Length of the bush
e	[mm]	Excess length
H	[mm]	Width of the shrink disc
A	[mm]	Pitch circle diameter
d <sub>1</sub>	[mm]	Attachment size
M <sub>A</sub>	[Nm]	Tightening torque of the clamping screws
Z		Number of clamping screws
S		Size of the clamping screws
n <sub>max</sub>	[min <sup>-1</sup> ]	Permitted rotational frequency
p <sub>N</sub>	[N/mm <sup>2</sup> ]	Average pressure to the hub
I	[kgm <sup>2</sup> ]	Moment of inertia

## Design of the shrink disc

- Discs and bush galvanized
- Without washers
- Bush complete slit
- Dimensions H & e in unlocked position

min. yield strength Rp0,2	N/mm <sup>2</sup>
Solid shaft	290
Hub	350

Variation from the standard shaft diameter dW			
> mm	≤ mm	minimal - mm	maximal + mm
20	60	-2	1
60	100	-2	2
100	160	-3	2
160	220	-4	2
220	300	-5	2

$$M = M_{max(Catalog)} \left( \frac{d_W(target)}{d_W(Catalog)} \right)^2$$

(see Basics - Calculation)

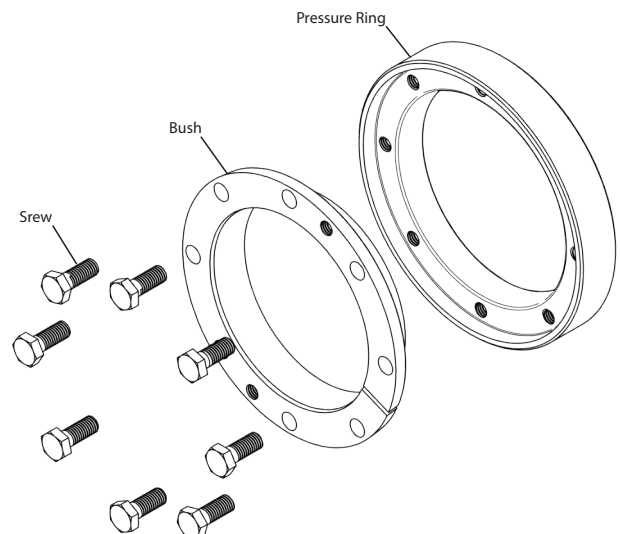

Ordering information: : TAS 3173-d (z.B.: TAS 3173-100 ... further sizes on request)



# 3173 Mini-Range

<b>d</b> mm	<b>d<sub>w</sub></b> mm	<b>M<sub>max</sub></b> Nm	<b>D</b> mm	<b>l</b> mm	<b>e</b> mm	<b>H</b> mm	<b>A</b> mm	<b>d<sub>1</sub></b> mm	<b>M<sub>A</sub></b> Nm	<b>Z</b> Stk	<b>S</b>	<b>DIN</b>	<b>Class</b>	<b>n<sub>max</sub></b> min <sup>-1</sup>	<b>p<sub>N</sub></b> N/mm <sup>2</sup>	<b>I</b> kgm <sup>2</sup>	<b>Weight</b> kg
24	20	150	50	11	2,5	13,5	38	25	12	6	M 6 x 12	933	10.9	11400	252	0,000538	0,14
29	25	220	58	11	2,5	13,5	44	32	12	6	M 6 x 12	933	10.9	9800	227	0,000964	0,18
34	29	220	64	11	2,5	13,5	50	38	12	6	M 6 x 12	933	10.9	8900	180	0,001402	0,21
35	29	220	64	11	2,5	13,5	50	38	12	6	M 6 x 12	933	10.9	8900	186	0,001387	0,21
38	34	280	69	11	2,5	13,5	55	43	12	6	M 6 x 12	933	10.9	8300	153	0,001869	0,24
40	35	310	69	11	2,5	13,5	55	43	12	6	M 6 x 12	933	10.9	8300	162	0,001826	0,23
44	36	380	80	15	3	18	62	49	12	6	M 6 x 16	933	10.9	7100	191	0,004609	0,44
46	38	410	80	15	3	18	62	49	12	6	M 6 x 16	933	10.9	7100	190	0,004518	0,42
47	40	500	80	15	3	18	62	49	12	6	M 6 x 16	933	10.9	7100	196	0,004469	0,42
51	44	550	85	15	3	18	67	54	12	6	M 6 x 16	933	10.9	6700	143	0,005627	0,46
55	48	570	90	15	3	18	72	59	12	8	M 6 x 16	933	10.9	6300	135	0,006993	0,50
56	48	570	90	15	3	18	72	59	12	8	M 6 x 16	933	10.9	6300	132	0,006908	0,49
57	48	570	90	15	3	18	72	59	12	8	M 6 x 16	933	10.9	6300	130	0,006818	0,48
61	53	680	95	15	3	18	76	64	12	8	M 6 x 16	933	10.9	6000	122	0,008373	0,53
65	58	740	100	15	3	18	82	69	12	8	M 6 x 16	933	10.9	5700	108	0,010174	0,57
66	58	740	100	15	3	18	82	69	12	8	M 6 x 16	933	10.9	5700	110	0,010035	0,56
70	62	910	115	21	3	24	94	77	29	6	M 8 x 20	933	10.9	4900	106	0,0026163	1,15
72	63	940	115	21	3	24	94	77	29	6	M 8 x 20	933	10.9	4900	107	0,0025666	1,12
73	63	940	115	21	3	24	94	77	29	6	M 8 x 20	933	10.9	4900	111	0,0025402	1,10
75	67	1140	120	21	3	24	100	82	29	6	M 8 x 20	933	10.9	4700	101	0,0030441	1,21
76	68	1210	120	21	3	24	100	82	29	6	M 8 x 20	933	10.9	4700	103	0,0030170	1,20
78	68	1210	120	21	3	24	100	82	29	6	M 8 x 20	933	10.9	4700	102	0,0029536	1,15
81	73	1240	125	21	3	24	104	87	29	8	M 8 x 20	933	10.9	4500	92	0,0034868	1,26
83	75	1380	125	21	3	24	104	87	29	8	M 8 x 20	933	10.9	4500	95	0,0034103	1,21
85	77	1420	130	21	3	24	110	92	29	8	M 8 x 20	933	10.9	4400	92	0,0040762	1,35
86	78	1470	130	21	3	24	110	92	29	8	M 8 x 20	933	10.9	4400	92	0,0040037	1,32
88	80	1470	130	21	3	24	110	92	29	8	M 8 x 20	933	10.9	4400	95	0,0039124	1,27
93	83	1630	135	21	3,5	24,5	114	97	29	8	M 8 x 20	933	10.9	4200	92	0,0044621	1,33
94	85	1800	135	21	3,5	24,5	114	97	29	8	M 8 x 20	933	10.9	4200	94	0,0044054	1,30
96	88	1730	140	21	3,5	24,5	120	102	29	8	M 8 x 20	933	10.9	4000	83	0,0051883	1,44
98	90	1900	140	21	3,5	24,5	120	102	29	8	M 8 x 20	933	10.9	4000	86	0,0050617	1,39
100	92	2140	145	21	3,5	24,5	124	107	29	8	M 8 x 20	933	10.9	3900	91	0,0059567	1,53
103	95	2310	145	21	3,5	24,5	124	107	29	8	M 8 x 20	933	10.9	3900	92	0,0057132	1,44
106	98	2160	150	21	3,5	24,5	128	112	29	8	M 8 x 20	933	10.9	3800	82	0,0065889	1,56
108	100	2340	150	21	3,5	24,5	128	112	29	8	M 8 x 20	933	10.9	3800	84	0,0064189	1,50
112	103	2340	160	25	4	29	134	119	29	8	M 8 x 20	933	10.9	3500	87	0,0102798	2,16
115	105	2540	160	25	4	29	134	119	29	8	M 8 x 20	933	10.9	3500	91	0,0099175	2,04
120	110	3030	169	25	4	29	140	124	29	8	M 8 x 20	933	10.9	3400	98	0,0106519	2,06
123	113	2910	169	25	4	29	144	129	29	8	M 8 x 20	933	10.9	3300	90	0,0121135	2,22
125	115	3160	169	25	4	29	144	129	29	8	M 8 x 20	933	10.9	3300	93	0,0117986	2,14
130	120	3370	174	25	4	29	150	134	29	12	M 8 x 20	933	10.9	3200	89	0,0130255	2,21
135	125	3810	179	25	4	29	154	139	29	12	M 8 x 20	933	10.9	3200	92	0,0143352	2,28
138	128	3930	184	25	4	29	160	144	29	9	M 8 x 20	933	10.9	3100	92	0,0161739	2,45
140	130	4180	184	25	4	29	160	144	29	9	M 8 x 20	933	10.9	3100	94	0,0157304	2,35

# 3173 Mini-Range

<i>d</i> mm	<i>d<sub>w</sub></i> mm	<i>M<sub>max</sub></i> Nm	<i>D</i> mm	<i>l</i> mm	<i>e</i> mm	<i>H</i> mm	<i>A</i> mm	<i>d<sub>1</sub></i> mm	<i>M<sub>A</sub></i> Nm	<i>Z</i> Stk	<i>S</i>	<i>DIN</i>	<i>Class</i>	<i>n<sub>max</sub></i> min <sup>-1</sup>	<i>p<sub>N</sub></i> N/mm <sup>2</sup>	<i>I</i> kgm <sup>2</sup>	<i>Weight</i> kg
145	135	4650	189	25	4	29	164	149	29	12	M 8 x 20	933	10.9	3000	87	0,0172140	2,43
150	140	5160	194	25	4,5	29,5	170	154	29	12	M 8 x 20	933	10.9	2900	89	0,0187885	2,50
160	150	5390	204	25	4,5	29,5	180	164	29	12	M 8 x 20	933	10.9	2800	81	0,0222215	2,64
166	156	5200	214	25	4,5	29,5	190	174	29	12	M 8 x 20	933	10.9	2600	73	0,0276174	3,01
170	160	5730	214	25	4,5	29,5	190	174	29	12	M 8 x 20	933	10.9	2600	76	0,0260512	2,79
182	170	8350	230	28	5	33	206	186	29	16	M 8 x 20	933	10.9	2400	57	0,0393299	3,66
189	177	8800	240	28	5	33	216	198	29	16	M 8 x 20	933	10.9	2300	54	0,0472032	4,05
192	180	9090	240	28	5	33	216	198	29	16	M 8 x 20	933	10.9	2300	54	0,0452851	3,84
202	190	9670	250	28	5	33	224	206	29	16	M 8 x 20	933	10.9	2200	51	0,0518157	4,01
212	200	10560	260	28	5,5	33,5	234	216	29	16	M 8 x 20	933	10.9	2200	50	0,0589481	4,19
222	210	11660	270	28	5,5	33,5	244	226	29	16	M 8 x 20	933	10.9	2100	50	0,0667091	4,37
232	220	15450	280	28	6	34	254	236	29	16	M 8 x 20	933	10.9	2000	56	0,0751252	4,55
242	230	16220	290	28	6	34	264	246	29	16	M 8 x 20	933	10.9	1900	54	0,0842232	4,72
252	240	17440	300	28	6	34	274	256	29	18	M 8 x 20	933	10.9	1900	53	0,0940295	4,90
260	248	18100	310	28	6,5	34,5	284	266	29	18	M 8 x 20	933	10.9	1800	51	0,1078593	5,27
262	250	18500	310	28	6,5	34,5	284	266	29	18	M 8 x 20	933	10.9	1800	53	0,1045710	5,08





# 3371 Standard-Range

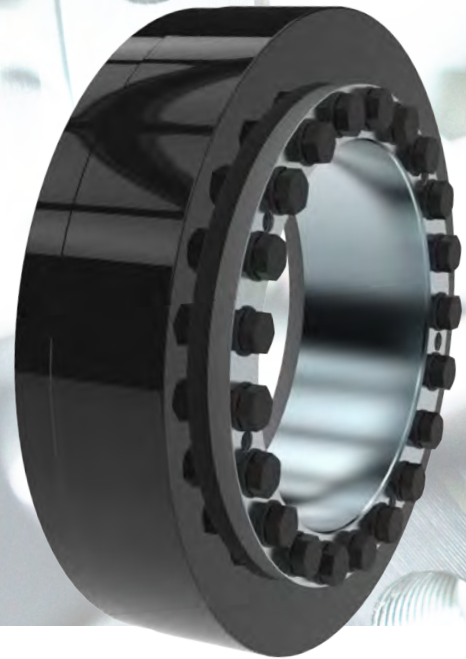
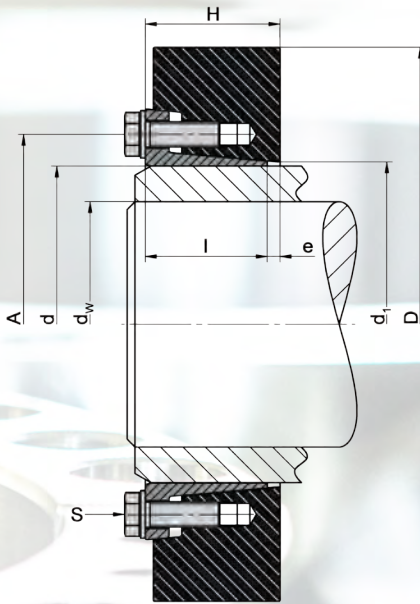

## Used symbols

d	[mm]	Nominal diameter of the shrink disc
$d_w$	[mm]	Shaft diameter
$M_{max}$	[mm]	Maximal transmittable torque
D	[mm]	Outer diameter
l	[mm]	Length of the bush
e	[mm]	Excess length
H	[mm]	Width of the shrink disc
A	[mm]	Pitch circle diameter
$d_1$	[mm]	Attachment size
$M_A$	[Nm]	Tightening torque of the clamping screws
Z		Number of clamping screws
S		Size of the clamping screws
$n_{max}$	[min <sup>-1</sup> ]	Permitted rotational frequency
$p_N$	[N/mm <sup>2</sup> ]	Average pressure to the hub
I	[kgm <sup>2</sup> ]	Moment of inertia

## Design of the shrink disc

$d < 120$	Discs lightly oiled without washers
$d \geq 120$	Disc painted with washers
$d \geq 200$	Cone of bush not slit

Dimensions H & e in unlocked position

min. yield strength $R_{p0,2}$	N/mm <sup>2</sup>
solid shaft	290
Hub	350

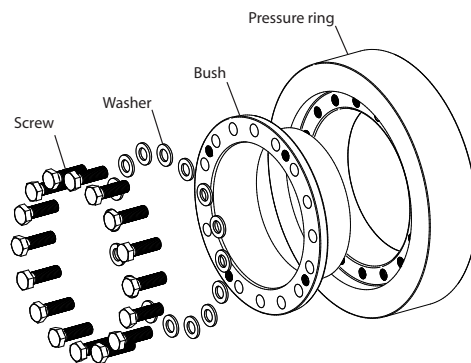

Ordering information: : TAS 3371-d (z.B.: TAS 3371-390 ... further sizes on request)

# 3371 Standard-Range

<b>d</b> mm	<b>d<sub>w</sub></b> mm	<b>M<sub>max</sub></b> Nm	<b>D</b> mm	<b>l</b> mm	<b>e</b> mm	<b>H</b> mm	<b>A</b> mm	<b>d<sub>1</sub></b> mm	<b>M<sub>A</sub></b> Nm	<b>Z</b> Stk	<b>S</b>	<b>DIN</b>	<b>Klasse</b>	<b>n<sub>max</sub></b> min <sup>-1</sup>	<b>p<sub>N</sub></b> N/mm <sup>2</sup>	<b>I</b> kgm <sup>2</sup>	<b>Weight</b> kg
<b>12</b>	9	20	35	10	4	14	24	13	12	3	M6x10	933	10.9	16370	274	0,000012	0,1
	10	40															
	-	-															
<b>14</b>	11	30	38	10	4	14	26	15	12	3	M6x16	933	10.9	15078	241	0,000017	0,1
	12	50															
	-	-															
<b>16</b>	13	70	41	13,5	4	17	28	17	12	3	M6x16	933	10.9	13975	232	0,000030	0,1
	14	90															
	-	-															
<b>18</b>	15	80	44	13,5	4	17	30	19	12	4	M6x16	933	10.9	13022	191	0,000040	0,1
	16	110															
	-	-															
<b>20</b>	17	150	47	13,5	4	17	32	21	12	4	M6x16	933	10.9	12191	233	0,000051	0,2
	18	180															
	-	-															
<b>24</b>	19	160	48	14	4	19	36	26	12	5	M6x16	933	10.9	11937	217	0,000060	0,2
	20	200															
	22	280															
<b>30</b>	24	270	60	16	4	21	44	32	12	6	M6x16	933	10.9	9549	189	0,000164	0,4
	25	320															
	26	360															
<b>36</b>	28	490	72	18	4	22	52	38	30	5	M8x20	933	10.9	7958	208	0,000360	0,5
	30	610															
	33	820															
<b>44</b>	35	690	80	20	5	26	61	47	30	6	M8x20	933	10.9	7162	185	0,000615	0,7
	35	770															
	36	840															
<b>50</b>	38	1.100	90	22	5	28	68	53	30	8	M8x20	933	10.9	6366	202	0,001070	0,9
	40	1.290															
	42	1.500															
<b>55</b>	42	1.230	100	23	5	28	72	58	30	8	M8x20	933	10.9	5730	187	0,001638	1,20
	45	1.530															
	48	1.860															
<b>62</b>	48	1.670	110	23	5	28	80	66	30	9	M8x20	933	10.9	5730	187	0,001638	1,20
	50	1.890															
	52	2.120															
<b>68</b>	50	1.870	115	23	5	28	86	72	30	9	M8x20	933	10.9	4982	192	0,002769	1,4
	55	2.450															
	60	3.120															
<b>75</b>	55	2.330	138	25	5	30	100	79	59	10	M10x025	933	10.9	4152	187	0,006467	2,5
	60	3.020															
	65	3.800															



# 3371 Standard-Range

<b>d</b> mm	<b>d<sub>w</sub></b> mm	<b>M<sub>max</sub></b> Nm	<b>D</b> mm	<b>l</b> mm	<b>e</b> mm	<b>H</b> mm	<b>A</b> mm	<b>d<sub>1</sub></b> mm	<b>M<sub>A</sub></b> Nm	<b>Z</b> Stk	<b>S</b>	<b>DIN</b>	<b>Klasse</b>	<b>n<sub>max</sub></b> min <sup>-1</sup>	<b>p<sub>N</sub></b> N/mm <sup>2</sup>	<b>I</b> kgm <sup>2</sup>	<b>Weight</b> kg
<b>80</b>	60	3.190	141	25	6	31	104	84	59	10	M10x025	933	10.9	4064	199	0,006922	2,5
	65	4.000															
	70	4.900															
<b>90</b>	65	5.400	155	30	6	36	114	94	59	10	M10x025	933	10.9	3697	230	0,011917	3,5
	70	6.500															
	75	7.800															
<b>100</b>	70	6.000	170	34	6	40	124	104	59	12	M10x025	933	10.9	3370	201	0,019335	4,7
	75	7.200															
	80	8.500															
<b>110</b>	80	10.000	185	39	7	46	137	114	100	12	M12x30	933	10.9	3097	209	0,030806	6,3
	85	11.700															
	90	13.600															
<b>120</b>	85	11.900	197	42	7	49	147	126	100	12	M12x30	933	10.9	2908	210	0,041964	7,4
	90	13.800															
	95	15.900															
<b>125</b>	90	14.400	215	42	7	49	152	129	100	12	M12x30	933	10.9	2665	220	0,061151	9,3
	95	16.500															
	100	18.700															
<b>135</b>	95	18.100	230	46	8	54	165	139	160	10	M14x040	933	10.9	2491	225	0,087099	11,5
	100	20.600															
	110	26.000															
<b>140</b>	100	19.600	230	46	8	54	172	146	160	12	M14x040	933	10.9	2491	217	0,085262	11,1
	105	22.100															
	115	27.600															
<b>155</b>	110	26.500	263	50	8	58	186	159	160	12	M14x040	933	10.9	2179	220	0,161225	15,9
	115	29.500															
	125	36.100															
<b>165</b>	120	37.300	290	56	10	66	198	169	250	12	M16x040	933	10.9	1976	226	0,271183	22,2
	125	41.200															
	135	49.600															
<b>175</b>	130	45.000	300	56	10	66	208	179	250	12	M16x040	933	10.9	1910	230	0,306754	23,3
	135	49.000															
	145	58.000															
<b>185</b>	140	64.000	320	71	11	82	222	191	250	16	M16x050	933	10.9	1790	221	0,503920	33,3
	145	70.000															
	155	82.000															
<b>200</b>	150	80.000	340	71	13	84	238	206	250	16	M16x050	933	10.9	1685	241	0,636412	36,9
	155	87.000															
	165	100.000															
<b>220</b>	160	103.000	370	93	14	107	270	230	490	15	M20x060	933	10.9	1549	212	1,31	51,5
	170	119.000															
	180	136.000															

# 3371 Standard-Range

<b>d</b> mm	<b>d<sub>w</sub></b> mm	<b>M<sub>max</sub></b> Nm	<b>D</b> mm	<b>l</b> mm	<b>e</b> mm	<b>H</b> mm	<b>A</b> mm	<b>d<sub>1</sub></b> mm	<b>M<sub>A</sub></b> Nm	<b>Z</b> Stk	<b>S</b>	<b>DIN</b>	<b>Klasse</b>	<b>n<sub>max</sub></b> min <sup>-1</sup>	<b>p<sub>N</sub></b> N/mm <sup>2</sup>	<b>I</b> kgm <sup>2</sup>	<b>Weight</b> kg
<b>240</b>	170	122.000	405	95	14	109	288	248	490	16	M20x060	933	10.9	1415	217	1,70	63,9
	180	140.000															
	200	179.000															
<b>260</b>	190	163.000	430	105	14	119	306	268	490	15	M20x060	933	10.9	1332	208	2,36	77,5
	200	184.000															
	220	231.000															
<b>280</b>	210	215.000	460	114	15	129	328	288	490	16	M20x060	933	10.9	1246	204	3,34	94,7
	220	240.000															
	240	295.000															
<b>300</b>	220	270.000	485	123	17	140	354	308	820	16	M24x070	933	10.9	1181	215	4,40	112
	230	300.000															
	250	363.000															
<b>320</b>	240	301.000	520	125	16	141	380	328	820	18	M24x070	933	10.9	1102	197	5,93	133
	250	332.000															
	270	398.000															
<b>340</b>	250	390.000	570	134	17	151	402	349	820	18	M24x070	933	10.9	1005	223	9,35	177
	260	427.000															
	280	506.000															
<b>350</b>	270	493.000	580	140	18	158	414	365	820	20	M24x070	933	10.9	988	223	10,40	190
	280	535.000															
	290	580.000															
<b>360</b>	270	496.000	590	140	18	158	424	369	820	20	M24x070	933	10.9	971	226	11,06	194
	280	539.000															
	300	631.000															
<b>380</b>	290	585.000	640	146	18	164	444	388	1210	18	M27x070	933	10.9	895	219	16,23	244
	300	632.000															
	310	681.000															
<b>390</b>	290	640.000	645	146	19	165	454	398	1210	18	M27x080	933	10.9	888	240	16,56	243
	300	691.000															
	320	799.000															
<b>420</b>	320	742.000	670	167	19	186	490	428	1210	18	M27x080	933	10.9	855	201	21,51	286
	330	797.000															
	350	912.000															
<b>440</b>	340	945.000	710	174	23	197	506	448	1210	21	M27x080	933	10.9	807	215	28,49	339
	350	1.009.000															
	370	1.143.000															
<b>460</b>	360	1.104.000	745	174	24	198	534	470	1210	21	M27x090	933	10.9	769	223	34,62	375
	370	1.174.000															
	390	1.320.000															
<b>480</b>	380	1.300.000	770	192	25	217	552	488	1640	20	M30x090	933	10.9	744	219	43,28	437
	390	1.378.000															
	410	1.541.000															



# 3371 Standard-Range

<b>d</b> mm	<b>d<sub>w</sub></b> mm	<b>M<sub>max</sub></b> Nm	<b>D</b> mm	<b>l</b> mm	<b>e</b> mm	<b>H</b> mm	<b>A</b> mm	<b>d<sub>1</sub></b> mm	<b>M<sub>A</sub></b> Nm	<b>Z</b> Stk	<b>S</b>	<b>DIN</b>	<b>Klasse</b>	<b>n<sub>max</sub></b> min <sup>-1</sup>	<b>p<sub>N</sub></b> N/mm <sup>2</sup>	<b>I</b> kgm <sup>2</sup>	<b>Weight</b> kg
<b>500</b>	400	1.496.000	800	192	26	218	572	508	1640	21	M30x090	933	10.9	716	219	50,34	470
	410	1.581.000															
	430	1.759.000															
<b>530</b>	430	1.930.000	845	213	30	243	606	541	1640	24	M30x100	933	10.9	678	220	69,62	576
	440	2.031.000															
	460	2.243.000															
<b>560</b>	450	2.097.000	900	213	30	243	632	568	1640	24	M30x100	933	10.9	637	218	90,11	660
	460	2.201.000															
	480	2.420.000															
<b>590</b>	470	2.593.000	950	230	31	261	664	598	1640	28	M30x100	933	10.9	603	228	120,87	821
	480	2.715.000															
	500	2.970.000															
<b>620</b>	500	2.904.000	960	254	33	287	706	630	1640	28	M30x100	933	10.9	597	204	134,96	872
	520	3.169.000															
	540	3.447.000															
<b>660</b>	530	3.329.000	1020	260	35	295	748	670	2200	24	M33x110	933	10.9	562	204	175,74	1004
	550	3.614.000															
	570	3.911.000															
<b>700</b>	560	3.804.000	1080	260	37	297	782	710	2200	28	M33x120	933	10.9	531	208	220,57	1141
	580	4.109.000															
	600	4.427.000															
<b>750</b>	600	4.801.000	1150	278	41	319	848	760	2200	32	M33x120	933	10.9	498	213	301,41	1346
	620	5.157.000															
	650	5.716.000															
<b>800</b>	640	5.620.000	1230	296	42	338	900	810	2200	32	M33x130	933	10.9	466	207	420,80	1646
	660	6.012.000															
	700	6.839.000															
<b>850</b>	650	5.942.000	1300	315	44	359	950	860	2850	30	M36x130	933	10.9	441	201	555,97	1942
	700	6.994.000															
	730	7.669.000															
<b>900</b>	700	6.967.000	1350	332	47	379	1000	915	2850	32	M36x140	933	10.9	424	192	668,94	2142
	730	7.640.000															
	760	8.345.000															
<b>950</b>	750	8.295.000	1400	360	49	409	1050	965	2850	36	M36x140	933	10.9	409	183	823,40	2425
	780	9.041.000															
	820	10.088.000															
<b>1000</b>	800	9.568.000	1420	380	60	440	1100	1020	2850	36	M36x160	933	10.9	402	175	880,02	2740
	830	10.380.000															
	860	11.228.000															
<b>1050</b>	850	11.241.000	1520	400	58	458	1150	1070	2850	36	M36x160	933	10.9	377	173	1245,24	3078
	880	12.135.000															
	920	13.383.000															

# 3371 Standard-Range

<i>d</i> mm	<i>d<sub>w</sub></i> mm	<i>M<sub>max</sub></i> Nm	<i>D</i> mm	<i>l</i> mm	<i>e</i> mm	<i>H</i> mm	<i>A</i> mm	<i>d<sub>1</sub></i> mm	<i>M<sub>A</sub></i> Nm	<i>Z</i> Stk	<i>S</i>	<i>DIN</i>	<i>Klasse</i>	<i>n<sub>max</sub></i> min <sup>-1</sup>	<i>p<sub>N</sub></i> N/mm <sup>2</sup>	<i>I</i> kgm <sup>2</sup>	<i>Weight</i> kg
<b>1100</b>	900	13.045.000	1570	430	61	491	1200	1120	2850	40	M36x170	933	10.9	365	166	1496,97	3438
	930	14.023.000															
	960	15.038.000															
<b>1200</b>	940	12.902.000	1630	460	66	526	1300	1220	2850	40	M36x180	933	10.9	352	143	1730,72	3566
	1000	14.803.000															
	1050	16.493.000															

# 3381 Standard-Range (strengthened)

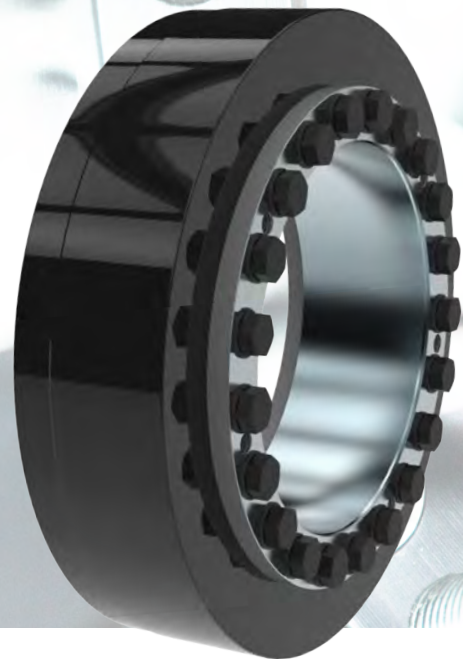
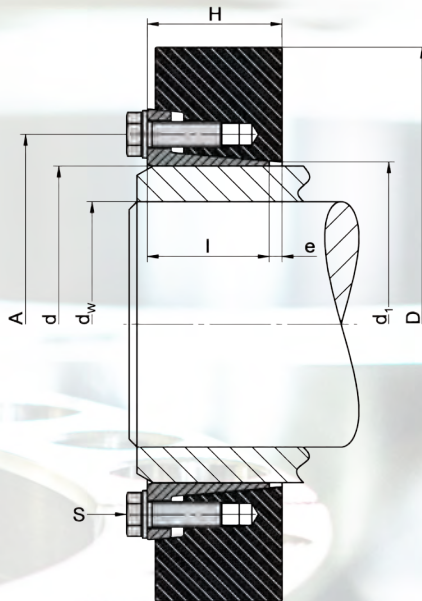

## Used symbols

d	[mm]	Nominal diameter of the shrink disc
$d_w$	[mm]	Shaft diameter
$M_{max}$	[mm]	Maximal transmittable torque
D	[mm]	Outer diameter
l	[mm]	Length of the bush
e	[mm]	Excess length
H	[mm]	Width of the shrink disc
A	[mm]	Pitch circle diameter
$d_1$	[mm]	Attachment size
$M_A$	[Nm]	Tightening torque of the clamping screws
Z		Number of clamping screws
S		Size of the clamping screws
$n_{max}$	[min <sup>-1</sup> ]	Permitted rotational frequency
$p_N$	[N/mm <sup>2</sup> ]	Average pressure to the hub
I	[kgm <sup>2</sup> ]	Moment of inertia

## Design of the shrink disc

$d < 120$	Discs lightly oiled without washers
$d \geq 120$	Disc painted with washers
$d \geq 200$	Cone of bush not slit

Dimensions H & e in unlocked position

min. yield strength Rp0,2	N/mm <sup>2</sup>
solid shaft	350
Hub	450

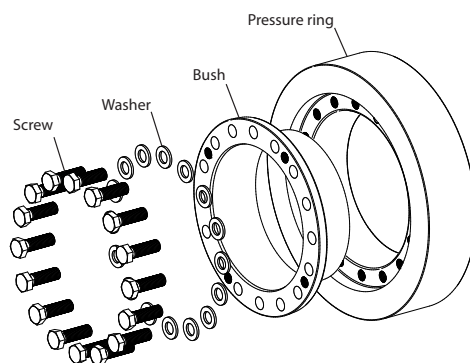

Ordering information: : TAS 3381-d (z.B.: TAS 3381-390 ... further sizes on request)



# 3381 Standard-Range (strengthened)

<b>d</b> mm	<b>d<sub>w</sub></b> mm	<b>M<sub>max</sub></b> Nm	<b>D</b> mm	<b>l</b> mm	<b>e</b> mm	<b>H</b> mm	<b>A</b> mm	<b>d<sub>1</sub></b> mm	<b>M<sub>A</sub></b> Nm	<b>Z</b> Stk	<b>S</b>	<b>DIN</b>	<b>Klasse</b>	<b>n<sub>max</sub></b> min <sup>-1</sup>	<b>p<sub>N</sub></b> N/mm <sup>2</sup>	<b>I</b> kgm <sup>2</sup>	<b>Weight</b> kg
<b>50</b>	38	1.500	90	22	5	27	68	53	35	8	M8x20	933	12.9	6366	265	0,001026	0,9
	40	1.700															
	42	2.000															
<b>55</b>	42	1.600	100	23	5	28	72	58	35	8	M8x20	933	12.9	5730	225	0,001638	1,2
	45	2.000															
	48	2.400															
<b>62</b>	48	2.200	110	23	5	28	80	66	35	9	M8x20	933	12.9	5209	225	0,002374	1,4
	50	2.500															
	52	2.700															
<b>68</b>	50	2.400	115	23	6	29	86	72	35	9	M8x20	933	12.9	4982	216	0,002769	1,4
	55	3.000															
	60	3.800															
<b>75</b>	55	3.700	138	25	6	31	100	79	70	10	M10x025	933	12.9	4152	264	0,006467	2,5
	60	4.700															
	65	5.800															
<b>80</b>	60	4.200	141	25	6	31	104	84	70	10	M10x025	933	12.9	4064	247	0,006922	2,5
	65	5.200															
	70	6.300															
<b>90</b>	65	5.900	155	30	6	36	114	94	70	10	M10x025	933	12.9	3697	247	0,011917	3,5
	70	7.200															
	75	8.500															
<b>100</b>	70	7.400	170	34	7	41	124	104	70	12	M10x025	933	12.9	3370	237	0,019335	4,7
	75	8.900															
	80	10.400															
<b>110</b>	80	12.600	185	39	7	46	137	114	120	12	M12x040	933	12.9	3097	253	0,030806	6,3
	85	14.600															
	90	16.900															
<b>120</b>	85	13.600	197	42	7	49	147	126	120	12	M12x040	933	12.9	2908	234	0,041964	7,8
	90	15.700															
	95	18.000															
<b>125</b>	90	16.400	215	42	7	49	152	129	120	12	M12x040	933	12.9	2665	245	0,061151	9,3
	95	18.800															
	100	21.300															
<b>135</b>	95	20.300	230	46	8	54	165	139	190	10	M14x040	933	12.9	2491	247	0,087099	11,5
	100	23.000															
	110	29.000															
<b>140</b>	100	23.000	230	46	9	55	172	146	190	12	M14x040	933	12.9	2491	249	0,085262	11,5
	105	25.900															
	115	32.200															
<b>155</b>	110	31.100	263	50	9	59	186	159	190	12	M14x040	933	12.9	2179	249	0,161225	16
	115	34.600															
	125	42.100															

# 3381 Standard-Range (strengthened)

<b>d</b> mm	<b>d<sub>w</sub></b> mm	<b>M<sub>max</sub></b> Nm	<b>D</b> mm	<b>l</b> mm	<b>e</b> mm	<b>H</b> mm	<b>A</b> mm	<b>d<sub>1</sub></b> mm	<b>M<sub>A</sub></b> Nm	<b>Z</b> Stk	<b>S</b>	<b>DIN</b>	<b>Klasse</b>	<b>n<sub>max</sub></b> min <sup>-1</sup>	<b>p<sub>N</sub></b> N/mm <sup>2</sup>	<b>I</b> kgm <sup>2</sup>	<b>Weight</b> kg
<b>165</b>	120	44.000	290	56	10	66	198	169	290	12	M16x040	933	12.9	1976	261	0,271183	23
	125	48.500															
	135	58.100															
<b>175</b>	130	54.000	300	56	11	67	208	179	290	12	M16x050	933	12.9	1910	271	0,306754	24
	135	59.000															
	145	70.000															
<b>185</b>	140	81.000	320	71	12	83	222	191	290	16	M16x050	933	12.9	1790	272	0,503920	34
	145	88.000															
	155	102.000															
<b>200</b>	150	96.000	340	71	14	85	238	206	290	12	M16x050	933	12.9	1685	283	0,636412	37
	155	103.000															
	165	119.000															
<b>220</b>	160	129.000	370	93	15	108	270	230	570	15	M20x060	933	12.9	1549	259	1,16	52
	170	149.000															
	180	170.000															
<b>240</b>	170	151.000	405	95	15	110	288	248	570	16	M20x060	933	12.9	1415	262	1,70	64
	180	172.000															
	200	220.000															
<b>260</b>	190	212.000	430	105	17	122	306	268	570	15	M20x060	933	12.9	1332	264	2,36	78
	200	239.000															
	220	298.000															
<b>280</b>	210	279.000	46	114	17	131	328	288	570	16	M20x060	933	12.9	1246	258	3,34	95
	220	311.000															
	240	379.000															
<b>300</b>	220	332.000	485	123	19	142	354	308	900	16	M24x070	933	12.9	1181	260	4,40	113
	230	367.000															
	250	444.000															
<b>320</b>	240	404.000	520	125	19	144	380	328	900	18	M24x070	933	12.9	1102	258	5,93	133
	250	444.000															
	270	530.000															
<b>340</b>	250	489.000	570	134	19	153	402	349	900	18	M24x070	933	12.9	1005	268	9,35	178
	260	534.000															
	280	632.000															
<b>350</b>	270	625.000	580	140	21	161	414	365	900	20	M24x070	933	12.9	988	276	10,40	185
	280	670.000															
	290	730.000															
<b>360</b>	270	625.000	590	140	21	161	424	369	900	20	M24x080	933	12.9	971	279	11,06	195
	280	678.000															
	300	791.000															
<b>390</b>	290	780.000	650	146	21	167	454	398	1310	18	M27x080	933	12.9	882	288	17,16	249
	300	845.000															
	320	975.000															

# 3381 Standard-Range (strengthened)

<b>d</b> mm	<b>d<sub>w</sub></b> mm	<b>M<sub>max</sub></b> Nm	<b>D</b> mm	<b>l</b> mm	<b>e</b> mm	<b>H</b> mm	<b>A</b> mm	<b>d<sub>1</sub></b> mm	<b>M<sub>A</sub></b> Nm	<b>Z</b> Stk	<b>S</b>	<b>DIN</b>	<b>Klasse</b>	<b>n<sub>max</sub></b> min <sup>-1</sup>	<b>p<sub>N</sub></b> N/mm <sup>2</sup>	<b>I</b> kgm <sup>2</sup>	<b>Weight</b> kg
<b>420</b>	320	970.000	680	167	22	189	490	428	1310	18	M27x080	933	12.9	843	258	23,06	300
	330	1.040.000															
	350	1.190.000															
<b>440</b>	340	1.215.000	725	174	26	200	506	448	1310	21	M27x090	933	12.9	791	272	31,40	363
	350	1.295.000															
	370	1.465.000															
<b>460</b>	360	1.400.000	745	174	28	202	534	470	1310	21	M27x100	933	12.9	769	277	34,62	376
	370	1.485.000															
	390	1.670.000															
<b>480</b>	380	1.660.000	790	192	27	219	552	488	1800	20	M30x100	933	12.9	726	267	48,79	476
	390	1.760.000															
	410	1.965.000															
<b>500</b>	400	1.890.000	835	192	28	220	572	508	1800	21	M30x100	933	12.9	687	273	61,43	540
	410	1.995.000															
	430	2.217.000															
<b>530</b>	430	2.400.000	890	213	31	244	606	541	1800	24	M30x100	933	12.9	644	270	88,61	680
	440	2.525.000															
	460	2.785.000															
<b>560</b>	450	2.550.000	920	213	32	245	632	568	1800	24	M30x100	933	12.9	623	262	99,85	710
	460	2.675.000															
	480	2.935.000															
<b>590</b>	470	2.970.000	960	230	33	263	664	598	1800	28	M30x110	933	12.9	597	259	126,94	830
	480	3.110.000															
	500	3.400.000															
<b>620</b>	500	3.405.000	970	254	35	289	706	630	1800	28	M30x110	933	12.9	591	238	141,87	900
	520	3.715.000															
	540	4.040.000															
<b>660</b>	530	4.035.000	1060	260	36	296	748	670	2400	24	M33x120	933	12.9	541	245	211,19	1120
	550	4.375.000															
	570	4.730.000															
<b>700</b>	560	4.605.000	1140	260	38	298	782	710	2400	28	M33x120	933	12.9	503	250	285,23	1320
	580	4.970.000															
	600	5.350.000															
<b>750</b>	600	5.810.000	1200	278	43	321	848	760	2400	32	M33x130	933	12.9	478	256	369,70	1540
	620	6.231.000															
	650	6.900.000															
<b>800</b>	640	6.800.000	1270	296	45	341	900	810	2400	32	M33x130	933	12.9	451	248	490,80	1835
	660	7.270.000															
	700	8.250.000															
<b>850</b>	650	7.215.000	1340	315	47	362	950	860	3100	30	M36x140	933	12.9	428	242	643,65	2154
	700	8.475.000															
	730	9.275.000															



# 3381 Standard-Range (strengthened)

<b>d</b> mm	<b>d<sub>W</sub></b> mm	<b>M<sub>max</sub></b> Nm	<b>D</b> mm	<b>l</b> mm	<b>e</b> mm	<b>H</b> mm	<b>A</b> mm	<b>d<sub>i</sub></b> mm	<b>M<sub>A</sub></b> Nm	<b>Z</b> Stk	<b>S</b>	<b>DIN</b>	<b>Klasse</b>	<b>n<sub>max</sub></b> min <sup>-1</sup>	<b>p<sub>N</sub></b> N/mm <sup>2</sup>	<b>I</b> kgm <sup>2</sup>	<b>Weight</b> kg
<b>900</b>	700	8.455.000	1400	332	49	381	1000	915	3100	32	M36x140	933	12.9	409	231	799,46	2433
	730	9.260.000															
	760	10.100.000															
<b>950</b>	750	10.070.000	1450	360	51	411	1050	965	3100	36	M36x150	933	12.9	395	220	980,86	2752
	780	10.950.000															
	820	12.200.000															
<b>1000</b>	800	11.300.000	1470	380	61	441	1100	1020	3100	36	M36x170	933	12.9	390	205	1053,28	2700
	830	12.300.000															
	860	13.200.000															
<b>1050</b>	850	13.000.000	1520	400	65	465	1150	1070	3100	40	M36x170	933	12.9	377	199	1245,24	3200
	880	14.000.000															
	920	15.400.000															

# 3391 Heavy-Range

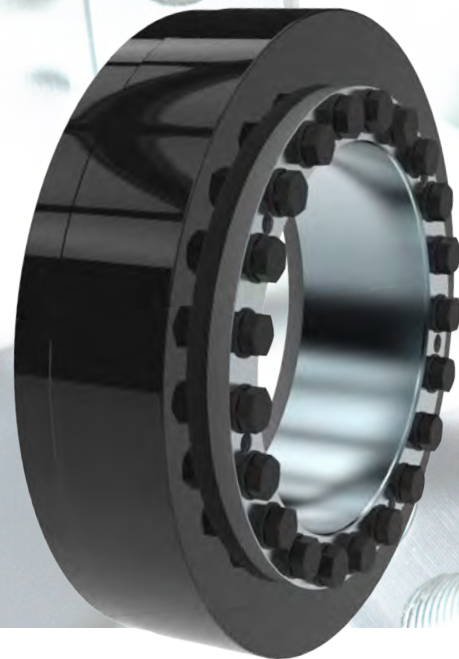
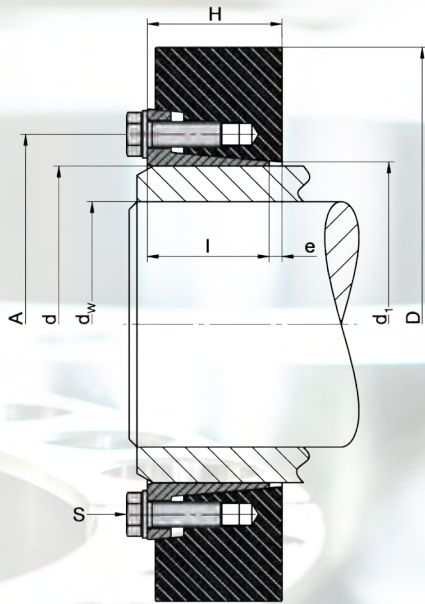

## Used symbols

d	[mm]	Nominal diameter of the shrink disc
$d_w$	[mm]	Shaft diameter
$M_{max}$	[mm]	Maximal transmittable torque
D	[mm]	Outer diameter
l	[mm]	Length of the bush
e	[mm]	Excess length
H	[mm]	Width of the shrink disc
A	[mm]	Pitch circle diameter
$d_1$	[mm]	Attachment size
$M_A$	[Nm]	Tightening torque of the clamping screws
Z		Number of clamping screws
S		Size of the clamping screws
$n_{max}$	[min <sup>-1</sup> ]	Permitted rotational frequency
$p_N$	[N/mm <sup>2</sup> ]	Average pressure to the hub
I	[kgm <sup>2</sup> ]	Moment of inertia

## Design of the shrink disc

	Disc painted with washers
$d \geq 200$	Cone of bush not slit

Dimensions H & e in unlocked position

min. yield strength $R_{p0,2}$	$N/mm^2$
solid shaft	290
Hub	350

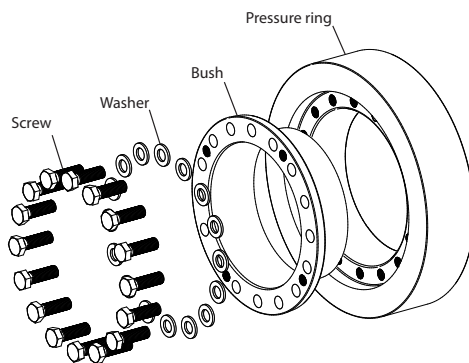

Ordering information: : TAS 3391-d (z.B.: TAS 3391-390 ... further sizes on request)

# 3391 Heavy-Range

<b>d</b> mm	<b>d<sub>w</sub></b> mm	<b>M<sub>max</sub></b> Nm	<b>D</b> mm	<b>l</b> mm	<b>e</b> mm	<b>H</b> mm	<b>A</b> mm	<b>d<sub>1</sub></b> mm	<b>M<sub>A</sub></b> Nm	<b>Z</b> Stk	<b>S</b>	<b>DIN</b>	<b>Klasse</b>	<b>n<sub>max</sub></b> min <sup>-1</sup>	<b>p<sub>N</sub></b> N/mm <sup>2</sup>	<b>I</b> kgm <sup>2</sup>	<b>Weight</b> kg
<b>140</b>	100	26.000	230	60	10	70	174	144	250	8	M16x040	933	10.9	2491	221	0,110659	13,6
	105	30.000															
	115	37.000															
<b>155</b>	110	36.000	263	66	10	76	194	160	250	9	M16x040	933	10.9	2179	225	0,211805	19,8
	115	40.000															
	125	48.000															
<b>165</b>	120	50.000	290	72	10	82	200	169	250	12	M16x040	933	10.9	1976	234	0,347305	27,7
	125	55.000															
	135	66.000															
<b>175</b>	130	61.000	300	72	11	83	210	179	250	12	M16x050	933	10.9	1910	241	0,392860	29
	135	67.000															
	145	79.000															
<b>185</b>	140	89.000	320	92	12	104	232	190	490	12	M20x050	933	10.9	1790	235	0,650897	40,1
	145	96.000															
	155	113.000															
<b>200</b>	150	104.000	340	92	13	105	246	204	490	12	M20x050	933	10.9	1685	242	0,822032	44,5
	155	113.000															
	165	130.000															
<b>220</b>	160	127.000	370	117	13	130	266	224	490	15	M20x050	933	10.9	1549	209	1,45	65,3
	170	137.000															
	180	169.000															
<b>240</b>	170	157.000	405	122	13	135	286	244	490	16	M20x060	933	10.9	1415	218	2,18	81,6
	180	180.000															
	200	230.000															
<b>260</b>	190	230.000	430	136	17	153	306	265	490	18	M20x060	933	10.9	1332	225	3,05	101
	200	260.000															
	220	325.000															
<b>280</b>	210	306.000	460	148	18	166	334	285	840	16	M24x70	933	10.9	1246	222	4,32	126
	220	342.000															
	240	418.000															
<b>300</b>	220	360.000	485	152	19	171	354	305	840	16	M24x70	933	10.9	1181	209	5,43	140
	230	398.000															
	250	437.000															
<b>320</b>	240	430.000	520	160	20	180	374	325	840	18	M24x70	933	10.9	1102	218	7,58	171
	250	473.000															
	270	565.000															
<b>340</b>	250	551.000	560	176	22	198	404	345	1250	18	M27x080	933	10.9	1023	233	11,37	221
	260	603.000															
	280	714.000															
<b>350</b>	270	600.000	570	180	22	202	414	361	1250	18	M27x080	933	10.9	1005	212	12,32	236
	280	650.000															
	290	710.000															



# 3391 Heavy-Range

<b>d</b> mm	<b>d<sub>w</sub></b> mm	<b>M<sub>max</sub></b> Nm	<b>D</b> mm	<b>l</b> mm	<b>e</b> mm	<b>H</b> mm	<b>A</b> mm	<b>d<sub>1</sub></b> mm	<b>M<sub>A</sub></b> Nm	<b>Z</b> Stk	<b>S</b>	<b>DIN</b>	<b>Klasse</b>	<b>n<sub>max</sub></b> min <sup>-1</sup>	<b>p<sub>N</sub></b> N/mm <sup>2</sup>	<b>I</b> kgm <sup>2</sup>	<b>Weight</b> kg
<b>360</b>	270	671.000	590	180	22	202	424	365	1250	18	M27x080	933	10.9	971	236	14,20	249
	280	729.000															
	300	852.000															
<b>390</b>	290	850.000	650	190	25	215	456	398	1250	20	M27x090	933	10.9	881,473531	244,253884	22,30	324
	300	917.000															
	320	1.061.000															
<b>420</b>	320	1.008.000	670	214	26	240	486	428	1250	21	M27x090	933	10.9	855,1608883	212,2902805	27,53	367
	330	1.082.000															
	350	1.237.000															
<b>440</b>	340	1.218.000	740	225	26	251	514	448	1640	21	M30x090	933	10.9	774,2672907	235,709111	44,56	508
	350	1.301.000															
	370	1.475.000															
<b>460</b>	360	1.402.000	750	226	27	253	534	468	1640	21	M30x100	933	10.9	763,9437268	217,1658389	46,33	485
	370	1.491.000															
	390	1.678.000															
<b>480</b>	380	1.712.000	760	246	29	275	552	488	1640	21	M30x100	933	10.9	753,8918357	217,3324297	52,07	537
	390	1.814.000															
	410	2.028.000															
<b>500</b>	400	1.993.000	800	246	30	276	572	508	1640	24	M30x100	933	10.9	716,1972439	226,8337117	64,42	604
	410	2.106.000															
	430	2.342.000															
<b>530</b>	430	2.549.000	860	276	32	312	616	538	2210	21	M33x110	933	10.9	666,2299943	223,395598	99,19	794
	440	2.683.000															
	460	2.962.000															
<b>560</b>	450	2.849.000	900	280	34	314	646	568	2210	24	M33x110	933	10.9	636,6197724	224,5460525	118,19	867
	460	2.990.000															
	480	3.285.000															
<b>590</b>	470	3.310.000	960	296	34	330	672	600	2210	24	M33x110	933	10.9	596,8310366	225,9241121	163,05	1071
	480	3.467.000															
	500	3.793.000															
<b>620</b>	500	4.069.000	1000	330	35	365	706	630	2210	27	M33x110	933	10.9	572,9577951	219,3400416	212,60	1279
	520	4.251.000															
	540	4.824.000															
<b>660</b>	530	4.746.000	1070	334	38	372	750	670	2850	27	M36x120	933	10.9	535,4745749	225,3140418	283,03	1475
	550	4.944.000															
	570	5.566.000															
<b>700</b>	560	5.316.000	1070	334	45	379	802	710	2850	27	M36x130	933	10.9	535,4745749	225,5805788	270,32	1387
	580	5.525.000															
	600	6.179.000															
<b>750</b>	600	6.326.000	1170	360	43	413	852	760	2850	30	M36x130	933	10.9	489,7075172	216,6424012	435,35	1810
	620	6.794.000															
	650	7.530.000															

# 3391 Heavy-Range

<b>d</b> mm	<b>d<sub>W</sub></b> mm	<b>M<sub>max</sub></b> Nm	<b>D</b> mm	<b>l</b> mm	<b>e</b> mm	<b>H</b> mm	<b>A</b> mm	<b>d<sub>1</sub></b> mm	<b>M<sub>A</sub></b> Nm	<b>Z</b> Stk	<b>S</b>	<b>DIN</b>	<b>Klasse</b>	<b>n<sub>max</sub></b> min <sup>-1</sup>	<b>p<sub>N</sub></b> N/mm <sup>2</sup>	<b>I</b> kgm <sup>2</sup>	<b>Weight</b> kg
<b>800</b>	640	7.358.000	1280	360	43	403	900	810	2850	35	M36x130	933	10.9	447,6232774	221,6397391	618,75	2290
	660	7.871.000															
	700	8.952.000															
<b>850</b>	650	7.700.000	1360	380	44	424	950	860	2850	36	M36x130	933	10.9	421,2924964	214,6803652	832,12	2588
	700	9.000.000															
	730	10.000.000															
<b>900</b>	700	9.000.000	1400	400	47	447	1010	912	2850	38	M36x140	933	10.9	409,255568	204,717819	962,23	2779
	730	9.900.000															
	760	10.800.000															
<b>950</b>	750	11.300.000	1460	430	52	482	1050	970	2850	44	M36x150	933	10.9	392,436846	207,0315436	1210,53	3192
	780	12.300.000															
	820	13.700.000															
<b>1000</b>	800	13.000.000	1500	460	57	487	1050	1020	2850	44	M36x160	933	10.9	382	195	1318,72	3246
	830	14.100.000															
	860	15.200.000															
<b>1050</b>	850	13.800.000	1530	480	58	538	1160	1070	2850	44	M36x160	933	10.9	374	176	1544,43	3588
	880	14.900.000															
	920	16.300.000															

# 3393 Heavy-Range (strengthened)

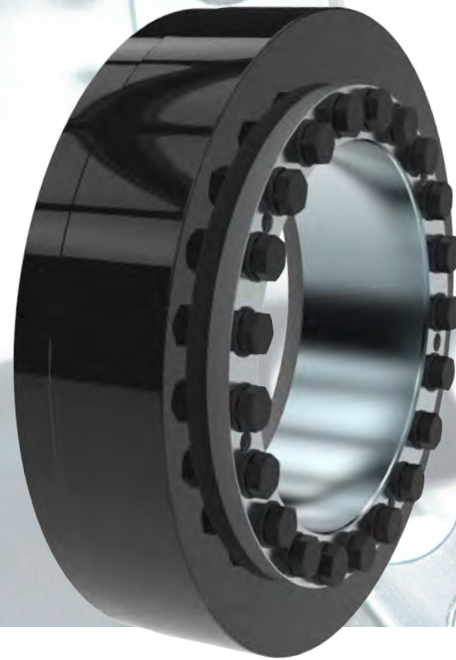
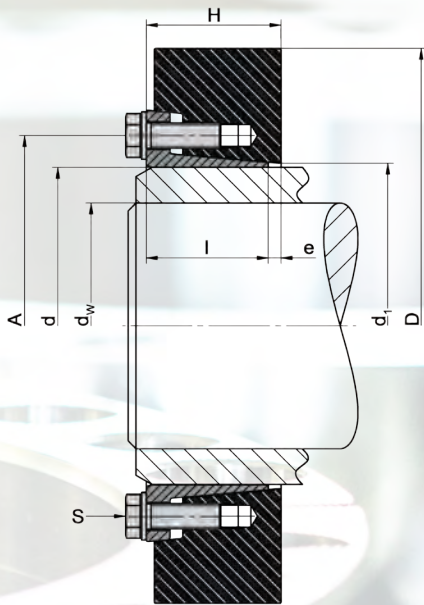

## Used symbols

d	[mm]	Nominal diameter of the shrink disc
$d_w$	[mm]	Shaft diameter
$M_{max}$	[mm]	Maximal transmittable torque
D	[mm]	Outer diameter
l	[mm]	Length of the bush
e	[mm]	Excess length
H	[mm]	Width of the shrink disc
A	[mm]	Pitch circle diameter
$d_1$	[mm]	Attachment size
$M_A$	[Nm]	Tightening torque of the clamping screws
Z		Number of clamping screws
S		Size of the clamping screws
$n_{max}$	[min <sup>-1</sup> ]	Permitted rotational frequency
$p_N$	[N/mm <sup>2</sup> ]	Average pressure to the hub
I	[kgm <sup>2</sup> ]	Moment of inertia

## Design of the shrink disc

	Disc painted with washers
$d \geq 200$	Cone of bush not slit

Dimensions H & e in unlocked position

min. yield strength Rp0,2	N/mm <sup>2</sup>
solid shaft	350
Hub	450

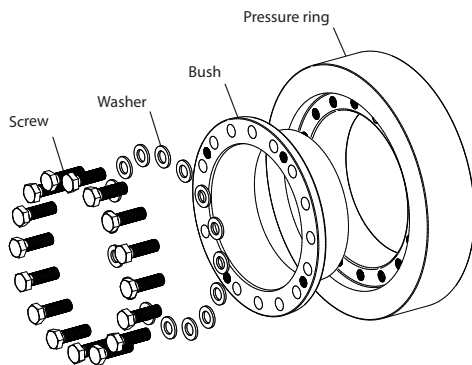

Ordering information: TAS 3393 - d (z.B.: TAS 3393-390 ... further sizes on request)



# 3393 Heavy-Range (strengthened)

<b>d</b> mm	<b>d<sub>w</sub></b> mm	<b>M<sub>max</sub></b> Nm	<b>D</b> mm	<b>l</b> mm	<b>e</b> mm	<b>H</b> mm	<b>A</b> mm	<b>d<sub>1</sub></b> mm	<b>M<sub>A</sub></b> Nm	<b>Z</b> Stk	<b>S</b>	<b>DIN</b>	<b>Klasse</b>	<b>n<sub>max</sub></b> min <sup>-1</sup>	<b>p<sub>N</sub></b> N/mm <sup>2</sup>	<b>I</b> kgm <sup>2</sup>	<b>Weight</b> kg
140	100	30.000	240	60	10	70	174	144	290	8	M16x040	933	12.9	2387	249	0,134464	15,5
	105	34.000															
	115	43.000															
155	110	45.000	263	66	11	77	194	160	290	9	M16x045	933	12.9	2179	273	0,211805	20
	115	50.000															
	125	61.000															
165	120	64.000	290	72	11	83	200	169	290	12	M16x045	933	12.9	1976	291	0,347305	28
	125	70.000															
	135	84.000															
175	130	74.000	300	72	12	84	210	179	290	12	M16x045	933	12.9	1910	287	0,392860	29
	135	80.000															
	145	95.000															
185	140	106.000	320	92	13	105	232	189	570	12	M20x050	933	12.9	1790	275	0,650897	40,5
	145	115.000															
	155	135.000															
200	150	127.000	340	92	14	106	246	204	570	12	M20x060	933	12.9	1685	289	0,822032	44,5
	155	137.000															
	165	158.000															
220	160	163.000	370	117	14	131	266	224	570	15	M20x060	933	12.9	1549	260	1,45	65,5
	170	176.000															
	180	215.000															
240	170	209.000	405	122	15	137	286	244	570	16	M20x060	933	12.9	1415	280	2,18	82
	180	238.000															
	200	303.000															
260	190	288.000	430	136	19	155	306	265	570	18	M20x070	933	12.9	1332	276	3,05	100
	200	325.000															
	220	404.000															
280	210	361.000	460	148	20	168	334	285	900	16	M24x70	933	12.9	1246	257	4,32	126
	220	402.000															
	240	491.000															
300	220	465.000	485	152	22	174	354	305	900	16	M24x80	933	12.9	1181	265	5,43	141
	230	513.000															
	250	563.000															
320	240	510.000	520	160	22	182	374	325	900	18	M24x80	933	12.9	1102	255	7,58	171
	250	560.000															
	270	669.000															
340	250	664.000	570	176	24	200	404	345	1310	18	M27x080	933	12.9	1005	276	12,33	234
	260	726.000															
	280	859.000															
350	270	700.000	580	180	23	203	414	361	1310	18	M27x080	933	12.9	988	244	13,35	243
	280	760.000															
	290	820.000															

# 3393 Heavy-Range (strengthened)

<b>d</b> mm	<b>d<sub>w</sub></b> mm	<b>M<sub>max</sub></b> Nm	<b>D</b> mm	<b>l</b> mm	<b>e</b> mm	<b>H</b> mm	<b>A</b> mm	<b>d<sub>1</sub></b> mm	<b>M<sub>A</sub></b> Nm	<b>Z</b> Stk	<b>S</b>	<b>DIN</b>	<b>Klasse</b>	<b>n<sub>max</sub></b> min <sup>-1</sup>	<b>p<sub>N</sub></b> N/mm <sup>2</sup>	<b>I</b> kgm <sup>2</sup>	<b>Weight</b> kg
<b>360</b>	270	763.000	590	180	24	204	424	365	1310	18	M27x090	933	12.9	971	266	14,20	249
	280	829.000															
	300	969.000															
<b>390</b>	290	975.000	650	190	27	217	456	398	1310	20	M27x090	933	12.9	882	278	22,30	325
	300	1.050.000															
	320	1.215.000															
<b>420</b>	320	1.300.000	690	214	29	243	486	428	1310	21	M27x100	933	12.9	831	269	31,59	404
	330	1.390.000															
	350	1.590.000															
<b>440</b>	340	1.590.000	750	225	28	253	514	448	1800	21	M30x100	933	12.9	764	274	47,37	530
	350	1.695.000															
	370	1.915.000															
<b>460</b>	360	1.750.000	760	226	30	256	534	468	1800	21	M30x100	933	12.9	754	268	49,27	520
	370	1.860.000															
	390	2.090.000															
<b>480</b>	380	2.110.000	800	246	30	276	552	488	1800	21	M30x100	933	12.9	717	265	66,17	640
	390	2.230.000															
	410	2.490.000															
<b>500</b>	400	2.555.000	850	246	32	278	572	508	1800	24	M30x100	933	12.9	674	287	85,28	740
	410	2.700.000															
	430	2.995.000															
<b>530</b>	430	3.110.000	890	280	34	314	616	538	2600	21	M33x110	933	12.9	644	266	116,23	900
	440	3.275.000															
	460	3.610.000															
<b>560</b>	450	3.455.000	940	280	35	315	646	568	2600	24	M33x110	933	12.9	610	269	144,60	1000
	460	3.625.000															
	480	3.980.000															
<b>590</b>	470	4.030.000	980	296	37	333	666	600	2600	24	M33x120	933	12.9	585	273	179,40	1150
	480	4.220.000															
	500	4.615.000															
<b>620</b>	500	5.045.000	1020	330	39	369	706	630	2600	27	M33x120	933	12.9	562	268	233,17	1370
	520	5.265.000															
	540	5.965.000															
<b>660</b>	530	5.835.000	1090	334	42	376	750	670	3300	27	M36x130	933	12.9	526	275	308,48	1570
	550	6.080.000															
	570	6.835.000															
<b>700</b>	560	6.490.000	1160	334	43	377	802	710	3300	27	M36x130	933	12.9	494	273	396,52	1810
	580	6.740.000															
	600	7.530.000															
<b>750</b>	600	7.675.000	1220	370	44	414	852	760	3300	30	M36x130	933	12.9	470	254	530,79	2140
	620	8.235.000															
	650	9.120.000															

# 3393 Heavy-Range (strengthened)

<b>d</b> mm	<b>d<sub>w</sub></b> mm	<b>M<sub>max</sub></b> Nm	<b>D</b> mm	<b>l</b> mm	<b>e</b> mm	<b>H</b> mm	<b>A</b> mm	<b>d<sub>1</sub></b> mm	<b>M<sub>A</sub></b> Nm	<b>Z</b> Stk	<b>S</b>	<b>DIN</b>	<b>Klasse</b>	<b>n<sub>max</sub></b> min <sup>-1</sup>	<b>p<sub>N</sub></b> N/mm <sup>2</sup>	<b>I</b> kgm <sup>2</sup>	<b>Weight</b> kg
<b>800</b>	640	9.090.000	1350	360	46	406	920	810	3300	35	M36x140	933	12.9	425	272	792,06	2651
	660	9.710.000															
	700	11.025.000															
<b>850</b>	650	8.925.000	1440	380	44	424	950	860	3300	36	M36x140	933	12.9	398	247	1084,37	3271
	700	10.475.000															
	730	11.470.000															
<b>900</b>	700	10.260.000	1470	400	47	447	1010	912	3300	38	M36x140	933	12.9	390	232	1212,30	3370
	730	11.235.000															
	760	12.255.000															
<b>950</b>	750	12.150.000	1520	430	50	480	1050	970	3300	44	M36x150	933	12.9	377	222	1468,34	3805
	780	13.220.000															
	820	14.730.000															
	800	14.300.000	1550	460	56	486	1100	1020	3300	44	M36x160	933	12.9	370	214	1549,03	3820
	830	15.500.000															
	860	16.700.000															
	850	16.200.000	1580	480	60	540	1160	1070	3300	44	M36x160	933	12.9	363	205	1816,86	4050
	880	17.400.000															
	920	19.200.000															





Für die stärksten Anwendungen

# DIE TAS SCHÄFER BLACK EDITION IST DA!

## TAS 3381/ TAS 3393

- 2 teilige Schrumpfscheibe
- Für höhere Drehmomente
- Einfache Handhabung
- Designoptimiert
- Gewichtsreduziert
- Optimierte Abmessungen
- Für niedrige Anwendungstemperaturen

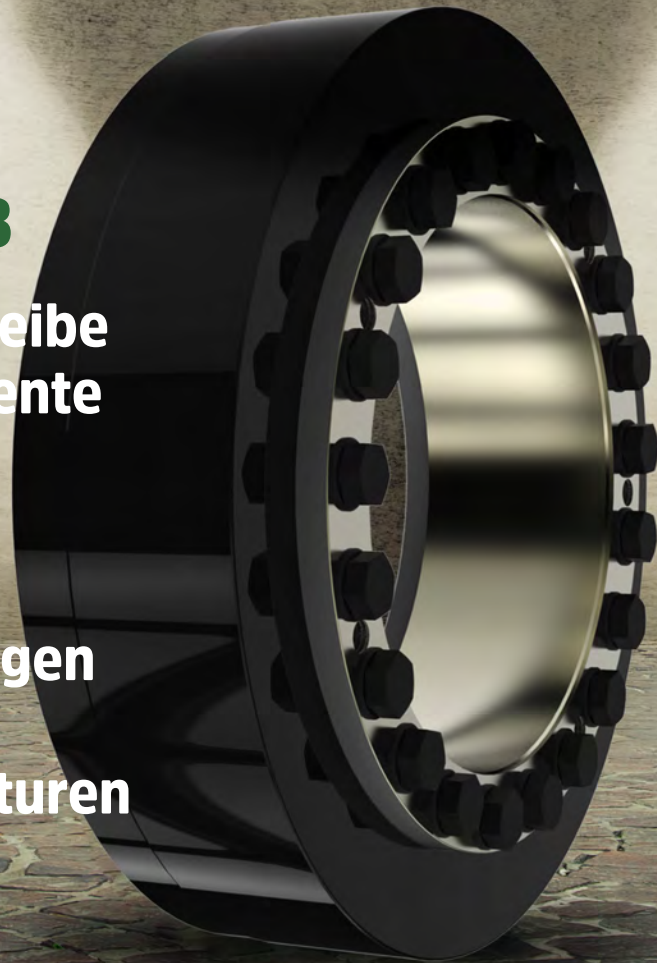

**TAS Schäfer GmbH**

Osterfeldstrasse 75  
58300 Wetter

Telefon: +49 (0) 2335 9781-0

Fax: +49 (0) 2335 72956

[www.tas-schaefer.de](http://www.tas-schaefer.de)  
[info@tas-schaefer.de](mailto:info@tas-schaefer.de)







**TAS**  
SCHÄFER

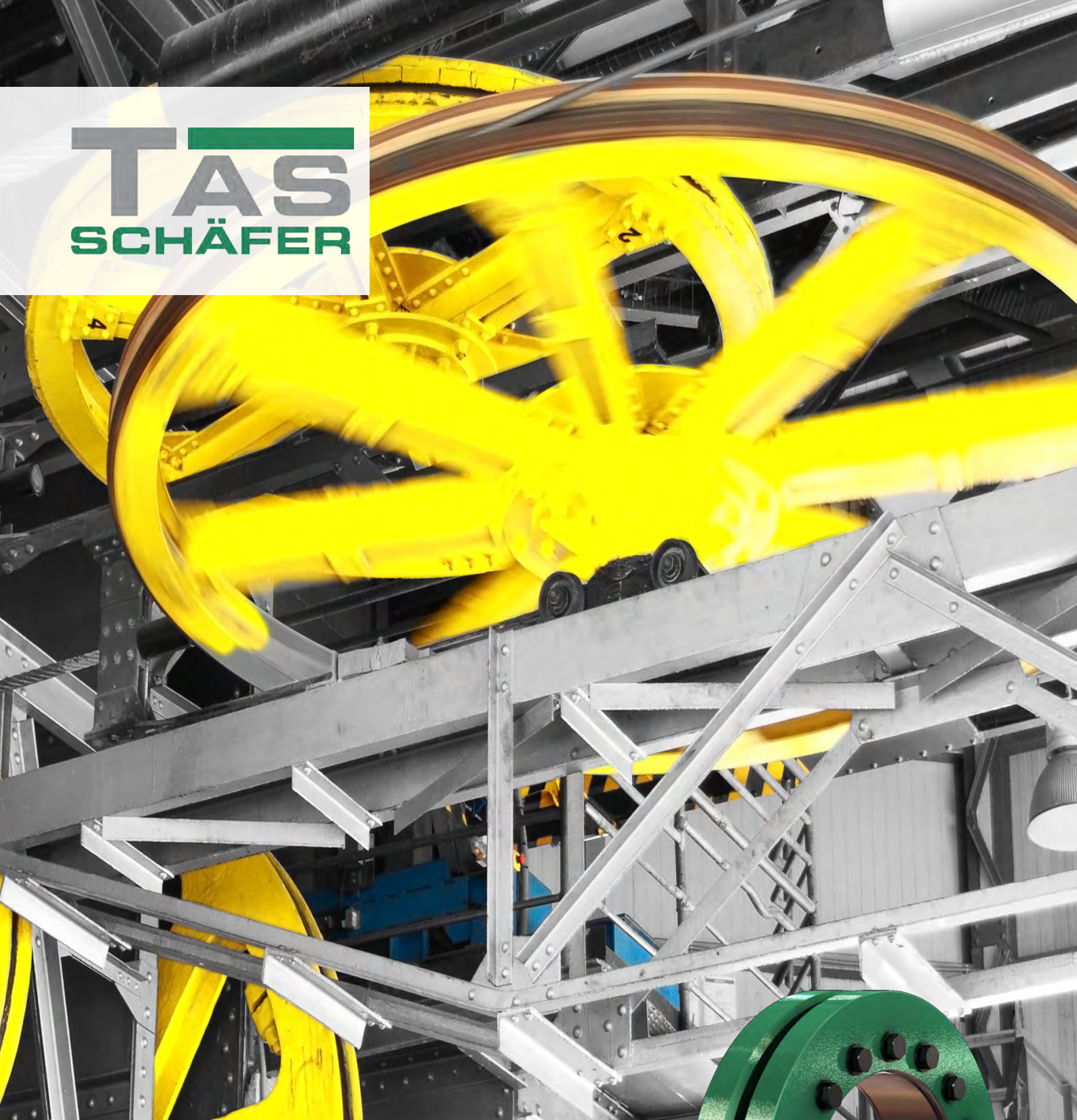

# Shrink Discs 3-part

External clamping devices



# Description of function

## Three part shrink disc of the types TAS 30.. & TAS 52..

The main function of a shrink disc is the safe connection of a shaft with a hub by means of friction. For example, between a drive shaft and a transmission hollow shaft. The shrink disc generates a backlash-free connection by pressing the hub onto the shaft. This connection is mainly used to transmit torque.

The shrink disc only provides the required forces, and transfers no forces or moments between shaft and hub by itself. Therefore, the force flow does not pass through it.

It is installed by sliding the shrink disc onto the hollow shaft and the subsequent tightening of the screws. By using conical surfaces the inner diameter reduces and the radial pressure is built up. The 30xx range of shrink discs are not self-locking. The clamping forces are provided and controlled through the screws.

This allows the direct compensation of the clearance between the shaft and hub, without an overload that may occur on path controlled shrink discs, due to small or over sized clearance.

The supplied shrink discs are ready for installation.

To achieve proper operation with a sufficiently high coefficient of friction, the contact surfaces between shaft and hub must be dry, clean and free of grease. The functional surfaces of the shrink disc, the thread surfaces and head rests of the screws, are equipped at the factory with lubricant. Molykote G-Rapid Plus or comparable must be used as a lubricant. The contact surfaces between the hub and inner ring must be provided with grease or oil before installation.

### Product data

A detailed installation manual is available on our Homepage.

### Data sheets

- Contact us if a data sheet for an individual product is required.

We provide CAD data for our products in various formats please contact us:

**Rolf Gertner**  
rolf.gertner@tas-schaefer.de

or

**Mike Kemper**  
mike.kemper@tas-schaefer.de

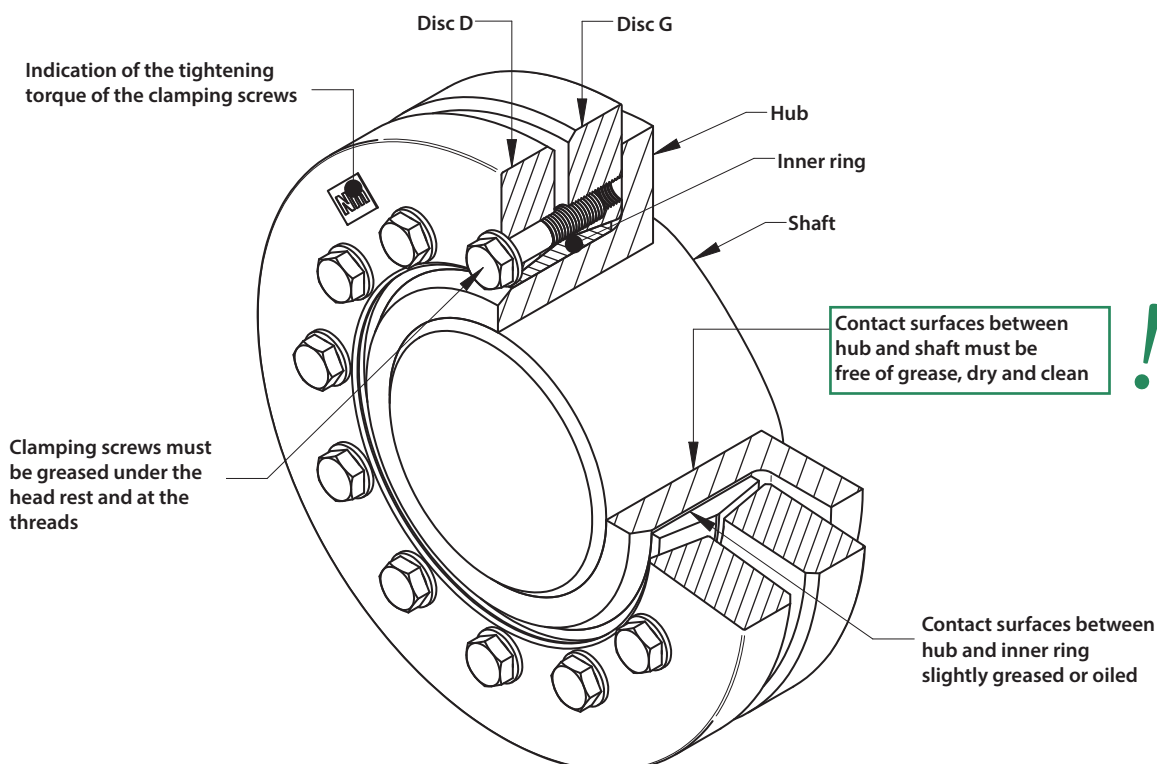



# Basics - Design

## Clamping length for shrink discs

The clamping length  $l$  of the shrink disk at the junction  $l_k$  (between shaft and hub), should be chosen to be somewhat wider to minimize the stress concentration at this point. An excessively wide connection increases the tendency to fretting corrosion, because the pressure decreases outward. The pressure is distributed approximately at an angle between  $15^\circ - 20^\circ$  through the hub. This is largely dependent on the hub wall thickness and stiffness of the shaft. A good approximation can be made from the following equation:

Clamping length of the contact area:  

$$l_k = 0,316(d - d_w) + l$$

The cylindrical surfaces should be located symmetrically under the shrink disc! With a slightly different clamping length the transmissible torque  $M$  will not change, because a smaller contact surface results in a higher pressure - also a larger contact surface causes lower pressure.

## Tightening torque of the clamping screws

The given tightening torque values in the tables for the screws are based on a friction coefficient  $\mu_{ges} = 0,1$ . In principle, the specified tightening torque  $M_A$  can be reduced to  $M_{Agew}$  to reduce stresses in the components. This may be necessary for soft materials and bored shafts. The reduction of  $M_A$  also reduced the pressure  $p_N$  and transmissible torque  $M$ . The ratio is approximately proportional and can be calculated according to:

$$M = \frac{M_{Agew}}{M_A} M \quad \text{also} \quad p_N = \frac{M_{Agew}}{M_A} p_N$$

The tightening torques can not be reduced arbitrary, therefore apply the following limits:

$$M_{Agew} \geq \begin{pmatrix} \text{Class 8.8 : } 0,85 M_A \\ \text{Class 10.9 : } 0,70 M_A \\ \text{Class 12.9 : } 0,60 M_A \end{pmatrix} \leq M_A$$

A further reduction requires additional screw locks!

## Tolerances and surfaces

The values found in the product data based on surface quality and tolerances according to the table below. These values are given as recommendations.

Higher values for the surface roughness reduces the transmissible torque and promote unwanted settling. Larger clearance also reduces the transmissible torque and heightened tensions in the hub.

In the case of significantly different values, please contact us!

Tolerance for the outer diameter hub - f7!

Recommended tolerances and surface roughness				
>	≤	FS <sub>max</sub> mm	Clea Hub/Shaft	Rz µm
9	18	0,022	H6/h6	10
18	30	0,026	H6/h6	10
30	50	0,032	H6/h6	10
50	80	0,049	H7/h6	10
80	120	0,057	H7/h6	16
120	150	0,065	H7/h6	16
150	180	0,079	H7/g6	16
180	250	0,090	H7/g6	16
250	315	0,101	H7/g6	16
315	400	0,111	H7/g6	16
400	500	0,123	H7/g6	25
500	630	0,136	H7/g6	25
630	800	0,154	H7/g6	25
800	1000	0,172	H7/g6	25

# Basic - Calculation

The calculation of the values, given in the catalogue, are based on the following assumptions and simplifications:

## Transmissible torque

A shrink disc connection is capable of transmitting torque, bending moment and axial force. Alternatively, the transmissible torque  $M_{max}$  is specified in the product data. If such loads occur simultaneously then they must be added vectorially to the resultant moment  $M_{res}$ .

The formula below applies to the resulting moment:

$$M_{res} \leq M_{max}$$

At different load cases, these are individually checked against  $M_{max}$  !

$M_{res}$  is determined for combined loads as follows:

$$M_{res} = \sqrt{M_T^2 + 2M_B^2 + (F_{AX} \frac{d_W}{2})^2}$$

with  $M_B \leq 0,3 M_{max}$   
as the limit\* for the bending moment

\*In principle, the maximum bending moment corresponds to the maximum transmittable torque. The limitation to  $0,3 M_{max}$  is due to the change of the surface pressure at the edges of the connection. (see also „Bending moment“)

This results in the following relationships:

### Torque only:

The maximum torque is equivalent to  $M_{max}$  .

### Bending moment only:

The maximum bending moment corresponds to  $0,3 M_{max}$  .

### Axial force only:

The maximum axial force is

$$M_{max} \frac{2}{d_W} .$$

A different equation applies for very small shrink discs (3073):

$$M_B \leq 0,2 M_{max}$$

Depending on the application, additional safety factors need to be considered for the individual loads!

## Calculation of transmissible torques and forces

The catalogue data relates to specific shaft diameters which we recommend using. If the shaft diameter is between two sizes, the larger shrink disc should be selected. A deviation is possible within certain limits but the predetermined tolerances and surface roughness should be considered.

The shaft diameter and transmissible torque behave approximately proportional to each other. The transmissible torque increases with greater shaft diameter and vice versa. In contrast, the transmissible axial force changes only slightly. This is not due to the shaft diameter but because of the change in stiffness of the hub when the inner diameter changes.

Within certain limits, the changes can be linearly approximated. Information about the range of the respective shaft diameter can be found in the product data. The determination of the deviating values is explained below. Please contact us if the shaft diameter must be outside the indicated range. The formula below calculates the torque for specific shaft diameters:

$$M = M_{max(Catalog)} \left( \frac{d_{W(target)}}{d_{W(Catalog)}} \right)^2$$

The corresponding axial force which is transmitted instead of the torque, results as follows:

$$F_{ax} = M \frac{2}{d_{W(table)}}$$

## Radial force

Radial forces cause a change in pressure at the contact surface. In the force direction, the pressure increases on the one side and is reduced accordingly on the other side. This depends on the amount of radial force and the rigidity of the parts.

The following equation can be used to approximate the pressure change:

$$\Delta p_W = 0,75 \frac{F_{AX}}{d_W l_K}$$

The modified pressures  $p_{Wmin, max}$  results from the following equation:

$$p_{Wmin, max} = p_W \pm \Delta p_W$$

The minimum pressure  $p_{Wmin}$  should be at least  $50 \text{ N/mm}^2$  to avoid gap corrosion. In addition, the material must be designed for a maximum pressure  $p_{Wmax}$  .

# Basics - Calculation

The calculation of the values, given in the catalogue, are based on the following assumptions and simplifications:

## Bending moment

Here the situation is similar to the radial forces. However the pressure is greatest at the ends of the connection in this case. Again, the amount and stiffness are important. This leads to the following approximation:

$$\Delta p_w = 4,5 \frac{M_B}{d_w l_k^2}$$

As before, the modified pressures results from:

$$p_{wmin, max} = p_w \pm \Delta p_w$$

The conditions for minimum and maximum pressure are the same as before. It should be noted that there could be a change in pressure due to radial force!

## Shaft and hub calculation

The catalogue contains information on the generated surface pressure for each shrink disc. The hub will be deformed due to the applied radial force. In addition to the clearance between shaft and hub, shaft stiffness and surface finish should be considered. For solid shafts the flexibility can be ignored, but with hollow shafts (see „Bore in the shaft (hollow shaft)“) there is greater deformation and thus greater stresses in the components. This must be considered in addition to other loads.

The stresses in the hub can be determined by various hypotheses, such as GEH. We will not make a presentation and analyse results at this point because we would only be able to cover a very limited range of static applications. Various calculation methods for different cases can be found in engineering literature or using specialised software. However, for complex geometry often only a calculation by FEM gives reliable results.

The information on the minimum yield strength of shafts and hubs are suggested recommendations,

based on typical values for such applications. They are provided as guidelines and are not a replacement for a proper calculation for a given application!

## Notch effect

Generally there is a notch effect on the components, caused by the radial pressure of the shrink disc. This depends mainly on the applied pressure. The notch effect is generally higher on the hub than on the shaft, because here the inner ring of the shrink disc is directly pressed onto the hub, while the stresses are distributed through the hub before reaching the shaft. The notch factors range from 2,5 to 3,5 for the hub and it is between 1,5 and 2 for the shaft. This can be mitigated by suitable design features, such as relief notches.

Some standards provide the possibility of a notch factor to be determined by a fit pairing for a shrink-connection. A similar method also can be used for a shrink disc connection. To this end an oversize can be calculated from the applied surface pressures. As a result, a matching fit pair can be determined and thus a resultant notch factor found.

## Bore in the shaft (hollow shaft)

A large bore  $d_B$  in the shaft or the use of a hollow shaft, reduces the stiffness of this component against radial pressure. This leads to a decrease in pressure  $p_w$ , a reduced transmissible torque  $M$ , a contraction  $\Delta d_B$  within the shaft and an increase of stresses in these components. Basically, a bore should not be greater than  $0,3 d_w$ .





# 3073 Mini-Range

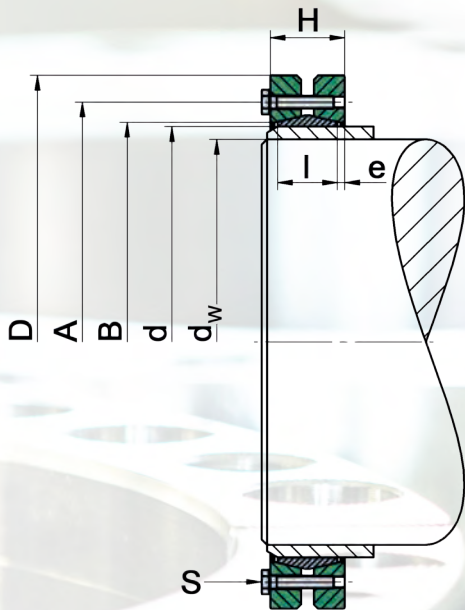

## Used symbols

d	[mm]	Nominal diameter of the shrink disc
d <sub>w</sub>	[mm]	Shaft diameter
M <sub>max</sub>	[Nm]	Maximal transmittable torque
D	[mm]	Outer diameter
l	[mm]	Length of the inner ring
e	[mm]	Excess length
H	[mm]	Width of the shrink disc
A	[mm]	Pitch circle diameter
B	[mm]	Attachment size
M <sub>A</sub>	[Nm]	Tightening torque of the clamping screws
Z		Number of clamping screws
S		Size of the clamping screws
n <sub>max</sub>	[min <sup>-1</sup> ]	Permitted rotational frequency
p <sub>N</sub>	[N/mm <sup>2</sup> ]	Average Pressure to the hub
I	[kgm <sup>2</sup> ]	Moment of inertia

## Design of the shrink disc

- Discs galvanized
- without washers
- Dimensions H & e in unlocked position

min. yield strength Rp0,2	N/mm <sup>2</sup>
Solid shaft	290
Hub	350

## Variation from the standard shaft diameter d<sub>w</sub>

> mm	≤ mm	minimal - mm	maximal + mm
20	60	-2	1
60	100	-2	2
100	160	-3	2
160	220	-4	2
220	300	-5	2

$$M = M_{max(Catalog)} \left( \frac{d_{W(target)}}{d_{W(Catalog)}} \right)^2$$

(see Basics - Calculation)

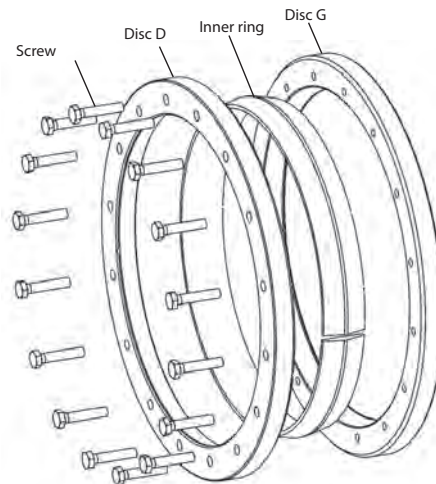

Ordering information: TAS 3073-d (Further sizes on request)

# 3073 Mini-Range

<b>d</b> mm	<b>d<sub>w</sub></b> mm	<b>M<sub>max</sub></b> Nm	<b>D</b> mm	<b>l</b> mm	<b>e</b> mm	<b>H</b> mm	<b>A</b> mm	<b>B</b> mm	<b>M<sub>A</sub></b> Nm	<b>Z</b> Stk	<b>S</b>	<b>DIN</b>	<b>Class</b>	<b>n<sub>max</sub></b> min <sup>-1</sup>	<b>p<sub>N</sub></b> N/mm <sup>2</sup>	<b>I</b> kgm <sup>2</sup>	<b>Weight</b> kg
20	18	78	47	10	2	14	34	22	3	4	M 5 x 14	933	8.8	12100	155	0,0000424	0,13
24	20	80	52	10	2,5	15	39,5	26	3	5	M 5 x 14	933	8.8	11000	161	0,0000697	0,17
25	21	88	56	10	2,5	15	43	30	3	5	M 5 x 14	933	8.8	10200	155	0,0000940	0,20
28	24	110	56	10	2,5	15	43	30	3	5	M 5 x 14	933	8.8	10200	138	0,0000931	0,19
29	25	110	58	10	2,5	15	44,5	31,5	3	5	M 5 x 14	933	8.8	9800	133	0,0001051	0,20
30	26	120	58	10	2,5	15	44,5	31,5	3	5	M 5 x 14	933	8.8	9800	129	0,0001066	0,20
31	28	160	60	10	2,5	15	46	33	3	5	M 5 x 14	933	8.8	9500	125	0,0001197	0,21
35	30	180	64	10	2,5	15	50	36,5	3	6	M 5 x 14	933	8.8	8900	133	0,0001530	0,23
36	31	170	66	10	2,5	15	52	38,5	3	6	M 5 x 14	933	8.8	8600	129	0,0001766	0,25
37	32	180	66	10	2,5	15	52	38,5	3	6	M 5 x 14	933	8.8	8600	125	0,0001718	0,24
38	33	290	68	10	2,5	15	55	41,5	4	6	M 5 x 14	933	8.8	8400	163	0,0001972	0,26
40	35	310	68	10	2,5	15	55	41,5	4	6	M 5 x 14	933	8.8	8400	155	0,0001867	0,24
42	37	370	75	14	2,5	19	58	44	4	7	M 5 x 16	933	8.8	7600	123	0,0003510	0,38
46	40	460	80	14	2,5	19	63	49	4	8	M 5 x 16	933	8.8	7100	128	0,0004471	0,42
47	42	530	80	14	2,5	19	63	49	4	8	M 5 x 16	933	8.8	7100	125	0,0004412	0,41
48	43	550	86	14	2,5	19	68,5	53,5	4	8	M 5 x 16	933	8.8	6600	123	0,0006062	0,50
51	45	550	86	14	2,5	19	68,5	53,5	4	8	M 5 x 16	933	8.8	6600	115	0,0005873	0,47
55	49	710	91	14	2,5	19	73	59	4	9	M 5 x 16	933	8.8	6200	120	0,0007349	0,52
56	50	730	91	14	2,5	19	73	59	4	9	M 5 x 16	933	8.8	6200	118	0,0007278	0,51
58	52	710	93	14	2,5	19	74	60	4	9	M 5 x 16	933	8.8	6100	114	0,0007808	0,52
59	53	840	96	14	2,5	19	77	63	4	10	M 5 x 16	933	8.8	5900	125	0,0009047	0,57
60	54	860	96	14	2,5	19	77	63	4	10	M 5 x 16	933	8.8	5900	123	0,0008811	0,55
61	55	880	96	14	2,5	19	77	63	4	10	M 5 x 16	933	8.8	5900	121	0,0008732	0,54
65	59	970	100	14	2,5	19	82	68	4	10	M 5 x 16	933	8.8	5700	113	0,0010135	0,57
66	60	990	100	14	2,5	19	82	68	4	10	M 5 x 16	933	8.8	5700	112	0,0010049	0,56
69	63	1500	105	18	3	24	87	73	6	10	M 5 x 20	933	10.9	5400	117	0,0015194	0,77
70	65	1600	110	18	3	24	90	76	6	10	M 5 x 20	933	10.9	5200	115	0,0018912	0,89
72	67	1600	110	18	3	24	90	76	6	10	M 5 x 20	933	10.9	5200	112	0,0018364	0,85
73	68	1700	110	18	3	24	90	76	6	10	M 5 x 20	933	10.9	5200	110	0,0018300	0,84
75	70	1700	114	18	3	24	93	78,5	6	10	M 5 x 20	933	10.9	5000	107	0,0021181	0,91
78	70	1900	120	18	3	24	101	86	6	12	M 5 x 20	933	10.9	4700	124	0,0025605	1,0
81	73	2000	120	18	3	24	101	86	6	12	M 5 x 20	933	10.9	4700	119	0,0026201	1,0
83	75	2100	120	18	3	24	101	86	6	12	M 5 x 20	933	10.9	4700	116	0,0024748	0,93
85	77	2400	128	22	3	28	105	88,5	12	8	M 6 x 25	933	10.9	4400	103	0,0038365	1,3
88	80	2500	130	22	3	28	108	91,5	12	8	M 6 x 25	933	10.9	4400	99	0,0040046	1,3
94	85	2500	140	22	3	28	119	102,5	12	8	M 6 x 25	933	10.9	4000	93	0,0053318	1,5
95	86	2500	140	22	3	28	119	102,5	12	8	M 6 x 25	933	10.9	4000	92	0,0053672	1,5
98	90	2800	140	22	3	28	119	102,5	12	8	M 6 x 25	933	10.9	4000	89	0,0051107	1,4
99	91	2800	140	22	3	28	119	102,5	12	8	M 6 x 25	933	10.9	4000	88	0,0051452	1,4
100	92	2900	140	22	3	28	119	102,5	12	8	M 6 x 25	933	10.9	4000	87	0,0051800	1,4
103	95	3400	150	22	3	28	128	111,5	12	9	M 6 x 25	933	10.9	3800	95	0,0070357	1,7
104	96	3500	150	22	3	28	128	111,5	12	9	M 6 x 25	933	10.9	3800	95	0,0070796	1,7
105	97	3500	150	22	3	28	128	111,5	12	9	M 6 x 25	933	10.9	3800	94	0,0067050	1,6
108	100	3700	150	22	3	28	128	111,5	12	9	M 6 x 25	933	10.9	3800	91	0,0064058	1,5
112	104	3800	158	22	3	28	135	118,5	12	9	M 6 x 25	933	10.9	3600	88	0,0084393	1,8

# 3073 Mini-Range

<i>d</i> mm	<i>d<sub>w</sub></i> mm	<i>M<sub>max</sub></i> Nm	<i>D</i> mm	<i>l</i> mm	<i>e</i> mm	<i>H</i> mm	<i>A</i> mm	<i>B</i> mm	<i>M<sub>A</sub></i> Nm	<i>Z</i> Stk	<i>S</i>	<i>DIN</i>	<i>Class</i>	<i>n<sub>max</sub></i> min <sup>-1</sup>	<i>p<sub>N</sub></i> N/mm <sup>2</sup>	<i>I</i> kgm <sup>2</sup>	<i>Weight</i> kg
115	107	4000	158	22	3	28	135	118,5	12	9	M 6 x 25	933	10.9	3600	85	0,0081152	1,7
120	110	4300	164	25	3,5	32	141	123,5	12	10	M 6 x 25	933	10.9	3400	80	0,0103240	2,0
125	115	4600	169	25	3,5	32	146	128,5	12	10	M 6 x 25	933	10.9	3300	77	0,0115988	2,1
130	120	6000	179	25	3,5	32	156	138,5	12	12	M 6 x 25	933	10.9	3200	89	0,0146823	2,4
135	125	6200	179	25	3,5	32	156	138,5	12	12	M 6 x 25	933	10.9	3200	85	0,0138232	2,2
138	128	6400	182	25	3,5	32	161	143,5	12	12	M 6 x 25	933	10.9	3100	84	0,0149983	2,3
140	130	6500	182	25	3,5	32	161	143,5	12	12	M 6 x 25	933	10.9	3100	82	0,0144991	2,2
145	135	6800	194	25	3,5	32	171	153,5	12	12	M 6 x 25	933	10.9	2900	80	0,0197981	2,7
150	140	7100	194	25	3,5	32	171	153,5	12	12	M 6 x 25	933	10.9	2900	77	0,0180408	2,4
160	150	7700	204	25	3,5	32	181	163,5	12	12	M 6 x 25	933	10.9	2800	72	0,0218452	2,6
166	156	7900	210	25	3,5	32	187	169,5	12	12	M 6 x 25	933	10.9	2700	69	0,0241839	2,7
167	157	9500	214	25	3,5	32	191	173,5	12	14	M 6 x 25	933	10.9	2600	81	0,0267108	2,9
170	160	9700	214	25	3,5	32	191	173,5	12	14	M 6 x 25	933	10.9	2600	79	0,0252099	2,7
173	163	9900	220	25	3,5	32	196	178,5	12	14	M 6 x 25	933	10.9	2600	78	0,0293734	3,0
175	165	10100	220	25	3,5	32	196	178,5	12	14	M 6 x 25	933	10.9	2600	77	0,0286466	2,9
180	170	10400	225	25	3,5	32	201	183,5	12	14	M 6 x 25	933	10.9	2500	75	0,0300966	2,9
185	175	11600	230	25	3,5	32	206	188,5	12	15	M 6 x 25	933	10.9	2400	78	0,0326719	3,0
192	180	11500	240	28	3,5	35	220	200,5	12	15	M 6 x 30	933	10.9	2300	67	0,0436896	3,7
195	183	11600	240	28	3,5	35	220	200,5	12	15	M 6 x 30	933	10.9	2300	66	0,0418359	3,5
198	186	12700	250	28	3,5	35	225	206	12	16	M 6 x 30	933	10.9	2200	69	0,0533946	4,2
202	190	13100	250	28	3,5	35	225	206	12	16	M 6 x 30	933	10.9	2200	68	0,0503607	3,9
212	200	13900	260	28	3,5	35	235	216	12	16	M 6 x 30	933	10.9	2200	65	0,0576788	4,1
214	202	16000	270	28	3,5	35	245	226	12	18	M 6 x 30	933	10.9	2100	72	0,0727013	4,9
215	203	16100	270	28	3,5	35	245	226	12	18	M 6 x 30	933	10.9	2100	72	0,0714750	4,8
220	208	16600	270	28	3,5	35	245	226	12	18	M 6 x 30	933	10.9	2100	70	0,0667150	4,4
222	210	16700	270	28	3,5	35	245	226	12	18	M 6 x 30	933	10.9	2100	70	0,0641466	4,2
230	218	17500	280	28	3,5	35	255	236	12	18	M 6 x 30	933	10.9	2000	67	0,0754975	4,6
232	220	17700	280	28	3,5	35	255	236	12	18	M 6 x 30	933	10.9	2000	67	0,0727232	4,4
235	223	17900	290	28	3,5	35	265	246	12	18	M 6 x 30	933	10.9	1900	66	0,0905613	5,2
236	224	18000	290	28	3,5	35	265	246	12	18	M 6 x 30	933	10.9	1900	65	0,0891199	5,1
242	230	18600	290	28	3,5	35	265	246	12	18	M 6 x 30	933	10.9	1900	64	0,0820318	4,6
252	240	19500	300	28	3,5	35	276	256	12	18	M 6 x 30	933	10.9	1900	61	0,0901836	4,7
257	245	22400	310	28	3,5	35	286	266	12	20	M 6 x 30	933	10.9	1800	67	0,1094506	5,4
262	250	22900	310	28	3,5	35	286	266	12	20	M 6 x 30	933	10.9	1800	66	0,1009057	4,9
266	254	25600	325	28	3,5	35	291	271	12	22	M 6 x 30	933	10.9	1700	71	0,1366953	6,2
278	265	28900	352	32	4	40	304	284	12	24	M 6 x 30	933	10.9	1600	65	0,2389108	9,5
280	267	29200	352	32	4	40	304	286	12	24	M 6 x 30	933	10.9	1600	64	0,2351784	9,3
298	283	30600	370	32	4	40	322	302	12	24	M 6 x 30	933	10.9	1500	60	0,2764874	9,8
300	285	30900	370	32	4	40	324	304	12	24	M 6 x 30	933	10.9	1500	60	0,2722800	9,6
310	285	31000	385	32	4	40	334	314	12	26	M 6 x 30	933	10.9	1400	63	0,3359469	11
335	300	51800	410	34	5	44	365	340	30	20	M 8 x 35	933	10.9	1300	88	0,3854469	11
350	320	23700	405	28	4,5	37	374,7	357	18	15	M 8 x 30	933	10.9	1400	46	0,2650356	7,4
360	330	71400	450	40	5	50	390	366	30	24	M 8 x 40	933	10.9	1200	83	0,7472250	18
370	340	53500	455	42	5	52	400	376	30	18	M 8 x 40	933	10.9	1200	58	0,7738312	18
380	340	52000	455	32	6	44	410	386	30	18	M 8 x 30	933	10.9	1200	74	0,6149938	14



# 3051 Light-Range

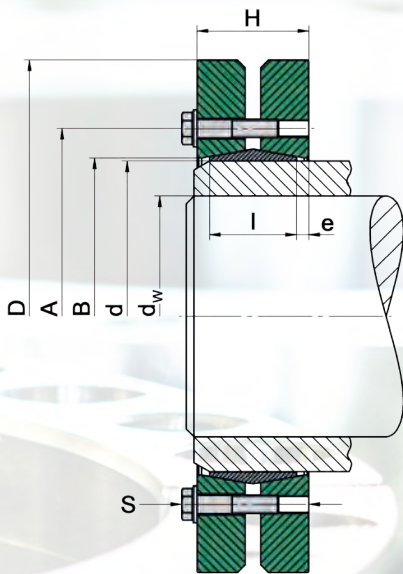

## Used symbols

d	[mm]	Nominal diameter of the shrink disc
d <sub>w</sub>	[mm]	Shaft diameter
M <sub>max</sub>	[Nm]	Maximal transmittable torque
D	[mm]	Outer diameter
l	[mm]	Length of the inner ring
e	[mm]	Excess length
H	[mm]	Width of the shrink disc
A	[mm]	Pitch circle diameter
B	[mm]	Attachment size
M <sub>A</sub>	[Nm]	Tightening torque of the clamping screws
Z		Number of clamping screws
S		Size of the clamping screws
n <sub>max</sub>	[min <sup>-1</sup> ]	Permitted rotational frequency
p <sub>N</sub>	[N/mm <sup>2</sup> ]	Average pressure to the hub
I	[kgm <sup>2</sup> ]	Moment of inertia

## Design of the shrink disc

d < 140	Discs galvanized without washers
d ≥ 140	Discs painted with washers

Dimensions H & e in unlocked position

Hexagon head bolts are used as standard. Upon request we provide all sized shrink discs with hexagon socket head bolts (Inbus). (See ordering information)

min. yield strength Rp0,2	N/mm <sup>2</sup>
Solid shaft	290
Hub	350

Variation from the standard shaft diameter d <sub>w</sub>			
> mm	≤ mm	minimal - mm	maximal + mm
100	170	-5	5
170	230	-10	5
230	320	-10	10
320	480	-15	10
480	510	-20	10

$$M = M_{max(Catalog)} \left( \frac{d_w(target)}{d_w(Catalog)} \right)^2$$

(see Basics - Calculation)

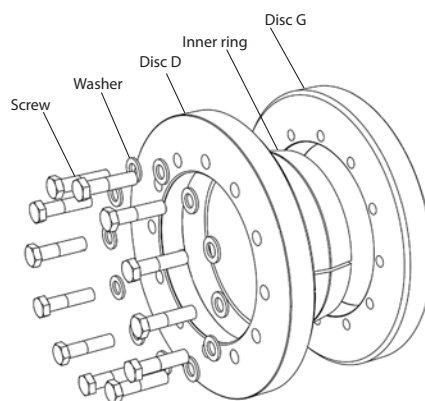

Ordering information: TAS 3051 - d (z.B. 3051-200)  
with Inbus: TAS 3051 - d - Inbus (z.B. 3051-200-Inbus)

# 3051 Light-Range

<i>d</i> mm	<i>d<sub>w</sub></i> mm	<i>M<sub>max</sub></i> Nm	<i>D</i> mm	<i>l</i> mm	<i>e</i> mm	<i>H</i> mm	<i>A</i> mm	<i>B</i> mm	<i>M<sub>A</sub></i> Nm	<i>Z</i> Stk	<i>S</i>	<i>DIN</i>	<i>Class</i>	<i>n<sub>max</sub></i> min <sup>-1</sup>	<i>p<sub>N</sub></i> N/mm <sup>2</sup>	<i>I</i> kgm <sup>2</sup>	<i>Weight</i> kg
120	100	11900	185	39	6	51	158	129	59	8	M 10 x 40	931	10.9	3000	169	0,0328219	5,4
125	100	10900	185	39	6	51	158	129	59	8	M 10 x 40	931	10.9	3000	163	0,0317794	5,1
140	120	17300	220	39	6	51	175	144	59	9	M 10 x 40	931	10.9	2600	163	0,0663000	7,8
155	135	24800	245	39	6	51	192	159	59	11	M 10 x 40	931	10.9	2300	180	0,1029612	9,8
165	140	33100	260	46	8	62	210	169	100	10	M 12 x 50	931	10.9	2200	190	0,1540906	13
175	150	40000	275	46	8	62	220	179	100	11	M 12 x 50	931	10.9	2000	198	0,1859375	14
185	160	47000	295	46	8	62	225	189	100	12	M 12 x 50	931	10.9	1900	204	0,2576562	17
195	170	63400	315	56	8	72	237	199	100	15	M 12 x 55	931	10.9	1800	199	0,3945938	23
200	180	75700	330	56	8	72	242	204	100	16	M 12 x 55	931	10.9	1700	207	0,4839250	26
220	190	96500	345	66	9	84	265	224	250	10	M 16 x 70	931	10.9	1600	205	0,6487719	31
240	210	132000	370	66	9	84	290	244	250	12	M 16 x 70	931	10.9	1500	226	0,8509	35
260	230	172000	395	72	10	92	310	265	250	14	M 16 x 70	931	10.9	1400	223	1,2299	44
280	240	196000	425	84	10	104	333	285	250	16	M 16 x 75	931	10.9	1300	203	1,8779	58
300	260	243000	460	84	10	104	358	305	250	18	M 16 x 75	931	10.9	1200	213	2,6013	69
320	280	297000	495	84	11	106	378	325	250	20	M 16 x 75	931	10.9	1100	222	3,6914	85
340	300	339000	535	84	11	106	402	345	250	21	M 16 x 75	931	10.9	1000	219	5,0730	101
350	300	388000	545	100	11	122	413	360	490	16	M 20 x 90	931	10.9	1000	213	6,0831	116
360	310	404000	555	100	11	122	423	365	490	16	M 20 x 90	931	10.9	1000	207	6,5097	119
380	330	487000	585	112	12	136	442	387	490	18	M 20 x 100	931	10.9	970	197	8,94	147
390	340	564000	595	112	12	136	452	397	490	20	M 20 x 100	931	10.9	960	214	9,49	150
400	350	614000	615	112	12	136	462	407	490	21	M 20 x 100	931	10.9	930	219	10,90	162
420	360	643000	630	120	12	144	485	427	490	22	M 20 x 100	931	10.9	900	204	12,47	174
440	380	751000	660	120	12	144	505	447	490	24	M 20 x 100	931	10.9	860	212	15,02	191
460	400	934000	685	132	13	158	527	468	490	28	M 20 x 110	931	10.9	830	215	19,23	226
480	420	981000	715	132	13	158	547	488	490	28	M 20 x 110	931	10.9	800	206	22,80	246
500	440	1113000	750	132	13	158	567	508	490	30	M 20 x 110	931	10.9	760	212	27,83	274
530	470	1319000	800	150	12,5	175	600	540	490	33	M 20 x 120	931	10.9	710	194	39,83	346
560	500	1550000	850	150	12,5	175	630	570	490	36	M 20 x 120	931	10.9	670	200	51,03	394
590	530	1652000	870	150	12,5	175	676	602	490	36	M 20 x 130	931	10.9	650	190	54,42	394
620	560	1759000	880	150	12,5	175	686	624	490	36	M 20 x 130	931	10.9	650	181	54,46	376

# 3051 Half/Split (Light-Range)

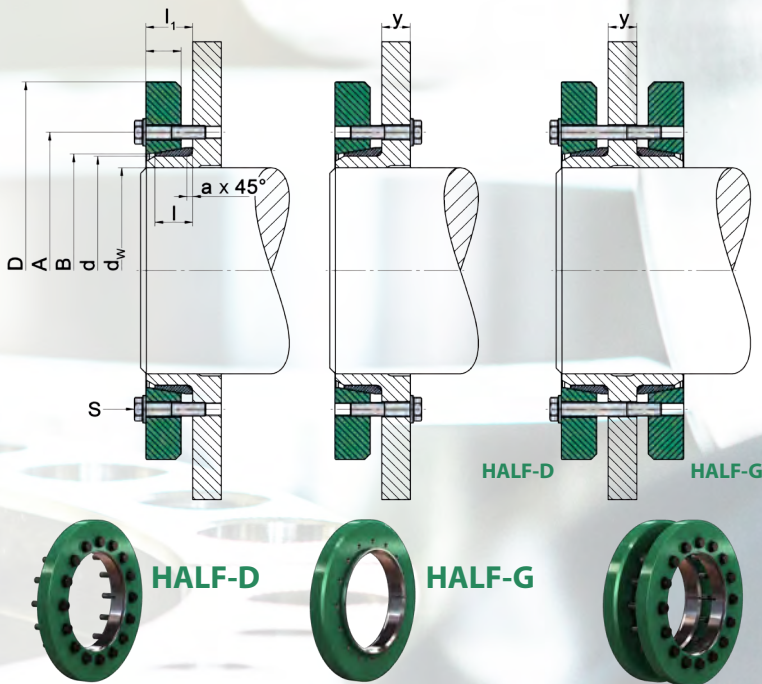

## Used symbols

d	[mm]	Nominal diameter of the shrink disc
$d_w$	[mm]	Shaft diameter
$M_{max}$	[Nm]	Maximal transmittable torque
D	[mm]	Outer diameter
l	[mm]	Length of the inner ring
e	[mm]	Excess length
H	[mm]	Width of the shrink disc
A	[mm]	Pitch circle diameter
B	[mm]	Attachment size
$M_A$	[Nm]	Tightening torque of the clamping screws
Z		Number of clamping screws
S		Size of the clamping screws
$n_{max}$	[min <sup>-1</sup> ]	Permitted rotational frequency
$p_N$	[N/mm <sup>2</sup> ]	Average pressure to the hub
I	[kgm <sup>2</sup> ]	Moment of inertia

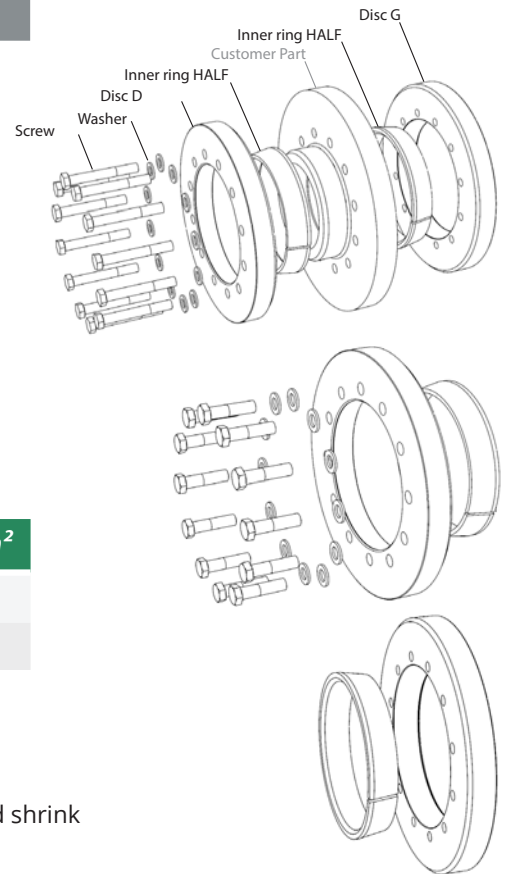

## Design of the shrink disc

d < 140	Discs galvanized without washers
d ≥ 140	Discs painted with washers

min. yield strength Rp0,2	N/mm <sup>2</sup>
Solid shaft	290
Hub	350

Dimensions H & e in unlocked position

Hexagon head bolts are used as standard. Upon request we provide all sized shrink discs with hexagon socket head bolts (Inbus). (See ordering information)

Deviation from the standard shaft diameter  $d_w$  see the table „3051 Light-Range“ and „Calculation of transmissible torques and forces“ Hexagon head bolts are used as standard. Upon request we provide all sized shrink discs with hexagon socket head bolts (Inbus). (See ordering information)

## For Typ in ordering information:

- GET means SPLIT
- HALB means HALF

Ordering information: TAS 3051Typ - d - y (for Example: TAS 3051GET-200-Y60 or TAS 3051HALB-G-200-Y30 or TAS 3051HALB-D-200) with Inbus: TAS 3051Typ - d - y - Inbus (z.B.: TAS 3051GET-200-Y60-Inbus e.t.c.)



# 3051 Half/Split (Light-Range)

**Please note:**

All values refer to shrink disk design **HALF!** Please provide us the dimension of „y“ or the length of screws. Otherwise we can not provide appropriate screws! (see ordering information)

**Applies to shrink disc design HALF-G:**

- The required screw length is:  
Screw length (3051 Light-Range) - l<sub>1</sub> + 2 a + y (rounded up to standard lengths)

**Applies to shrink disc design SPLIT:**

- The design consists of 1x HALF-D + 1x HALF-G
- Delivery is possible with or without screws
- Maximum transmittable torque:  $M_{ges} = 2 M_{max}$
- The required screw length: Screw length (3051 Light-Range) + 2 a + y (rounded up to standard lengths)

											HALF-D only							
d	d <sub>w</sub>	M <sub>max</sub>	D	l	a	l <sub>1</sub>	A	B	M <sub>A</sub>	Z	d <sub>B</sub>	S	DIN	Class	n <sub>max</sub>	p <sub>N</sub>	I	Weight
mm	mm	Nm	mm	mm	mm	mm	mm	mm	Nm	Stk	mm				min <sup>-1</sup>	N/mm <sup>2</sup>	kgm <sup>2</sup>	kg
120	100	5900	185	24,5	5	30,5	158	129	59	8	11	M 10 x 40	931	10.9	3000	169	0,0164109	2,7
125	100	5400	185	24,5	5	30,5	158	129	59	8	11	M 10 x 40	931	10.9	3000	163	0,0155781	2,5
140	120	8600	220	24,5	5	30,5	175	144	59	9	11	M 10 x 40	931	10.9	2600	163	0,0331500	3,9
155	135	12400	245	24,5	5	30,5	192	159	59	11	11	M 10 x 40	931	10.9	2300	180	0,0514806	4,9
165	140	16500	260	28	5	36	210	169	100	10	13,5	M 12 x 50	931	10.9	2200	190	0,0770453	6,5
175	150	20000	275	28	5	36	220	179	100	11	13,5	M 12 x 50	931	10.9	2000	198	0,0956250	7,2
185	160	23500	295	28	5	36	225	189	100	12	13,5	M 12 x 50	931	10.9	1900	204	0,1288281	8,5
195	170	31700	315	33	5	41	237	199	100	15	13,5	M 12 x 55	931	10.9	1800	199	0,2058750	12
200	180	37800	330	33	5	41	242	204	100	16	13,5	M 12 x 55	931	10.9	1700	207	0,2419625	13
220	190	48200	345	41	6	50	265	224	250	10	17,5	M 16 x 70	931	10.9	1600	205	0,3348500	16
240	210	66100	370	41	6	50	290	244	250	12	17,5	M 16 x 70	931	10.9	1500	226	0,4376250	18
260	230	86200	395	44	6	54	310	265	250	14	17,5	M 16 x 70	931	10.9	1400	223	0,6149687	22
280	240	98100	425	52	8	62	333	285	250	16	17,5	M 16 x 80	931	10.9	1300	203	0,9390	29
300	260	121000	460	52	8	62	358	305	250	18	17,5	M 16 x 80	931	10.9	1200	213	1,3195	35
320	280	148000	495	52	8	63	378	325	250	20	17,5	M 16 x 80	931	10.9	1100	222	1,8240	42
340	300	169000	535	52	8	63	402	345	250	21	17,5	M 16 x 80	931	10.9	1000	219	2,5616	51
350	300	202000	545	60	10	71	413	360	490	16	22	M 20 x 90	931	10.9	1000	213	3,0416	58
360	310	202000	555	60	10	71	423	365	490	16	22	M 20 x 90	931	10.9	1000	207	3,2275	59
380	330	243000	585	69	12	81	442	387	490	18	22	M 20 x 100	931	10.9	970	197	4,4405	73
390	340	282000	595	69	12	81	452	397	490	20	22	M 20 x 100	931	10.9	960	214	4,7449	75
400	350	307000	615	69	12	81	462	407	490	21	22	M 20 x 100	931	10.9	930	219	5,4495	81
420	360	321000	630	73	12	85	485	427	490	22	22	M 20 x 110	931	10.9	900	204	6,2346	87
440	380	375000	660	73	12	85	505	447	490	24	22	M 20 x 110	931	10.9	860	212	7,5504	96
460	400	467000	685	79	14	92	527	468	490	28	22	M 20 x 120	931	10.9	830	215	9,6167	113
480	420	490000	715	81	14	94	547	488	490	28	22	M 20 x 120	931	10.9	800	206	11,40	123
500	440	556000	750	81	14	94	567	508	490	30	22	M 20 x 120	931	10.9	760	212	13,91	137
530	470	659000	800	90	14	102,5	600	540	490	33	22	M 20 x 120	931	10.9	710	194	19,91	173
560	500	775000	850	90	14	102,5	630	570	490	36	22	M 20 x 120	931	10.9	670	200	25,51	197
590	530	826000	870	90	14	102,5	676	602	490	36	22	M 20 x 130	931	10.9	650	190	27,21	197
620	560	879000	880	90	14	102,5	686	624	490	36	22	M 20 x 130	931	10.9	650	181	27,23	188

# 3071 Standard-Range

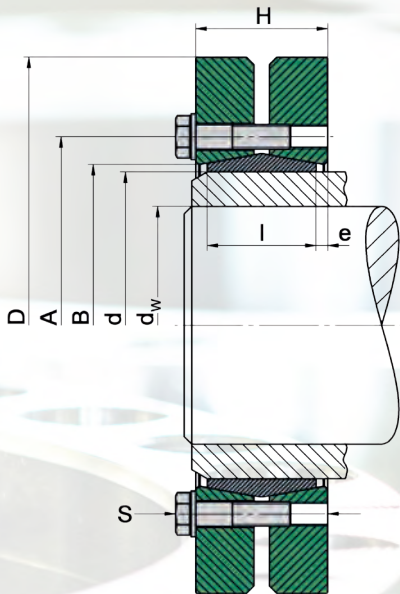

## Used symbols

d	[mm]	Nominal diameter of the shrink disc
$d_w$	[mm]	Shaft diameter
$M_{max}$	[Nm]	Maximal transmittable torque
D	[mm]	Outer diameter
l	[mm]	Length of the inner ring
e	[mm]	Excess length
H	[mm]	Width of the shrink disc
A	[mm]	Pitch circle diameter
B	[mm]	Attachment size
$M_A$	[Nm]	Tightening torque of the clamping screws
Z		Number of clamping screws
S		Size of the clamping screws
$n_{max}$	[min <sup>-1</sup> ]	Permitted rotational frequency
$p_N$	[N/mm <sup>2</sup> ]	Average pressure to the hub
I	[kgm <sup>2</sup> ]	Moment of inertia

## Design of the shrink disc

$d < 115$	Discs galvanized without washers
$d \geq 115$	Discs painted with washers

Dimensions H & e in unlocked position

Hexagon head bolts are used as standard. Upon request we provide all sized shrink discs with hexagon socket head bolts (Inbus). (See ordering information)

Variation from the standard shaft diameter  $d_w$

> mm	≤ mm	minimal - mm	maximal + mm
10	30	-1	1
30	50	-3	2
50	140	-5	5
140	180	-10	5
180	320	-15	10
320	500	-20	10
500	700	-30	20
700	820	-40	20

$$M = M_{max(Catalog)} \left( \frac{d_w(target)}{d_w(Catalog)} \right)^2$$

(see Basics - Calculation)

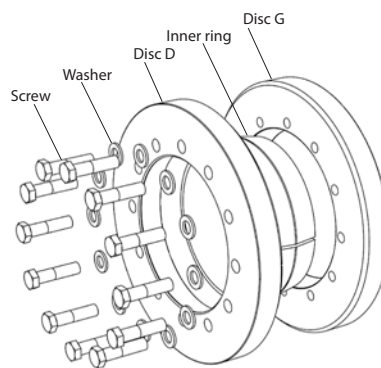

min. yield strength Rp0,2	N/mm <sup>2</sup>
Solid shaft	290
Hub	350

Ordering information: TAS 3071 - d (for example: TAS 3071-200 ... (Further sizes on request with Inbus: TAS 3071 - d - Inbus (for example: TAS 3071-200-Inbus)

# 3071 Standard-Range

<b>d</b> mm	<b>d<sub>w</sub></b> mm	<b>M<sub>max</sub></b> Nm	<b>D</b> mm	<b>l</b> mm	<b>e</b> mm	<b>H</b> mm	<b>A</b> mm	<b>B</b> mm	<b>M<sub>A</sub></b> Nm	<b>Z</b> Stk	<b>S</b>	<b>DIN</b>	<b>Class</b>	<b>n<sub>max</sub></b> min <sup>-1</sup>	<b>P<sub>N</sub></b> N/mm <sup>2</sup>	<b>I</b> kgm <sup>2</sup>	<b>Weight</b> kg
14	11	27	37	9	1,5	12	24	15	2,4	3	M 4 x 10	933	8.8	15400	254	0,0000137	0,07
16	13	59	41	12	1,5	15	27	17	4,8	3	M 5 x 12	933	8.8	13900	240	0,0000266	0,11
18	15	110	43	12	1,5	15	29	19	4,8	4	M 5 x 12	933	8.8	13300	285	0,0000326	0,12
20	17	220	48	14	2,75	19,5	34	24	6	5	M 5 x 18	933	10.9	11900	322	0,0000642	0,19
21	18	240	48	14	2,75	19,5	34	24	6	5	M 5 x 18	933	10.9	11900	307	0,0000618	0,18
22	19	250	48	14	2,75	19,5	36	26	6	5	M 5 x 18	933	10.9	11900	293	0,0000627	0,18
24	20	300	50	14	2,5	19	36	26	6	6	M 5 x 18	933	10.9	11400	322	0,0000731	0,19
30	25	360	60	16	2,75	21,5	44	32	6	6	M 5 x 18	931	10.9	9500	225	0,0001687	0,30
36	30	640	72	18	2,75	23,5	52	38	12	5	M 6 x 20	933	10.9	7900	231	0,0003888	0,48
38	31	910	80	20	3	26	56	41	12	7	M 6 x 20	933	10.9	7100	275	0,0006569	0,67
40	32	740	75	19	2,75	24,5	57	43	12	6	M 6 x 20	933	10.9	7600	236	0,0004967	0,55
41	33	940	80	20	2,75	25,5	61	46	12	7	M 6 x 20	933	10.9	7100	255	0,0006465	0,64
44	35	970	80	20	2,75	25,5	61	47	12	7	M 6 x 20	933	10.9	7100	238	0,0006356	0,61
50	40	1200	90	22	3	28	70	53	12	8	M 6 x 25	933	10.9	6300	217	0,0010998	0,83
55	45	1500	100	23	3,75	30,5	75	58	12	8	M 6 x 25	933	10.9	5700	189	0,0017909	1,1
62	50	2100	110	23	3,75	30,5	86	66	12	10	M 6 x 25	933	10.9	5200	210	0,0025909	1,3
68	55	2200	115	23	3,75	30,5	86	72	12	10	M 6 x 25	933	10.9	4900	191	0,0031236	1,4
75	60	3600	138	25	3,75	32,5	100	79	30	7	M 8 x 30	933	10.9	4100	233	0,0070923	2,3
80	65	4100	145	25	3,75	32,5	100	84	30	7	M 8 x 30	933	10.9	3900	218	0,0085703	2,5
90	70	6000	155	30	4,5	39	114	94	30	10	M 8 x 35	931	10.9	3600	231	0,0132516	3,3
100	75	7300	170	34	5	44	124	104	30	12	M 8 x 35	931	10.9	3300	220	0,0213950	4,4
110	80	8900	185	39	5,5	50	136	114	59	9	M 10 x 40	931	10.9	3000	208	0,0347437	6,0
115	80	9300	200	40	5	50	150	124	59	10	M 10 x 40	931	10.9	2800	215	0,0485678	7,3
120	85	9600	200	40	5	50	150	124	59	10	M 10 x 40	931	10.9	2800	206	0,0476000	7,0
125	90	13100	215	42	6	54	160	134	59	12	M 10 x 40	931	10.9	2600	226	0,0672619	8,7
140	100	17900	230	46	7,25	60,5	175	146	100	10	M 12 x 50	931	10.9	2400	224	0,0996875	11
155	110	23900	265	50	7,25	64,5	192	165	100	12	M 12 x 50	931	10.9	2100	224	0,1885000	16
165	120	38700	290	56	7,5	71	210	175	250	8	M 16 x 55	931	10.9	1900	258	0,3061438	22
175	130	42600	300	56	7,5	71	220	185	250	8	M 16 x 55	931	10.9	1900	243	0,3467969	23
185	140	59000	330	71	7,5	86	236	195	250	10	M 16 x 70	931	10.9	1700	227	0,6261719	35
195	150	79500	350	71	7,5	86	246	210	250	12	M 16 x 70	931	10.9	1600	258	0,8026250	40
200	155	81700	350	71	7,5	86	246	210	250	12	M 16 x 70	931	10.9	1600	252	0,7921875	39
220	165	103000	370	88	8	104	270	230	250	15	M 16 x 80	931	10.9	1500	231	1,1813	51
240	180	144000	405	92	8,5	109	295	248	490	12	M 20 x 80	931	10.9	1400	254	1,7730	64
245	185	147000	410	95	8	111	298	251	490	12	M 20 x 80	931	10.9	1300	241	1,9105	67
260	190	170000	440	103	8,5	120	321	268	490	14	M 20 x 90	931	10.9	1300	244	2,7426	84
280	210	224000	460	114	10	134	346	288	490	16	M 20 x 100	931	10.9	1200	234	3,5888	99
300	230	287000	485	122	10	142	364	308	490	18	M 20 x 100	931	10.9	1100	230	4,6751	115
320	240	326000	520	122	10	142	386	328	490	20	M 20 x 100	931	10.9	1100	239	6,1978	133
340	250	401000	570	134	11	156	408	348	490	24	M 20 x 110	931	10.9	1000	246	10,08	183
350	270	456000	580	140	11	162	432	358	490	24	M 20 x 110	931	10.9	980	229	11,07	193
360	290	519000	590	140	11	162	432	368	490	24	M 20 x 110	931	10.9	970	222	11,76	197
380	300	635000	645	144	12	168	458	387	840	20	M 24 x 120	931	10.9	880	245	17,86	255
390	310	697000	660	144	12	168	468	397	840	21	M 24 x 120	931	10.9	860	251	19,54	266



# 3071 Standard-Range

<b>d</b> mm	<b>d<sub>w</sub></b> mm	<b>M<sub>max</sub></b> Nm	<b>D</b> mm	<b>l</b> mm	<b>e</b> mm	<b>H</b> mm	<b>A</b> mm	<b>B</b> mm	<b>M<sub>A</sub></b> Nm	<b>Z</b> Stk	<b>S</b>	<b>DIN</b>	<b>Class</b>	<b>n<sub>max</sub></b> min <sup>-1</sup>	<b>p<sub>N</sub></b> N/mm <sup>2</sup>	<b>I</b> kgm <sup>2</sup>	<b>Weight</b> kg
400	320	722000	680	144	12	168	480	407	840	21	M 24 x 120	931	10.9	840	245	22,10	284
420	340	891000	690	164	12	188	504	427	840	24	M 24 x 130	931	10.9	830	234	25,94	318
440	350	891000	750	177	12,5	202	527	447	840	24	M 24 x 140	931	10.9	760	207	39,13	414
460	370	1127000	770	177	12,5	202	547	468	840	28	M 24 x 140	931	10.9	740	231	43,04	428
480	390	1290000	800	188	12,5	213	570	488	840	30	M 24 x 140	931	10.9	710	223	52,77	485
500	410	1431000	850	188	12,5	213	590	508	1250	24	M 27 x 150	931	10.9	670	225	68,08	560
530	440	1961000	900	215	12,5	240	620	538	1250	30	M 27 x 180	931	10.9	630	232	93,54	686
560	460	2165000	950	215	12,5	240	650	568	1250	32	M 27 x 180	931	10.9	600	234	116	763
590	480	2514000	980	235	15	265	685	600	1250	36	M 27 x 180	931	10.9	580	229	142	869
620	510	2856000	1020	235	15	265	715	630	1250	38	M 27 x 180	931	10.9	560	230	166	931
660	540	3676000	1100	260	15	290	760	670	1700	38	M 30 x 200	931	10.9	520	238	246	1195
700	580	4232000	1200	260	15	290	800	710	1700	40	M 30 x 200	931	10.9	470	236	354	1466
720	600	4639000	1230	260	15	290	820	730	1700	42	M 30 x 200	931	10.9	460	241	390	1535
750	620	4967000	1230	280	17,5	315	855	762	1700	44	M 30 x 220	931	10.9	460	225	420	1619
800	660	5501000	1310	280	17,5	315	905	812	1700	46	M 30 x 220	931	10.9	430	220	540	1833
850	700	6322000	1330	310	17,5	345	965	862	1700	50	M 30 x 250	931	10.9	430	204	604	1938
900	740	6950000	1400	310	17,5	345	1015	912	1700	52	M 30 x 250	931	10.9	400	200	738	2130
950	780	8421000	1550	340	20	380	1075	962	2800	42	M 36 x 260	931	10.9	370	199	1285	3111
1000	820	10562000	1620	340	20	380	1125	1012	2800	50	M 36 x 260	931	10.9	350	225	1526	3369



# 3071 Half/Split (Standard-Range)

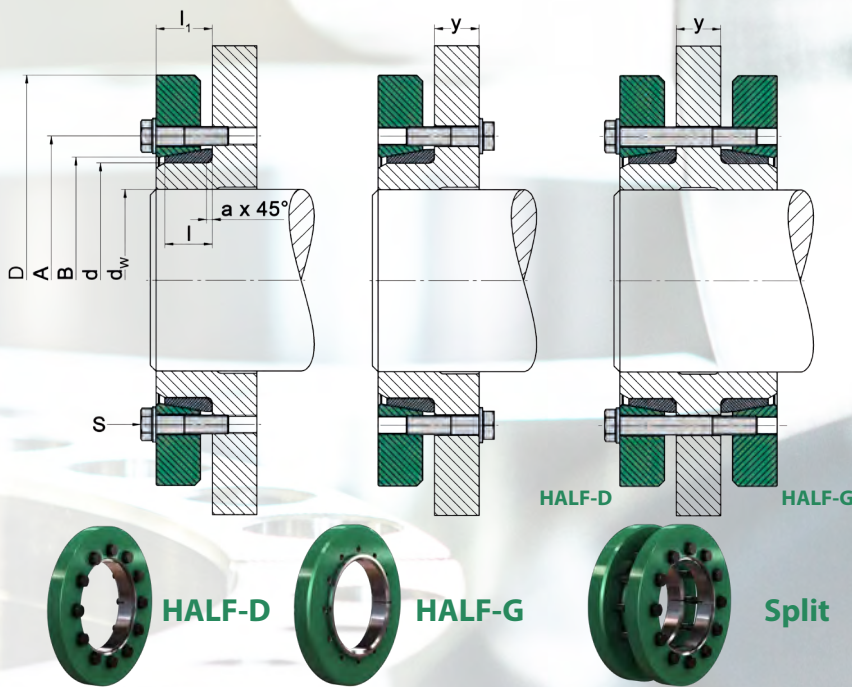

## Used symbols

d	[mm]	Nominal diameter of the shrink disc
$d_w$	[mm]	Shaft diameter
$M_{max}$	[Nm]	Maximal transmittable torque
D	[mm]	Outer diameter
l	[mm]	Length of the inner ring
e	[mm]	Excess length
H	[mm]	Width of the shrink disc
A	[mm]	Pitch circle diameter
B	[mm]	Attachment size
$M_A$	[Nm]	Tightening torque of the clamping screws
Z		Number of clamping screws
S		Size of the clamping screws
$n_{max}$	[min <sup>-1</sup> ]	Permitted rotational frequency
$p_N$	[N/mm <sup>2</sup> ]	Average Pressure to the hub
I	[kgm <sup>2</sup> ]	Moment of inertia

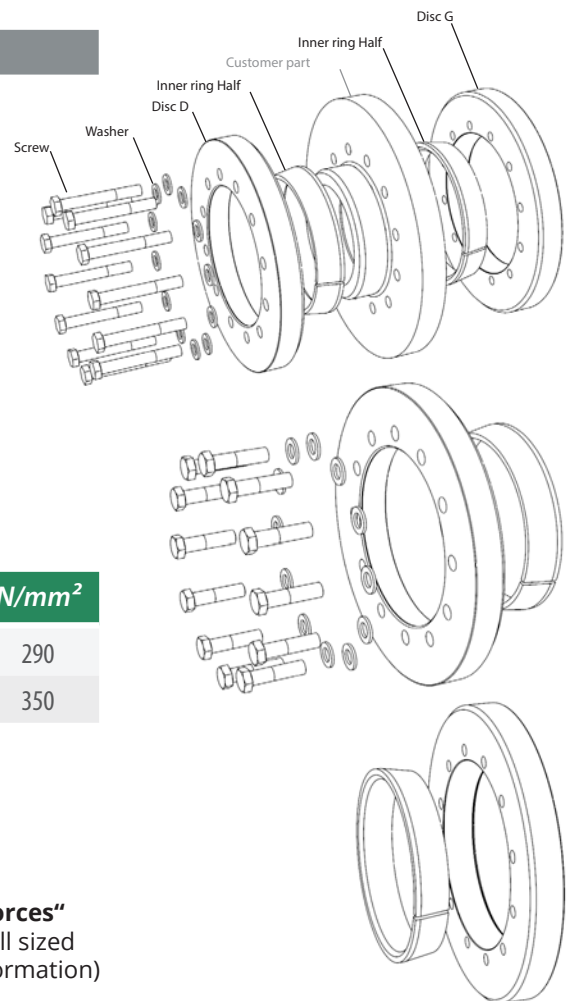

## Design of the shrink disc

$d < 115$	Discs galvanized without washers
$d \geq 115$	Discs painted with washers

min. yield strength Rp0,2	N/mm <sup>2</sup>
Solid shaft	290
Hub	350

Dimensions H & e in unlocked position

Deviation from the standard shaft diameter  $d_w$  see the table „3071 Standard-Range“ and „Calculation of transmissible torques and forces“ Hexagon head bolts are used as standard. Upon request we provide all sized shrink discs with hexagon socket head bolts (Inbus). (See ordering information)

Ordering information: TAS 3071Typ - d - y (z.B.: TAS 3071GET-200-Y60 oder TAS 3071HALB-G-200-Y30 oder TAS 3071HALB-D-200) with Inbus: TAS 3071Typ - d - y - Inbus (z.B.: TAS 3071GET-200-Y60-Inbus u.s.w.)

# 3071 Half/Split (Standard-Range)

## Please note:

All values refer to shrink disk design **HALF!** Please provide us the dimension of „y“ or the length of screws. Otherwise we can not provide appropriate screws! (see ordering information)

Applies to shrink disc design HALF-G:

- The required screw length is: Screw length (**3071 Standard-Range**) -  $l_1 + 2 a + y$  (rounded up to standard lengths)

Applies to shrink disc design SPLIT:

- The design consists of 1x HALF-D + 1x HALF-G
- Delivery is possible with or without screws
- Maximum transmittable torque:  $M_{ges} = 2 M_{max}$
- The required screw length: Screw length (**3071 Standard-Range**) +  $2 a + y$  (rounded up to standard lengths)

											HALF-D only							
d mm	d <sub>w</sub> mm	M <sub>max</sub> Nm	D mm	l mm	a mm	l <sub>1</sub> mm	A mm	B mm	M <sub>A</sub> Nm	Z Stk	d <sub>B</sub> mm	S	DIN	Class	n <sub>max</sub> min <sup>-1</sup>	p <sub>N</sub> N/mm <sup>2</sup>	I kgm <sup>2</sup>	Weight kg
14	11	14	37	6	0,8	7,5	24	15	2,4	3	4,5	M 4 x 12	933	10.9	15400	257	0,0000078	0,04
16	13	39	41	7,5	0,8	9	27	17	4,8	3	5,5	M 5 x 14	933	10.9	13900	282	0,0000121	0,05
18	15	59	43	7,5	0,8	9	29	19	4,8	4	5,5	M 5 x 14	933	8.8	13300	285	0,0000163	0,06
20	17	110	48	8,5	1,5	11,25	34	24	6	5	5,5	M 5 x 18	933	10.9	11900	322	0,0000304	0,09
21	18	120	48	8,5	1,5	11,25	34	24	6	5	5,5	M 5 x 18	933	10.9	11900	307	0,0000309	0,09
22	19	120	48	8,5	1,5	11,25	36	26	6	5	5,5	M 5 x 18	933	10.9	11900	293	0,0000314	0,09
24	20	150	50	9	1,5	11,5	36	26	6	6	5,5	M 5 x 18	933	10.9	11400	322	0,0000366	0,09
30	25	180	60	10	2	12,75	44	32	6	6	5,5	M 5 x 18	931	10.9	9500	225	0,0000844	0,15
36	30	320	72	11	2	13,75	52	38	12	5	6,6	M 6 x 20	933	10.9	7900	231	0,0001944	0,24
38	31	450	80	12	2	15	56	41	12	7	6,6	M 6 x 22	933	10.9	7100	275	0,0003334	0,34
40	32	370	75	11,5	2	14,25	57	43	12	6	6,6	M 6 x 22	933	10.9	7600	236	0,0002438	0,27
41	33	470	80	12	2	14,75	61	46	12	7	6,6	M 6 x 22	933	10.9	7100	255	0,0003232	0,32
44	35	480	80	12	2	14,75	61	47	12	7	6,6	M 6 x 22	933	10.9	7100	238	0,0003126	0,30
50	40	640	90	13	2	16	70	53	12	8	6,6	M 6 x 25	933	10.9	6300	217	0,0005432	0,41
55	45	750	100	14	2,5	17,75	75	58	12	8	6,6	M 6 x 25	933	10.9	5700	189	0,0009118	0,56
62	50	1000	110	14	2,5	17,75	86	66	12	10	6,6	M 6 x 25	933	10.9	5200	210	0,0013154	0,66
68	55	1100	115	14	2,5	17,75	86	72	12	10	6,6	M 6 x 25	933	10.9	4900	191	0,0015395	0,69
75	60	1800	138	16,5	3	20,25	100	79	30	7	9	M 8 x 30	933	10.9	4100	233	0,0037004	1,2
80	65	2000	145	16,5	3	20,25	100	84	30	7	9	M 8 x 30	933	10.9	3900	218	0,0044566	1,3
90	70	3000	155	20	4	24,5	114	94	30	10	9	M 8 x 35	931	10.9	3600	231	0,0068266	1,7
100	75	3600	170	22	4	27	124	104	30	12	9	M 8 x 35	931	10.9	3300	220	0,0106975	2,2
110	80	4400	185	24,5	4	30	136	114	59	9	11	M 10 x 40	931	10.9	3000	208	0,0173719	3,0
115	80	4600	200	25	4	30	150	124	59	10	11	M 10 x 40	931	10.9	2800	215	0,0239512	3,6
120	85	4800	200	25	4	30	150	124	59	10	11	M 10 x 40	931	10.9	2800	206	0,0238000	3,5
125	90	6500	215	26	5	32	160	134	59	12	11	M 10 x 45	931	10.9	2600	226	0,0332444	4,3
140	100	8900	230	28	5	35,25	175	146	100	10	13,5	M 12 x 50	931	10.9	2400	224	0,0480312	5,3
155	110	11900	265	30	5	37,25	192	165	100	12	13,5	M 12 x 50	931	10.9	2100	224	0,0942500	8,0
165	120	19300	290	33	5	40,5	210	175	250	8	17,5	M 16 x 55	931	10.9	1900	258	0,1530719	11
175	130	21300	300	33	5	40,5	220	185	250	8	17,5	M 16 x 55	931	10.9	1900	243	0,1658594	11



# 3071 Half/Split (Standard-Range)

											HALF-D only							
<i>d</i> mm	<i>d<sub>w</sub></i> mm	<i>M<sub>max</sub></i> Nm	<i>D</i> mm	<i>l</i> mm	<i>a</i> mm	<i>l<sub>1</sub></i> mm	<i>A</i> mm	<i>B</i> mm	<i>M<sub>A</sub></i> Nm	<i>Z</i> Stk	<i>d<sub>B</sub></i> mm	<i>S</i>	<i>DIN</i>	<i>Class</i>	<i>n<sub>max</sub></i> min <sup>-1</sup>	<i>P<sub>N</sub></i> N/mm <sup>2</sup>	<i>I</i> kgm <sup>2</sup>	<i>Weight</i> kg
185	140	29500	330	40,5	5	48	236	195	250	10	17,5	M 16 x 70	931	10.9	1700	227	0,3220312	18
195	150	39700	350	40,5	5	48	246	210	250	12	17,5	M 16 x 70	931	10.9	1600	258	0,4013125	20
200	155	40800	350	40,5	5	48	246	210	250	12	17,5	M 16 x 70	931	10.9	1600	252	0,3859375	19
220	165	51800	370	52	8	60	270	230	250	15	17,5	M 16 x 80	931	10.9	1500	231	0,6022250	26
240	180	72400	405	54	8	62,5	295	248	490	12	22	M 20 x 90	931	10.9	1400	254	0,8865000	32
245	185	73900	410	55,5	8	63,5	298	251	490	12	22	M 20 x 90	931	10.9	1300	241	0,9410156	33
260	190	85300	440	59,5	8	68	321	268	490	14	22	M 20 x 90	931	10.9	1300	244	1,3713	42
280	210	112000	460	67	10	77	346	288	490	16	22	M 20 x 100	931	10.9	1200	234	1,7762	49
300	230	143000	485	71	10	81	364	308	490	18	22	M 20 x 100	931	10.9	1100	230	2,3172	57
320	240	163000	520	71	10	81	386	328	490	20	22	M 20 x 100	931	10.9	1100	239	3,0756	66
340	250	163000	570	77	10	88	408	348	490	24	22	M 20 x 110	931	10.9	1000	205	5,0658	92
350	270	228000	580	80	10	91	432	358	490	24	22	M 20 x 110	931	10.9	980	229	5,5068	96
360	290	259000	590	80	10	91	432	368	490	24	22	M 20 x 110	931	10.9	970	222	5,8518	98
380	300	317000	645	85	13	97	458	387	840	20	26	M 24 x 120	931	10.9	880	245	8,8967	127
390	310	348000	660	85	13	97	468	397	840	21	26	M 24 x 120	931	10.9	860	251	9,7705	133
400	320	361000	680	85	13	97	480	407	840	21	26	M 24 x 120	931	10.9	840	245	11,05	142
420	340	445000	690	95	13	107	504	427	840	24	26	M 24 x 130	931	10.9	830	234	12,97	159
440	350	445000	750	101,5	13	114	527	447	840	24	26	M 24 x 140	931	10.9	760	207	19,56	207
460	370	478000	770	101,5	13	114	547	468	840	28	26	M 24 x 140	931	10.9	740	198	21,52	214
480	390	599000	800	109	15	121,5	570	488	840	30	26	M 24 x 150	931	10.9	710	208	26,44	243
500	410	715000	850	109	15	121,5	590	508	1250	24	30	M 27 x 150	931	10.9	670	225	34,04	280
530	440	980000	900	122,5	15	135	620	538	1250	30	30	M 27 x 170	931	10.9	630	232	46,77	343
560	460	1082000	950	122,5	15	135	650	568	1250	32	30	M 27 x 170	931	10.9	600	234	58,07	382
590	480	1257000	980	132,5	15	147,5	685	600	1250	36	30	M 27 x 180	931	10.9	580	229	71,15	435
620	510	1428000	1020	132,5	15	147,5	715	630	1250	38	30	M 27 x 180	931	10.9	560	230	82,99	466
660	540	1838000	1100	145	15	160	760	670	1700	38	33	M 30 x 200	931	10.9	520	238	123	598
700	580	2116000	1200	145	15	160	800	710	1700	40	33	M 30 x 200	931	10.9	470	236	177	733
720	600	2319000	1230	145	15	160	820	730	1700	42	33	M 30 x 200	931	10.9	460	241	195	767
750	620	2483000	1230	155	15	172,5	855	762	1700	44	33	M 30 x 220	931	10.9	460	225	210	810
800	660	2750000	1310	155	15	172,5	905	812	1700	46	33	M 30 x 220	931	10.9	430	220	270	917
850	700	3161000	1330	170	15	187,5	965	862	1700	50	33	M 30 x 230	931	10.9	430	204	302	969
900	740	3475000	1400	170	15	187,5	1015	912	1700	52	33	M 30 x 230	931	10.9	400	200	369	1065
950	780	4210000	1550	185	15	205	1075	962	2800	42	39	M 36 x 250	931	10.9	370	199	643	1556
1000	820	5281000	1620	185	15	205	1125	1012	2800	50	39	M 36 x 250	931	10.9	350	225	763	1685

# 3081 Standard-Range (strengthened)

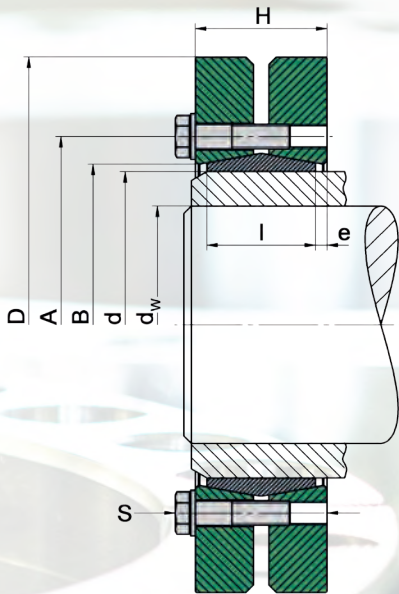

## Used symbols

d	[mm]	Nominal diameter of the shrink disc
$d_w$	[mm]	Shaft diameter
$M_{max}$	[Nm]	Maximal transmittable torque
D	[mm]	Outer diameter
l	[mm]	Length of the inner ring
e	[mm]	Excess length
H	[mm]	Width of the shrink disc
A	[mm]	Pitch circle diameter
B	[mm]	Attachment size
$M_A$	[Nm]	Tightening torque of the clamping screws
Z		Number of clamping screws
S		Size of the clamping screws
$n_{max}$	[min <sup>-1</sup> ]	Permitted rotational frequency
$p_N$	[N/mm <sup>2</sup> ]	Average pressure to the hub
I	[kgm <sup>2</sup> ]	Moment of inertia

## Design of the shrink disc

$d < 115$	Discs galvanized without washers
$d \geq 115$	Discs painted with washers

Dimensions H & e in unlocked position

Hexagon head bolts are used as standard. Upon request we provide all sized shrink discs with hexagon socket head bolts (Inbus). (See ordering information)

## Variation from the standard shaft diameter $d_w$

> mm	≤ mm	minimal - mm	maximal + mm
10	30	-1	1
30	50	-3	2
50	140	-5	5
140	180	-10	5
180	320	-15	10
320	500	-20	10
500	700	-30	20
700	820	-40	20

$$M = M_{max(Catalog)} \left( \frac{d_w(target)}{d_w(Catalog)} \right)^2$$

(see Basics - Calculation)

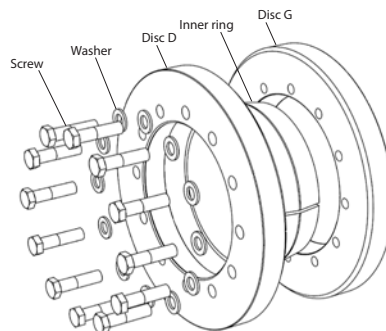

min. yield strength Rp0,2	N/mm <sup>2</sup>
Solid shaft	350
Hub	450

Ordering information: TAS 3081 - d (z.B.: TAS 3081-200 ... (further sizes on request)  
with Inbus: TAS 3081 - d - Inbus (z.B.: TAS 3081-200-Inbus)

# 3081 Standard-Range (strengthened)

<i>d</i> mm	<i>d<sub>w</sub></i> mm	<i>M<sub>max</sub></i> Nm	<i>D</i> mm	<i>l</i> mm	<i>e</i> mm	<i>H</i> mm	<i>A</i> mm	<i>B</i> mm	<i>M<sub>A</sub></i> Nm	<i>Z</i> Stk	<i>S</i>	<i>DIN</i>	<i>Class</i>	<i>n<sub>max</sub></i> min <sup>-1</sup>	<i>p<sub>N</sub></i> N/mm <sup>2</sup>	<i>I</i> kgm <sup>2</sup>	<i>Weight</i> kg
14	11	48	37	9	1,5	12	24	15	4	3	M 4 x 10	933	12.9	15400	344	0,000137	0,07
30	25	520	60	16	2,75	21,5	44	32	8	6	M 5 x 18	931	12.9	9500	300	0,0001687	0,30
36	30	780	72	18	2,75	23,5	52	38	14	5	M 6 x 20	933	12.9	7900	271	0,0003888	0,48
38	31	1100	80	20	3	26	56	41	14	7	M 6 x 20	933	12.9	7100	324	0,0006569	0,67
40	32	910	75	19	2,75	24,5	57	43	14	6	M 6 x 20	933	12.9	7600	277	0,0004967	0,55
50	40	1500	90	22	3	28	70	53	14	8	M 6 x 25	933	12.9	6300	255	0,0010998	0,83
55	45	1800	100	23	3,75	30,5	75	58	14	8	M 6 x 25	933	12.9	5700	222	0,0017909	1,1
62	50	2600	110	23	3,75	30,5	86	66	14	10	M 6 x 25	933	12.9	5200	246	0,0025909	1,3
68	55	2700	115	23	3,75	30,5	86	72	14	10	M 6 x 25	933	12.9	4900	225	0,0031236	1,4
75	60	4400	138	25	3,75	32,5	100	79	35	7	M 8 x 30	933	12.9	4100	272	0,0070923	2,3
80	65	4900	145	25	3,75	32,5	100	84	35	7	M 8 x 30	933	12.9	3900	255	0,0085703	2,5
90	70	7200	155	30	4,5	39	114	94	35	10	M 8 x 35	931	12.9	3600	269	0,0132516	3,3
100	75	8800	170	34	5	44	124	104	35	12	M 8 x 35	931	12.9	3300	257	0,0213950	4,4
110	80	10800	185	39	5,5	50	136	114	69	9	M 10 x 40	931	12.9	3000	243	0,0347437	6,0
115	80	11400	200	40	5	50	150	124	69	10	M 10 x 40	931	12.9	2800	252	0,0485678	7,3
120	85	11700	200	40	5	50	150	124	69	10	M 10 x 40	931	12.9	2800	241	0,0476000	7,0
125	90	15900	215	42	6	54	160	134	69	12	M 10 x 40	931	12.9	2600	265	0,0672619	8,7
140	100	21700	230	46	7,25	60,5	175	146	120	10	M 12 x 50	931	12.9	2400	263	0,0996875	11
155	110	28900	265	50	7,25	64,5	192	165	120	12	M 12 x 50	931	12.9	2100	262	0,1885000	16
165	120	46400	290	56	7,5	71	210	175	290	8	M 16 x 55	931	12.9	1900	303	0,3061438	22
175	130	51200	300	56	7,5	71	220	185	290	8	M 16 x 55	931	12.9	1900	286	0,3467969	23
185	140	70700	330	71	7,5	86	236	195	290	10	M 16 x 70	931	12.9	1700	266	0,6261719	35
195	150	94900	350	71	7,5	86	246	210	290	12	M 16 x 70	931	12.9	1600	303	0,8026250	40
200	155	97700	350	71	7,5	86	246	210	290	12	M 16 x 70	931	12.9	1600	296	0,7921875	39
220	165	124000	370	88	8	104	270	230	290	15	M 16 x 80	931	12.9	1500	271	1,1813	51
240	180	171000	405	92	8,5	109	295	248	570	12	M 20 x 80	931	12.9	1400	296	1,7730	64
245	185	175000	410	95	8	111	298	251	570	12	M 20 x 80	931	12.9	1300	281	1,9105	67
260	190	203000	440	103	8,5	120	321	268	570	14	M 20 x 90	931	12.9	1300	285	2,7426	84
280	210	266000	460	114	10	134	346	288	570	16	M 20 x 100	931	12.9	1200	273	3,5888	99
300	230	340000	485	122	10	142	364	308	570	18	M 20 x 100	931	12.9	1100	268	4,6751	115
320	240	386000	520	122	10	142	386	328	570	20	M 20 x 100	931	12.9	1100	279	6,1978	133
340	250	474000	570	134	11	156	408	348	570	24	M 20 x 110	931	12.9	1000	287	10,08	183
350	270	539000	580	140	11	162	432	358	570	24	M 20 x 110	931	12.9	980	267	11,07	193
360	290	613000	590	140	11	162	432	368	570	24	M 20 x 110	931	12.9	970	259	11,76	197
380	300	750000	645	144	12	168	458	387	980	20	M 24 x 120	931	12.9	880	287	17,86	255
390	310	824000	660	144	12	168	468	397	980	21	M 24 x 120	931	12.9	860	294	19,54	266
400	320	853000	680	144	12	168	480	407	980	21	M 24 x 120	931	12.9	840	286	22,10	284
420	340	1052000	690	164	12	188	504	427	980	24	M 24 x 130	931	12.9	830	274	25,94	318
440	350	1054000	750	177	12,5	202	527	447	980	24	M 24 x 140	931	12.9	760	242	39,13	414
460	370	1331000	770	177	12,5	202	547	468	980	28	M 24 x 140	931	12.9	740	270	43,04	428
480	390	1523000	800	188	12,5	213	570	488	980	30	M 24 x 140	931	12.9	710	261	52,77	485
500	410	1691000	850	188	12,5	213	590	508	1450	24	M 27 x 150	931	12.9	670	263	68,08	560
530	440	2314000	900	215	12,5	240	620	538	1450	30	M 27 x 180	931	12.9	630	272	93,54	686
560	460	2554000	950	215	12,5	240	650	568	1450	32	M 27 x 180	931	12.9	600	274	116	763
590	480	2967000	980	235	15	265	685	600	1450	36	M 27 x 180	931	12.9	580	268	142	869
620	510	3370000	1020	235	15	265	715	630	1450	38	M 27 x 180	931	12.9	560	269	166	931



# 3081 Standard-Range (strengthened)

<b>d</b> mm	<b>d<sub>w</sub></b> mm	<b>M<sub>max</sub></b> Nm	<b>D</b> mm	<b>l</b> mm	<b>e</b> mm	<b>H</b> mm	<b>A</b> mm	<b>B</b> mm	<b>M<sub>A</sub></b> Nm	<b>Z</b> Stk	<b>S</b>	<b>DIN</b>	<b>Class</b>	<b>n<sub>max</sub></b> min <sup>-1</sup>	<b>p<sub>N</sub></b> N/mm <sup>2</sup>	<b>I</b> kgm <sup>2</sup>	<b>Weight</b> kg
<b>660</b>	540	4329000	1100	260	15	290	760	670	1950	38	M 30 x 200	931	12.9	520	278	246	1195
<b>700</b>	580	4980000	1200	260	15	290	800	710	1950	40	M 30 x 200	931	12.9	470	276	354	1466
<b>720</b>	600	5456000	1230	260	15	290	820	730	1950	42	M 30 x 200	931	12.9	460	282	390	1535
<b>750</b>	620	5844000	1230	280	17,5	315	855	762	1950	44	M 30 x 220	931	12.9	460	263	420	1619
<b>800</b>	660	6475000	1310	280	17,5	315	905	812	1950	46	M 30 x 220	931	12.9	430	258	540	1833
<b>850</b>	700	7443000	1330	310	17,5	345	965	862	1950	50	M 30 x 250	931	12.9	430	238	604	1938
<b>900</b>	740	8180000	1400	310	17,5	345	1015	912	1950	52	M 30 x 250	931	12.9	400	234	738	2130
<b>950</b>	780	10005000	1550	340	20	380	1075	962	3300	42	M 36 x 260	931	12.9	370	234	1285	3111
<b>1000</b>	820	12541000	1620	340	20	380	1125	1012	3300	50	M 36 x 260	931	12.9	350	265	1526	3369



**TAS**  
**SCHÄFER**



# 3091 Heavy-Range

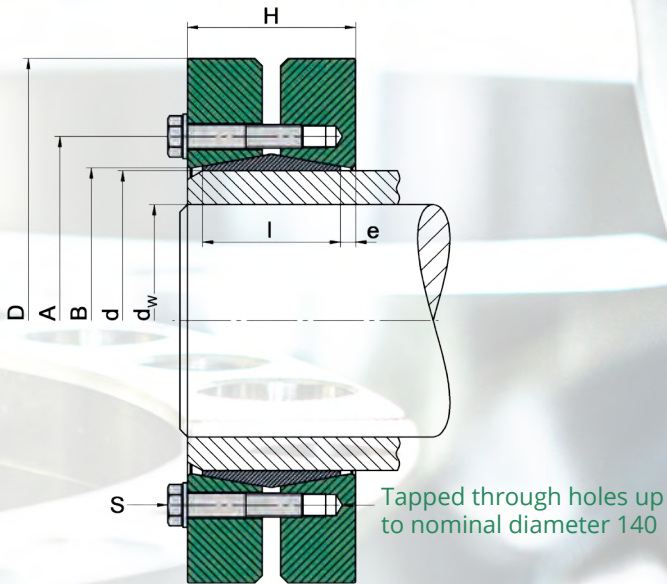

## Used symbols

d	[mm]	Nominal diameter of the shrink disc
$d_w$	[mm]	Shaft diameter
$M_{max}$	[Nm]	Maximal transmittable torque
D	[mm]	Outer diameter
l	[mm]	Length of the inner ring
e	[mm]	Excess length
H	[mm]	Width of the shrink disc
A	[mm]	Pitch circle diameter
B	[mm]	Attachment size
$M_A$	[Nm]	Tightening torque of the clamping screws
Z		Number of clamping screws
S		Size of the clamping screws
$n_{max}$	[min <sup>-1</sup> ]	Permitted rotational frequency
$p_N$	[N/mm <sup>2</sup> ]	Average pressure to the hub
I	[kgm <sup>2</sup> ]	Moment of inertia

## Design of the disc

$d < 115$	Discs galvanized without washers
$d \geq 115$	Discs painted with washers

Dimensions H & e in unlocked position

Hexagon head bolts are used as standard. Upon request we provide all sized shrink discs with hexagon socket head bolts (Inbus). (See ordering information)

Variation from the standard shaft diameter $d_w$			
> mm	≤ mm	minimal - mm	maximal + mm
40	50	-3	2
50	140	-5	5
140	180	-10	5
180	320	-15	10
320	440	-20	10
440	600	-30	10

$$M = M_{max(Catalog)} \left( \frac{d_w(target)}{d_w(Catalog)} \right)^2$$

(see Basics - Calculation)

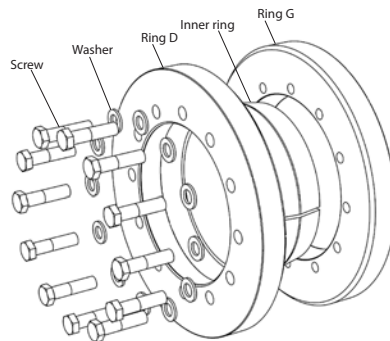

min. yield strength Rp0,2	N/mm <sup>2</sup>
Solid shaft	290
Hub	350

Ordering information: TAS 3091 - d (e.g.: TAS 3091-200 ... (Further sizes on request))  
with Inbus: TAS 3091 - d - Inbus (e.g.: TAS 3091-200-Inbus)



# 3091 Heavy-Range

<i>d</i> mm	<i>d<sub>w</sub></i> mm	<i>M<sub>max</sub></i> Nm	<i>D</i> mm	<i>l</i> mm	<i>e</i> mm	<i>H</i> mm	<i>A</i> mm	<i>B</i> mm	<i>M<sub>A</sub></i> Nm	<i>Z</i> Stk	<i>S</i>	<i>DIN</i>	<i>Class</i>	<i>n<sub>max</sub></i> min <sup>-1</sup>	<i>p<sub>N</sub></i> N/mm <sup>2</sup>	<i>I</i> kgm <sup>2</sup>	<i>Weight</i> kg
40	30	890	80	25	3,5	32	62	43	30	4	M 8 x 30	933	10.9	7100	249	0,0008300	0,83
44	34	1300	85	28	3	34	66	47	30	5	M 8 x 30	933	10.9	6700	253	0,0011451	1,0
50	40	2500	95	30	4,5	39	73	54	30	7	M 8 x 35	933	10.9	6000	291	0,0020169	1,4
55	45	2900	105	30	4,5	39	78	59	30	7	M 8 x 35	933	10.9	5400	264	0,0029856	1,7
62	50	3200	115	30	4,5	39	85	66	30	7	M 8 x 35	933	10.9	4900	235	0,0042672	2,0
68	55	3900	120	30	4,5	39	92	72	30	8	M 8 x 35	933	10.9	4700	244	0,0049938	2,1
75	60	5900	145	36	5	46	105	84	59	7	M 10 x 40	933	10.9	4100	257	0,0101760	3,3
80	65	6600	145	36	5	46	105	84	59	7	M 10 x 40	933	10.9	3900	241	0,0123412	3,6
90	70	7600	160	40	5	50	116	94	59	8	M 10 x 40	933	10.9	3500	220	0,0202200	4,8
100	75	9800	170	44	5	54	126	104	59	10	M 10 x 45	931	10.9	3300	225	0,0262575	5,4
110	80	12000	185	50	5	60	138	114	59	12	M 10 x 45	931	10.9	3000	216	0,0411134	7,1
120	85	14300	210	55	5	65	155	125	100	10	M 12 x 50	931	10.9	2700	219	0,0731250	10
125	90	15600	215	55	5	65	160	129	100	10	M 12 x 50	931	10.9	2600	210	0,0850438	11
140	100	21000	230	60	7	74	175	144	100	12	M 12 x 55	931	10.9	2400	207	0,1178125	13
155	110	29500	265	66	7	80	198	164	100	15	M 12 x 60	931	10.9	2100	212	0,2356250	20
165	120	48100	290	72	8	88	210	174	250	10	M 16 x 70	931	10.9	1900	251	0,3757219	27
175	130	53100	300	72	8	88	220	184	250	10	M 16 x 70	931	10.9	1900	237	0,4221875	28
185	140	83500	330	92	10	112	236	194	250	14	M 16 x 80	931	10.9	1700	245	0,8229688	46
200	150	95400	350	92	10	112	246	204	250	15	M 16 x 80	931	10.9	1600	243	1,0359000	51
220	165	138000	370	114	10	134	270	224	250	20	M 16 x 90	931	10.9	1500	238	1,5287	66
240	180	180000	405	120	12	144	295	244	490	15	M 20 x 100	931	10.9	1400	243	2,3548	85
260	200	247000	430	136	12	160	321	265	490	18	M 20 x 110	931	10.9	1300	238	3,2825	104
280	220	330000	460	148	12	172	346	285	490	21	M 20 x 120	931	10.9	1200	237	4,6400	128
300	240	388000	485	152	12	176	364	305	490	22	M 20 x 120	931	10.9	1100	225	5,8134	143
320	250	428000	520	160	12	184	386	325	490	24	M 20 x 130	931	10.9	1100	219	7,9220	170
340	260	546000	570	176	12	200	420	345	840	21	M 24 x 130	931	10.9	1000	236	13,10	238
350	280	626000	580	176	12	200	425	355	840	21	M 24 x 130	931	10.9	980	229	13,94	243
360	290	687000	590	180	12	204	432	365	840	22	M 24 x 140	931	10.9	970	228	14,81	248
380	305	719000	645	180	12	204	458	387	840	22	M 24 x 140	931	10.9	880	216	21,65	309
390	310	789000	660	188	12	212	468	397	840	24	M 24 x 140	931	10.9	860	220	24,68	336
400	320	817000	680	188	12	212	480	407	840	24	M 24 x 140	931	10.9	840	214	27,85	358
420	340	1110000	690	214	12	238	504	427	840	30	M 24 x 150	931	10.9	830	224	33,52	411
440	350	1173000	750	224	14	252	527	448	1250	24	M 27 x 170	931	10.9	760	215	49,52	524
460	370	1483000	770	224	14	252	547	468	1250	28	M 27 x 170	931	10.9	740	240	54,40	541
480	390	1694000	800	246	14	274	580	488	1250	30	M 27 x 180	931	10.9	710	224	70,39	647
500	410	1910000	850	246	14	274	600	508	1250	32	M 27 x 180	931	10.9	670	229	90,81	747
530	440	2207000	910	275	14	303	630	538	1250	34	M 27 x 200	931	10.9	630	206	130	939
660	540	4116000	1070	310	15	340	780	670	2800	30	M 36 x 240	931	10.9	530	224	263	1331

# 3091 Half/Split (Heavy-range)

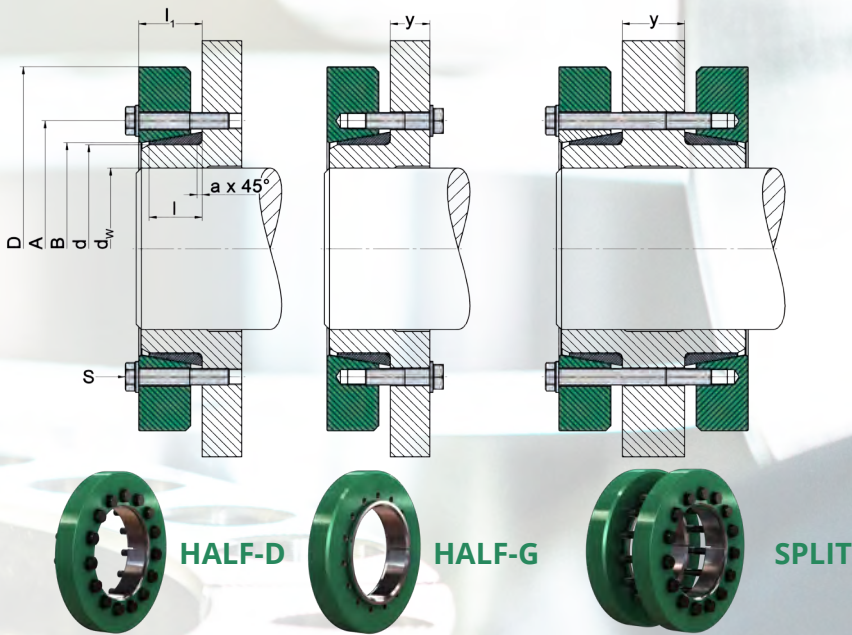

## Used symbols

d	[mm]	Nominal diameter of the shrink disc
$d_w$	[mm]	Shaft diameter
$M_{max}$	[Nm]	Maximal transmittable torque
D	[mm]	Outer diameter
l	[mm]	Length of the inner ring
e	[mm]	Excess length
H	[mm]	Width of the shrink disc
A	[mm]	Pitch circle diameter
B	[mm]	Attachment size
$M_A$	[Nm]	Tightening torque of the clamping screws
Z		Number of clamping screws
S		Size of the clamping screws
$n_{max}$	[min <sup>-1</sup> ]	Permitted rotational frequency
$p_N$	[N/mm <sup>2</sup> ]	Average pressure to the hub
I	[kgm <sup>2</sup> ]	Moment of inertia

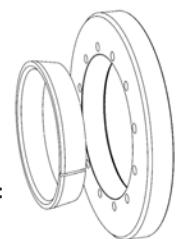
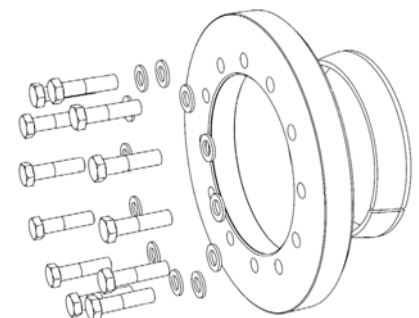
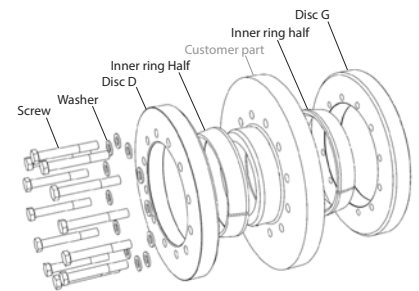

## Design of the disc

$d < 115$	Discs galvanized without washers
$d \geq 115$	Discs painted with washers

min. yield strength Rp0,2	N/mm <sup>2</sup>
Solid shaft	290
Hub	350

Dimensions H & e in unlocked position

Deviation from the standard shaft diameter  $d_w$  see the table „3091 Standard-Range“ and „Calculation of transmissible torques and forces“

Hexagon head bolts are used as standard. Upon request we provide all sized shrink discs with hexagon socket head bolts (Inbus). (See ordering information)

## For Typ in ordering information:

- GET means SPLIT
- HALB means HALF

Ordering information: TAS 3091Typ - d - y (e.g.: TAS 3091GET-200-Y60 oder TAS 3091HALB-G-200-Y30 oder TAS 3091HALB-D-200)  
with Inbus: TAS 3091Typ - d - y - Inbus (e.g.: TAS 3091GET-200-Y60-Inbus e.t.c.)

# 3091 Half/Split (Heavy-range)

**Please note:**

All values refer to shrink disk design **HALF!**

Please provide us the dimension of „y“ or the length of screws. Otherwise we can not provide appropriate screws!  
(see ordering information)

Applies to shrink disc design HALF-G:

- The required screw length is: Screw length (**3091 Heavy-Range**) -  $l_1 + 2 a + y$  (rounded up to standard lengths)

Applies to shrink disc design SPLIT:

- The design consists of **1x HALF-D + 1x HALF-G**
- Delivery is possible with or without screws
- Maximum transmittable torque:  $M_{ges} = 2 M_{max}$
- The required screw length: Screw length (**3091 Heavy-Range**) +  $2 a + y$  (rounded up to standard lengths)

											HALF-D only							
d	d <sub>w</sub>	M <sub>max</sub>	D	l	a	l <sub>1</sub>	A	B	M <sub>A</sub>	Z	d <sub>B</sub>	S	DIN	Class	n <sub>max</sub>	P <sub>N</sub>	I	Weight
mm	mm	Nm	mm	mm	mm	mm	mm	mm	Nm	Stk	mm				min <sup>-1</sup>	N/mm <sup>2</sup>	kgm <sup>2</sup>	kg
40	30	440	80	14,5	2	18	62	43	30	4	9	M 8 x 30	933	10.9	7100	249	0,0004100	0,41
44	34	670	85	16	2	19	66	47	30	5	9	M 8 x 30	933	10.9	6700	253	0,0005611	0,49
50	40	960	95	17	2	21,5	73	54	30	7	9	M 8 x 35	933	10.9	6000	233	0,0009796	0,68
55	45	1300	105	17,5	2,5	22	78	59	30	7	9	M 8 x 35	933	10.9	5400	238	0,0014752	0,84
62	50	1600	115	17,5	2,5	22	85	66	30	7	9	M 8 x 35	933	10.9	4900	235	0,0021336	1,0
68	55	1900	120	17,5	2,5	22	92	72	30	8	9	M 8 x 35	933	10.9	4700	244	0,0023780	1,0
75	60	2900	145	22	4	27	105	84	59	7	11	M 10 x 40	933	10.9	4100	257	0,0052422	1,7
80	65	3300	145	22	4	27	105	84	59	7	11	M 10 x 40	933	10.9	3900	241	0,0061706	1,8
90	70	3800	160	25	4	30	116	94	59	8	11	M 10 x 40	933	10.9	3500	220	0,0101100	2,4
100	75	4900	170	27	4	32	126	104	59	10	11	M 10 x 45	931	10.9	3300	225	0,0131288	2,7
110	80	6000	185	30	5	35	138	114	59	12	11	M 10 x 45	931	10.9	3000	216	0,0208462	3,6
120	85	7100	210	32,5	5	37,5	155	125	100	10	13,5	M 12 x 50	931	10.9	2700	219	0,0372938	5,1
125	90	7800	215	32,5	5	37,5	160	129	100	10	13,5	M 12 x 50	931	10.9	2600	210	0,0409756	5,3
140	100	10500	230	35	5	42	175	144	100	12	13,5	M 12 x 55	931	10.9	2400	207	0,0598125	6,6
155	110	14700	265	38	5	45	198	164	100	15	13,5	M 12 x 60	931	10.9	2100	212	0,1178125	10
165	120	24000	290	41	5	49	210	174	250	10	17,5	M 16 x 70	931	10.9	1900	251	0,1809031	13
175	130	26500	300	41	5	49	220	184	250	10	17,5	M 16 x 70	931	10.9	1900	237	0,2110938	14
185	140	41700	330	51	5	61	236	194	250	14	17,5	M 16 x 80	931	10.9	1700	245	0,4114844	23
200	150	47700	350	51	5	61	246	204	250	15	17,5	M 16 x 80	931	10.9	1600	243	0,5078125	25
220	165	69300	370	65	8	75	270	224	250	20	17,5	M 16 x 90	931	10.9	1500	238	0,7643625	33
240	180	90100	405	68	8	80	295	244	490	15	22	M 20 x 100	931	10.9	1400	243	1,1912	43
260	200	123000	430	76	8	88	321	265	490	18	22	M 20 x 110	931	10.9	1300	238	1,6412	52
280	220	165000	460	84	10	96	346	285	490	21	22	M 20 x 120	931	10.9	1200	237	2,3200	64
300	240	194000	485	86	10	98	364	305	490	22	22	M 20 x 120	931	10.9	1100	225	2,9270	72
320	250	214000	520	90	10	102	386	325	490	24	22	M 20 x 130	931	10.9	1100	219	3,9610	85
340	260	273000	570	98	10	110	420	345	840	21	26	M 24 x 140	931	10.9	1000	236	6,5524	119
350	280	313000	580	98	10	110	425	355	840	21	26	M 24 x 140	931	10.9	980	229	6,9409	121
360	290	343000	590	100	10	112	432	365	840	22	26	M 24 x 140	931	10.9	970	228	7,4044	124
380	305	345000	645	103	13	115	458	387	840	22	26	M 24 x 140	931	10.9	880	216	10,79	154
390	310	394000	660	107	13	119	468	397	840	24	26	M 24 x 150	931	10.9	860	220	12,34	168



# 3091 Half/Split (Heavy-Range)

											HALF-D only							
<i>d</i> mm	<i>d<sub>w</sub></i> mm	<i>M<sub>max</sub></i> Nm	<i>D</i> mm	<i>l</i> mm	<i>a</i> mm	<i>l<sub>1</sub></i> mm	<i>A</i> mm	<i>B</i> mm	<i>M<sub>A</sub></i> Nm	<i>Z</i> Stk	<i>d<sub>B</sub></i> mm	<i>S</i>	<i>DIN</i>	<i>Class</i>	<i>n<sub>max</sub></i> min <sup>-1</sup>	<i>p<sub>N</sub></i> N/mm <sup>2</sup>	<i>I</i> kgm <sup>2</sup>	<i>Weight</i> kg
400	320	408000	680	107	13	119	480	407	840	24	26	M 24 x 150	931	10.9	840	214	13,93	179
420	340	555000	690	120	13	132	504	427	840	30	26	M 24 x 160	931	10.9	830	224	16,72	205
440	350	586000	750	125	13	139	527	448	1250	24	30	M 27 x 170	931	10.9	760	215	24,76	262
460	370	741000	770	125	13	139	547	468	1250	28	30	M 27 x 170	931	10.9	740	240	27,25	271
480	390	847000	800	138	15	152	580	488	1250	30	30	M 27 x 180	931	10.9	710	224	35,25	324
500	410	955000	850	138	15	152	600	508	1250	32	30	M 27 x 180	931	10.9	670	229	45,34	373
530	440	1103000	910	152,5	15	166,5	630	538	1250	34	30	M 27 x 200	931	10.9	630	206	65,15	470
660	540	2058000	1070	170	15	185	780	670	2800	30	39	M 36 x 240	931	10.9	530	224	132	666



**TAS**  
**SCHÄFER**



# 3093 Heavy-Range (strengthened)

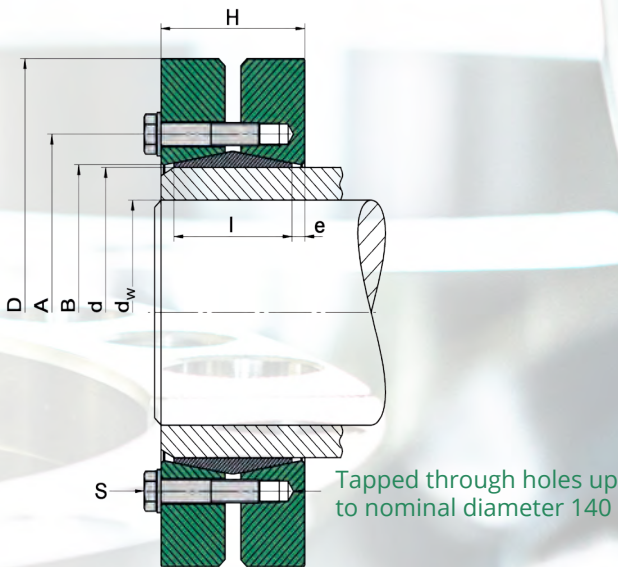

## Used symbols

d	[mm]	Nominal diameter of the shrink disc
$d_w$	[mm]	Shaft diameter
$M_{max}$	[Nm]	Maximal transmittable torque
D	[mm]	Outer diameter
l	[mm]	Length of the inner ring
e	[mm]	Excess length
H	[mm]	Width of the shrink disc
A	[mm]	Pitch circle diameter
B	[mm]	Attachment size
$M_A$	[Nm]	Tightening torque of the clamping screws
Z		Number of clamping screws
S		Size of the clamping screws
$n_{max}$	[min <sup>-1</sup> ]	Permitted rotational frequency
$p_N$	[N/mm <sup>2</sup> ]	Average pressure to the hub
I	[kgm <sup>2</sup> ]	Moment of inertia

## Design of the disc

$d < 115$	Discs galvanized without washers
$d \geq 115$	Discs painted with washers

Dimensions H & e in unlocked position

Hexagon head bolts are used as standard. Upon request we provide all sized shrink discs with hexagon socket head bolts (Inbus). (See ordering information)

## Variation from the standard shaft diameter $d_w$

> mm	≤ mm	minimal - mm	maximal + mm
40	50	-3	2
50	140	-5	5
140	180	-10	5
180	320	-15	10
320	440	-20	10
440	600	-30	10

$$M = M_{max(Catalog)} \left( \frac{d_w(target)}{d_w(Catalog)} \right)^2$$

(see Basics - Calculation)

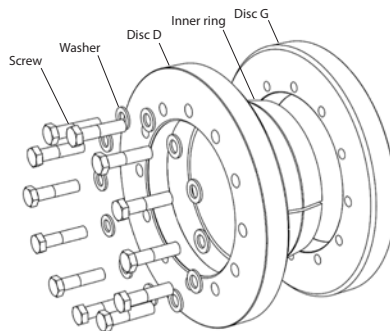

min. yield strength Rp0,2	N/mm <sup>2</sup>
Solid shaft	350
Hub	450

Ordering information: TAS 3093 - d (e.g.: TAS 3093-200 ... further sizes on request)  
with Inbus: TAS 3093 - d - Inbus (e.g.: TAS 3093-200-Inbus)



# 3093 Heavy-Range (strengthened)

<b>d</b> mm	<b>d<sub>w</sub></b> mm	<b>M<sub>max</sub></b> Nm	<b>D</b> mm	<b>l</b> mm	<b>e</b> mm	<b>H</b> mm	<b>A</b> mm	<b>B</b> mm	<b>M<sub>A</sub></b> Nm	<b>Z</b> Stk	<b>S</b>	<b>DIN</b>	<b>Class</b>	<b>n<sub>max</sub></b> min <sup>-1</sup>	<b>p<sub>N</sub></b> N/mm <sup>2</sup>	<b>I</b> kgm <sup>2</sup>	<b>Weight</b> kg
40	30	1000	80	25	3,5	32	62	43	35	4	M 8 x 30	933	12.9	7100	291	0,0008300	0,83
44	34	1600	85	28	3	34	66	47	35	5	M 8 x 30	933	12.9	6700	295	0,0011451	1,0
55	45	3500	105	30	4,5	39	78	59	35	7	M 8 x 35	933	12.9	5400	309	0,0029856	1,7
62	50	3800	115	30	4,5	39	85	66	35	7	M 8 x 35	933	12.9	4900	274	0,0042672	2,0
68	55	4700	120	30	4,5	39	92	72	35	8	M 8 x 35	933	12.9	4700	285	0,0049938	2,1
75	60	7200	145	36	5	46	105	84	69	7	M 10 x 40	933	12.9	4100	300	0,0101760	3,3
80	65	8000	145	36	5	46	105	84	69	7	M 10 x 40	933	12.9	3900	282	0,0123412	3,6
90	70	9100	160	40	5	50	116	94	69	8	M 10 x 40	933	12.9	3500	258	0,0202200	4,8
100	75	11800	170	44	5	54	126	104	69	10	M 10 x 45	931	12.9	3300	263	0,0262575	5,4
110	80	14500	185	50	5	60	138	114	69	12	M 10 x 45	931	12.9	3000	253	0,0411134	7,1
120	85	17500	210	55	5	65	155	125	120	10	M 12 x 50	931	12.9	2700	257	0,0731250	10
125	90	19000	215	55	5	65	160	129	120	10	M 12 x 50	931	12.9	2600	246	0,0850438	11
140	100	25600	230	60	7	74	175	144	120	12	M 12 x 55	931	12.9	2400	242	0,1178125	13
155	110	35800	265	66	7	80	198	164	120	15	M 12 x 60	931	12.9	2100	248	0,2356250	20
165	120	57800	290	72	8	88	210	174	290	10	M 16 x 65	931	12.9	1900	295	0,3757219	27
175	130	63800	300	72	8	88	220	184	290	10	M 16 x 65	931	12.9	1900	278	0,4221875	28
185	140	99900	330	92	10	112	236	194	290	14	M 16 x 80	931	12.9	1700	288	0,8229688	46
200	150	114000	350	92	10	112	246	204	290	15	M 16 x 80	931	12.9	1600	285	1,0359	51
220	165	166000	370	114	10	134	270	224	290	20	M 16 x 90	931	12.9	1500	279	1,5287	66
240	180	213000	405	120	12	144	295	244	570	15	M 20 x 100	931	12.9	1400	284	2,3548	85
260	200	294000	430	136	12	160	321	265	570	18	M 20 x 110	931	12.9	1300	277	3,2825	104
280	220	390000	460	148	12	172	346	285	570	21	M 20 x 120	931	12.9	1200	276	4,6400	128
300	240	458000	485	152	12	176	364	305	570	22	M 20 x 120	931	12.9	1100	263	5,8100	143
320	250	506000	520	160	12	184	386	325	570	24	M 20 x 130	931	12.9	1100	255	7,9200	170
340	260	648000	570	176	12	200	420	345	980	21	M 24 x 130	931	12.9	1000	276	13,10	238
350	280	741000	580	176	12	200	425	355	980	21	M 24 x 130	931	12.9	980	268	13,94	243
360	290	812000	590	180	12	204	432	365	980	22	M 24 x 140	931	12.9	970	267	14,81	248
380	305	850000	645	180	12	204	458	387	980	22	M 24 x 140	931	12.9	880	253	21,65	309
390	310	934000	660	188	12	212	468	397	980	24	M 24 x 140	931	12.9	860	257	24,68	336
420	340	1312000	690	214	12	238	504	427	980	30	M 24 x 150	931	12.9	830	262	33,52	411
440	350	1388000	750	224	14	252	527	448	1450	24	M 27 x 170	931	12.9	760	251	49,52	524
460	370	1752000	770	224	14	252	547	468	1450	28	M 27 x 170	931	12.9	740	280	54,40	541
480	390	2001000	800	246	14	274	580	488	1450	30	M 27 x 180	931	12.9	710	262	70,39	647
500	410	2256000	850	246	14	274	600	508	1450	32	M 27 x 180	931	12.9	670	268	90,81	747
530	440	2607000	910	275	14	303	630	538	1450	34	M 27 x 200	931	12.9	630	241	130	939
660	540	4897000	1070	310	15	340	780	670	3300	30	M 36 x 240	931	12.9	530	264	263	1331

# Typ 52 shrink Discs matching Stiebel - helical-bevel gears

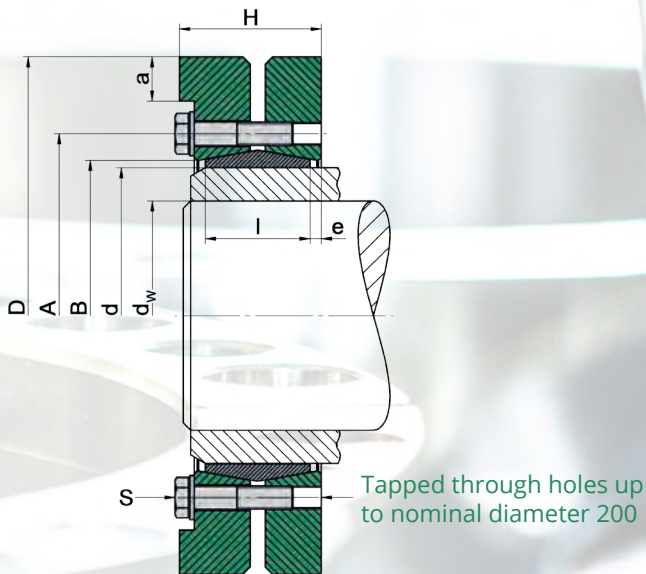

## Used symbols

d	[mm]	Nominal diameter of the shrink disc
$d_w$	[mm]	Shaft diameter
$M_{max}$	[Nm]	Maximal transmittable torque
D	[mm]	Outer diameter
l	[mm]	Length of the inner ring
e	[mm]	Excess length
H	[mm]	Width of the shrink disc
A	[mm]	Pitch circle diameter
B	[mm]	Attachment size
$M_A$	[Nm]	Tightening torque of the clamping screws
Z		Number of clamping screws
S		Size of the clamping screws
$n_{max}$	[min <sup>-1</sup> ]	Permitted rotational frequency
$p_N$	[N/mm <sup>2</sup> ]	Average pressure to the hub
I	[kgm <sup>2</sup> ]	Moment of inertia

## Design of the disc

$d < 115$	Discs galvanized without washers
$d \geq 115$	Discs painted with washers

Dimensions H & e in unlocked position

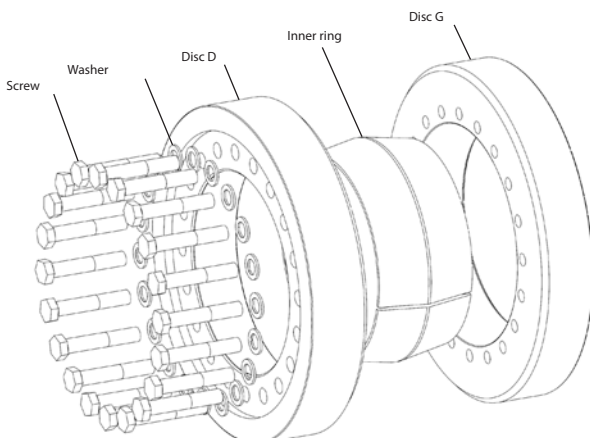

min. yield strength Rp0,2	N/mm <sup>2</sup>
Solid shaft	290
Hub	350

Order information: TAS Typ (z.B.: TAS 5226 ... further sizes on request)

# Typ 52 shrink Discs matching Stiebel – helical-bevel gears

Typ	d mm	d <sub>w</sub> mm	M <sub>max</sub> Nm	D mm	l mm	e mm	H mm	a mm	A mm	B mm	M <sub>A</sub> Nm	Z Stk	S	DIN	Class	n <sub>max</sub> min <sup>-1</sup>	p <sub>N</sub> N/mm <sup>2</sup>	I kgm <sup>2</sup>	Weight kg
5206	50	40	1200	90	22	2,75	31,5	2	70	53	12	8	M 6 x 25	931	10.9	6300	217	0,0010600	0,8
5208	62	50	2100	110	23	4,25	35,5	3	86	66	12	10	M 6 x 25	931	10.9	5200	210	0,0025909	1,3
5210	75	60	3600	138	25	3,75	38	8	100	79	30	7	M 8 x 30	931	10.9	4100	233	0,0070923	2,3
5212	88	70	6300	155	30	4,5	44,5	9,5	114	94	30	10	M 8 x 35	931	10.9	3600	236	0,0135018	3,4
5214	90	75	7300	155	30	4,5	44,5	9,5	114	94	30	10	M 8 x 35	931	10.9	3600	231	0,0132516	3,3
5216	110	85	10000	185	39	5,5	57	9,5	136	114	59	9	M 10 x 40	931	10.9	3000	208	0,0347437	6,0
5218	138	100	18300	230	46	7,25	68,5	10	175	146	100	10	M 12 x 45	931	10.9	2400	228	0,0989230	11
5220	155	120	30000	265	50	7,25	72,5	19	192	165	100	12	M 12 x 50	931	10.9	2100	224	0,1885000	16
5222	165	120	38700	290	56	7,5	81	20	210	175	250	8	M 16 x 55	931	10.9	1900	258	0,3061438	22
5224	175	135	58400	300	72	8	98	20	220	184	250	10	M 16 x 65	931	10.9	1900	237	0,4221875	28
5226	200	150	95400	350	92	10	122	30	246	204	250	15	M 16 x 80	931	10.9	1600	243	1,0359	51
5228	220	170	149000	370	114	10	144	27,5	270	224	250	20	M 16 x 90	931	10.9	1500	238	1,5287	66

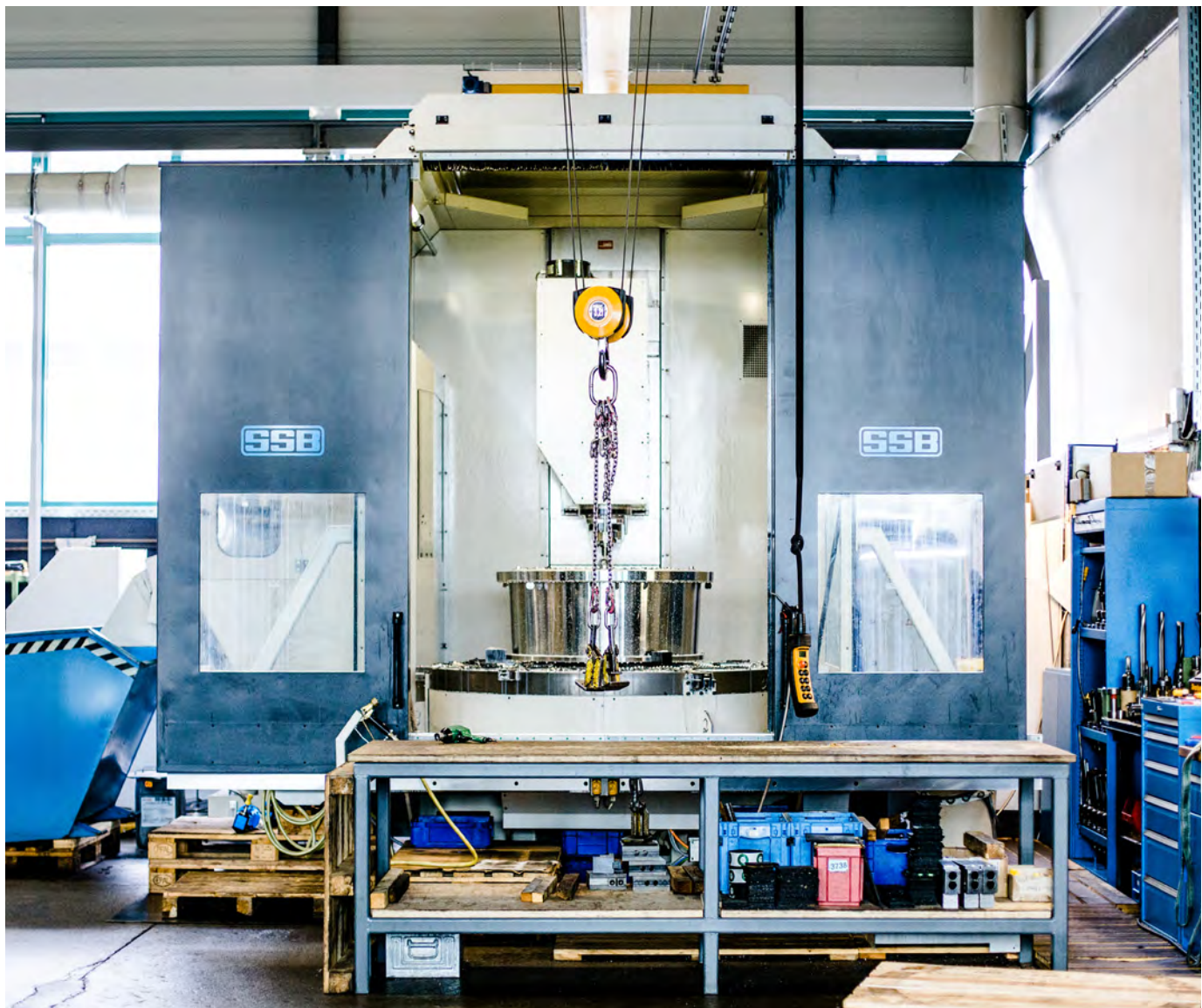



**TAS**  
**SCHÄFER**



# Flange Coupling

Connecting flange, rigid connection



# Description of function FK

## Rigid flange coupling with three-parted shrink disc of the type TAS 30..

The main function of the rigid flange coupling (FK) is the safe and backlash-free connection of two shafts by means of friction. For example, between a drive shaft and an agitator shaft. Flange couplings are directly separable at the flanges. The used shrink discs generate a backlash-free connection by pressing the flange-hubs onto the shafts. This connection is mainly used to transmit torque.

The shrink discs do not transmit any forces and/or moments between the shafts and hubs, they just provide the necessary forces. They are not in the flow of forces.

It is installed by sliding the flanges onto the shaft ends and subsequent tightening of the shrink disc. Thereafter the flanges are connected by bolting.

The rigid flange couplings are supplied ready for installation.

To achieve proper operation and a sufficiently high coefficient of friction, the contact surfaces between the shaft extensions and flange-hubs, as well as the contact surfaces of the flanges, must be free of grease, dry and clean. The functional surfaces of the shrink disc, threads and head rests of the screws are provided at the factory with lubricant. The contact surfaces between the flange-hubs and shrink discs are oiled.

A detailed installation manual is available on the Internet.

### Product data

#### Data sheets

- Contact us if a data sheet for an individual product is required.

For CAD data of flange couplings, contact us directly, please.

**Rolf Gertner**  
rolf.gertner@tas-schaefer.de

or

**Mike Kemper**  
mike.kemper@tas-schaefer.de

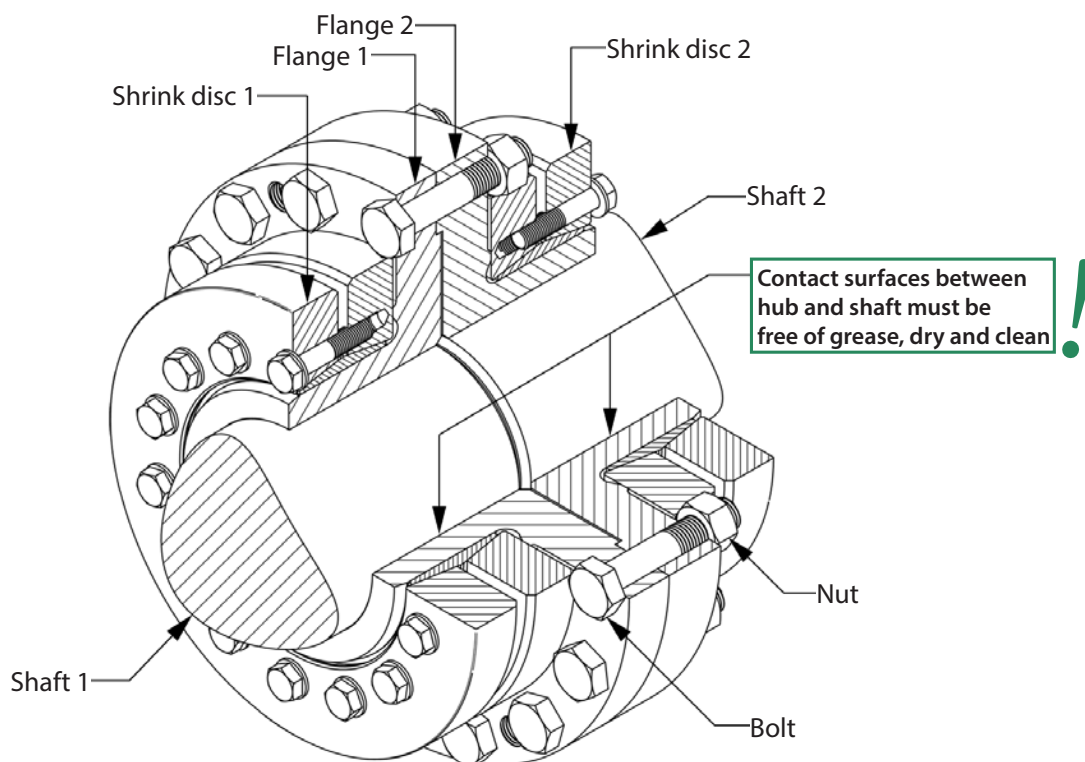

# Basics - Calculation FK

## Advantages and differences to other systems

- **Use of shrink discs / flow of forces**

Due to the use of shrink discs, the forces and moments are transferred directly between the shaft and flange. In comparison with internal clamping systems the achievable runout accuracy is higher.

- **Pursue the same diameter - but an adaptation to different diameters is also possible**

Basically the target should be to connect shaft ends of the same size. With larger deviations the flange-hubs can be adapted for the different diameters. This is done by using different shrink discs.

- **Tightening torque of the clamping screws**

When using different shrink discs and shaft diameters, the tightening torque and therefore the clamping forces of the shrink discs are adjustable. For example, this is also possible with soft shaft materials and reduces, if required, the stresses in the components.

- **Positioning**

The cylindrical connection, as well as the used clearance, allows an easy and precise positioning of the flanges on the shaft ends. During the clamping process there is no more shift.

- **Short length (B version)**

The design „B“, with clamping the shrink discs through the flange face, provides a very short mounting length, as there is no extra space needed behind the coupling.

- **No hydraulic necessary**

A hydraulic expansion of the hubs is not necessary for mounting.

- **No heating necessary**

There is no need for expansion of the hubs by heating. To increase the clearance between the shaft and flange, a slight warming is possible.

- **Shafts with keyways**

The couplings can be used on shafts with keyways. As far as possible, the keyways should be closed.

- **Tolerances and surfaces**

The values found in the product data, are based on surface quality and tolerances, according to the table below. These values are given as recommendations.

Higher values for the surface roughness reduce the transmissible torque and promote unwanted settling.

Larger clearance also reduces the transmissible torque and increases stresses in the flange-hub.

**If you have different shaft tolerances, please let us know. Then we can adjust the bores in the flanges accordingly!**

Recommended tolerances and surface roughness				
>	≤	FS <sub>max</sub> mm	Clearance Hub / Shaft	Rz µm
9	18	0,022	H6/h6	10
18	30	0,026	H6/h6	10
30	50	0,032	H6/h6	10
50	80	0,049	H7/h6	10
80	120	0,057	H7/h6	16
120	150	0,065	H7/h6	16
150	180	0,079	H7/g6	16
180	250	0,090	H7/g6	16
250	315	0,101	H7/g6	16
315	400	0,111	H7/g6	16
400	500	0,123	H7/g6	25
500	630	0,136	H7/g6	25
630	800	0,154	H7/g6	25
800	1000	0,172	H7/g6	25



# Basics - Calculation FK

The calculation of the values, given in the catalogue, are based on the following assumptions and simplifications:

## Distinction flange connection / shrink disc

Due to the design, the transmissible forces and torque, are to look separately for the shrink disc and the flange. While the shrink disc provides clamping forces only, the transmissible forces and torque must be accommodated by the flange. This results in different values for shrink connection and flange.

## Transmissible torque at the shrink disc

A shrink disc connection is capable of transmitting torque, bending moment and axial force. Substituted, the transmissible torque  $M_{max}$  is specified in the product data. If such loads occur simultaneously then they must be added vectorially to the resultant moment  $M_{res}$ . The formula below applies to the resulting moment:

$$M_{res} \leq M_{max}$$

At different load cases, they must be individually checked against  $M_{max}$  !

$M_{res}$  is determined for combined loads as follows:

$$M_{res} = \sqrt{M_T^2 + 2M_B^2 + (F_{AX} \frac{d_W}{2})^2}$$

with  $M_B \leq 0,3 M_{max}$   
as the limit \* for the bending moment

\*In principle, the maximum bending moment corresponds to the maximum transmittable torque. The limitation to  $0,3 M_{max}$  is due to the change of the surface pressure at the edges of the connection.  
(This information applies to the shrink connection only!)

## This results in the following relationships:

### Nur Drehmoment:

The maximum torque is equivalent to  $M_{max}$ .

### Nur Biegemoment:

The maximum static bending moment corresponds to  $0,4 M_{max}$ .

## Axial force only :

The maximum axial force is  $M_{max} \frac{2}{d_W}$

In addition, the load on the flange bolting connection must be taken into account

Transmissible forces and torque at the flange connection

The bolt connection of the flanges is also based on friction. The torque is transmitted via this connection. Whereas the torque capacity usually corresponds to, or is higher than that of the shrink connection it is any transmissible bending moment which must be particularly considered.

Bending influences the bolt connections and the flange itself. The static load case usually corresponds to the transmissible bending moment of the shrink connection, the bending moment capacity is however lower in the dynamic load and will be determined for each individual case by us (refer to the Product questionnaire).

The same applies to axial loads, as they are transmitted directly by the bolt connection of the flanges.

## Static and dynamic load

For some applications, a static review of the coupling is sufficient. The clamping forces of the shrink connection are static. Non cyclic torques and/or axial forces can also be considered as static loads. Rotating bending has to be considered as a dynamic load and the coupling must be calculated accordingly. Therefore it is also essential to specify the actual occurring load cases.

## Shaft and hub calculation

The flange-hub will be deformed due to the applied clamping force. Shaft stiffness and surface finish should be considered in addition to the clearance between shaft and hub. Stiffness can be ignored for solid shafts, but for hollow shafts (see „Bore in the shaft (hollow shaft)“) there is higher deformation and thus higher stresses in the components. This must be considered in addition to other loads.

The stresses in the hub can be determined by various hypotheses, such as GEH. A discussion and analysis of results is not made here because only a very limited range of static applications could be covered. Various calculation methods for different cases can be found in engineering literature or using specialised software. Often only a calculation via FEA will give reliable results for complex geometry

## Notch effect

Generally there is a notch effect on the components caused by the radial pressure of the pressure ring. This depends mainly on the applied pressure. The notch effect is generally higher on the hub than on the shaft, because the pressure ring is directly pressed onto the hub, while the stresses are distributed through the hub before reaching the shaft. The notch factors range from 2,5 to 3,5 for the hub and between 1,5 and 2 for the shaft. This can be mitigated by suitable design features, such as relief notches.

Some standards provide the possibility for a notch factor to be determined by a fit pairing (interference fit) for a shrink-connection. A similar method can also be used for such shrink connections. To this end an oversize can be calculated from the applied surface pressures. As a result a matching fit pair can be determined and thus a resultant notch factor found.

## Bore in the shaft (hollow shaft)

A large bore  $d_B$  in the shaft or the use of a hollow shaft, reduces the stiffness of the shaft against radial pressure. This leads to a decrease in pressure  $p_W$ , a reduced transmissible torque  $M$ , a contraction  $\Delta d_B$  within the shaft and an increase of stresses in these components. Basically, a bore should not be greater than  $0,3 d_W$ .

# Rigid Flange Coupling FK/FKB

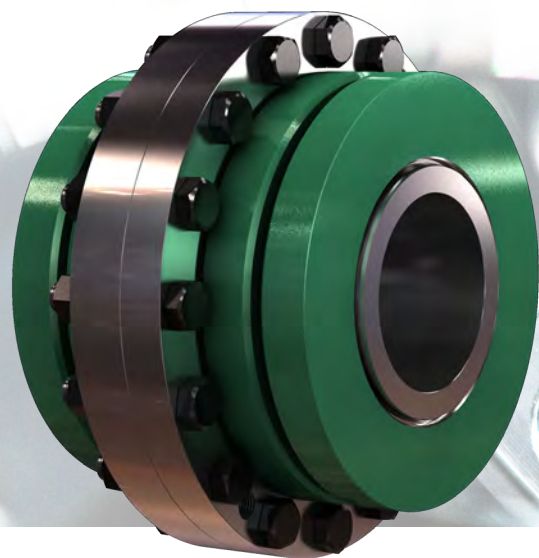
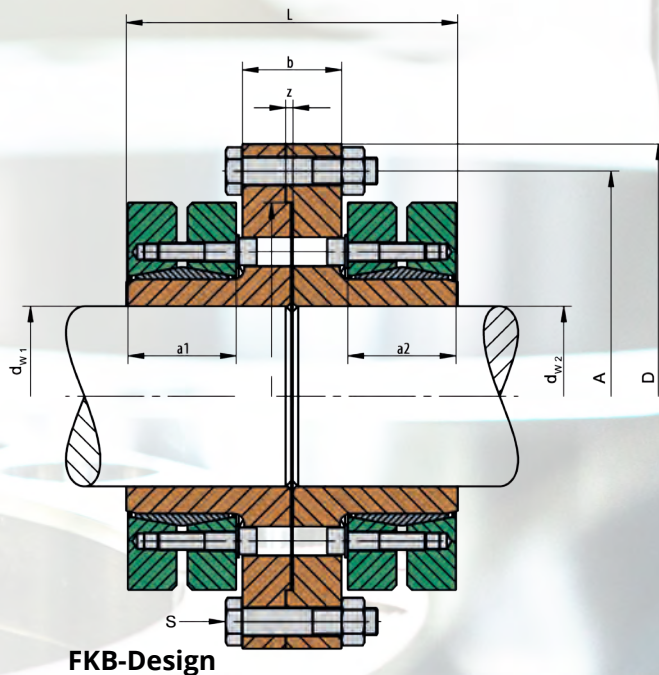

## Used symbols

<i>FK</i>		Nominal size
$d_{w1}$ & $d_{w2}$ [mm]		Shaft diameters
$M_{tmax}$ [Nm]		Maximal transmittable torque (depends on used shrink disc and $d_w$ )
<i>A</i> [mm]		Pitch circle diameter
<i>D</i> [mm]		Outer diameter
$D_z$ [mm]		Diameter of the flange centering
<i>L</i> [mm]		Width of the flange coupling
<i>a</i> [mm]		Width of the shrink disc
<i>b</i> [mm]		Thickness of flange
<i>z</i> [mm]		Depth of the centering
<i>I</i> [kgm <sup>2</sup> ]		Moment of inertia
<b>Bolts</b>		
<i>Z</i>		Number
<i>S</i>		Size
$M_A$ [Nm]		Required tightening torque

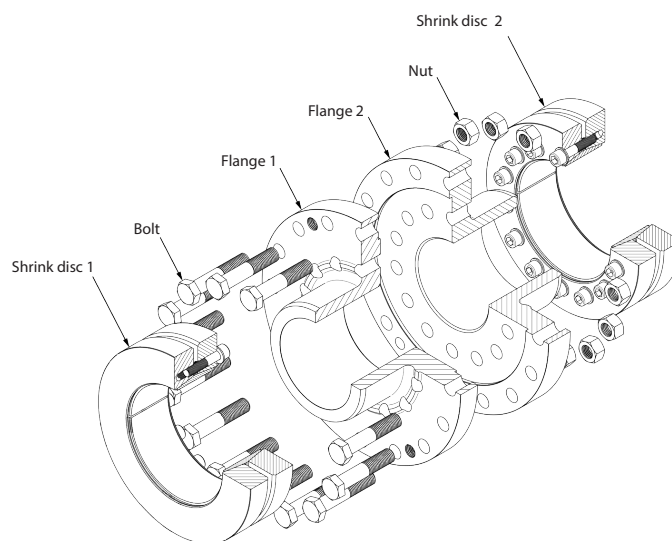

# Rigid Flange Coupling FK/FKB

FK	d <sub>w</sub> mm	M <sub>t max</sub> Nm	Shrink disc		Dimensions							Flange bolts			I kgm <sup>2</sup>	Weight kg
			Type 3071-d	M <sub>A</sub> Nm	A mm	D mm	D <sub>z</sub> mm	L mm	a mm	b mm	z mm	Z Stk	S	M <sub>A</sub> Nm		
75	75	7300	100	30	210	240	170	136	44	44	4	6	M 16 x 70	210	0,165499	26
90	90	13100	125	59	265	305	215	160	54	48	5	6	M 20 x 80	420	0,487699	48
100	100	17900	140	100	286	340	230	190	64	56	5	5	M 24 x 90	720	0,829143	63
120	120	38700	165	250	356	400	300	228	75	72	5	8	M 24 x 110	720	2,126131	120
130	130	42600	175	250	356	400	300	228	75	72	5	8	M 24 x 110	720	2,246611	120
150	150	79500	195	250	420	475	350	278	90	90	6	10	M 30 x 130	1450	5,408399	215
165	165	103000	220	250	440	510	370	314	108	90	6	14	M 30 x 130	1450	7,692146	270
180	180	144000	240	490	475	540	405	322	113	88	6	16	M 30 x 130	1450	10,247074	310
200	200	193000	<sup>(1)</sup> 260	490	500	560	430	368	125	110	8	16	M 30 x 150	1450	14,889123	395
220	220	251000	280	490	530	590	460	392	139	104	8	18	M 30 x 150	1450	18,392262	445
240	240	318000	300	490	555	615	485	408	147	104	8	20	M 30 x 150	1450	22,627586	500
260	260	435000	340	490	640	710	570	450	161	118	8	24	M 30 x 160	1450	45,880687	780
290	290	519000	360	490	660	720	590	450	167	106	8	24	M 30 x 150	1450	76,117692	790
310	310	697000	390	840	735	805	660	484	180	114	8	28	M 30 x 160	1450	81,558246	1060
340	340	891000	420	840	770	835	690	530	198	122	10	30	M 30 x 160	1450	102,442438	1230
380	380	1198000	460	840	845	920	770	556	208	128	10	35	M 30 x 170	1450	166,038502	1420
410	410	1431000	500	1250	940	1030	850	618	225	156	12	32	M 36 x 200	2400	283,051874	2200
440	440	1961000	530	1250	1000	1100	900	696	258	160	14	36	M 36 x 200	2400	382,170457	2680
470	470	2397000	590	1250	1080	1180	980	744	280	164	14	40	M 36 x 200	2400	553,092493	3340
500	500	2742000	620	1250	1110	1210	1020	744	280	164	14	42	M 36 x 200	2400	638,288490	3620

<sup>(1)</sup> 3071.4

## How to order (product identification)

T A S F K B S - 0 9 0 / 1 0 0 / 1 0 0 - 0 0 0 1

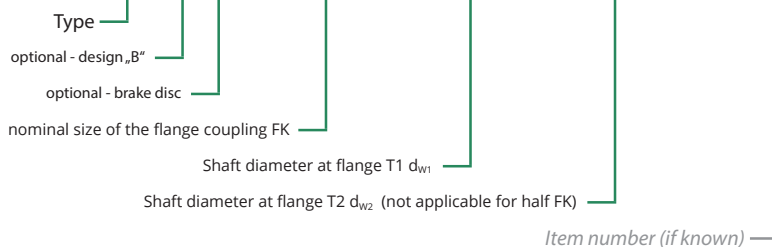

Includes reference to:  
Type of shrink discs  
Size of shrink discs  
Toleranced dimensions  
Tightening torques

## Examples:

TAS FK-090/085/095

Flange coupling in nominal size FK = 090 / d<sub>w1</sub> = Ø85 / d<sub>w2</sub> = Ø95

TAS FKB-090/085/095

Flange coupling design „B“ in nominal size FK = 090 / d<sub>w1</sub> = Ø85 / d<sub>w2</sub> = Ø95

TAS FKS-090/085/095

Flange coupling with brake disc in nominal size FK = 090 / d<sub>w1</sub> = Ø85 / d<sub>w2</sub> = Ø95

TAS FKBS-090/085/095

Flange coupling design „B“ with brake disc in nominal size FK = 090 / d<sub>w1</sub> = Ø85 / d<sub>w2</sub> = Ø95



# Description of function FKE

## Rigid flange coupling with pressure ring

The main function of the rigid flange coupling (FKE) is the safe and backlash-free connection of two shafts by means of friction. For example, between a drive shaft and an agitator shaft. Flange couplings are directly separable at the flanges. The pressure ring generates a backlash-free connection by pressing the flange-hub onto the shaft. This connection is mainly used to transmit torque. It can also transmit axial forces and bending moments.

The shrink connection itself does not transmit any forces and/or moments between the shaft and hub, it just provides the necessary forces between the two. The shrink connection is not part of the flow of forces.

Installation is by sliding the flanges onto the shaft ends and subsequently tightening of the pressure ring. Thereafter the flanges are connected by a second series of bolts.

The rigid flange couplings are supplied ready for installation. The clamping is achieved manually by means of a torque wrench. Optionally a hydraulic clamping tool can be used.

To achieve proper operation and a sufficiently high coefficient of friction, the contact surfaces between the shaft extension and flange-hub, as well as the contact surfaces of the flange, must be free of grease, dry and clean. The functional surfaces of the cones, threads and head seats of the

bolts are supplied at the factory lubricated.

A detailed installation manual is available on the Internet. ([www.tas-schaefer.de](http://www.tas-schaefer.de))

### Product data

#### Data sheets

- Contact us if a data sheet for an individual product is required.

Contact us for CAD data of flange couplings. These are provided upon request.

**Rolf Gertner**  
rolf.gertner@tas-schaefer.de

or

**Mike Kemper**  
mike.kemper@tas-schaefer.de

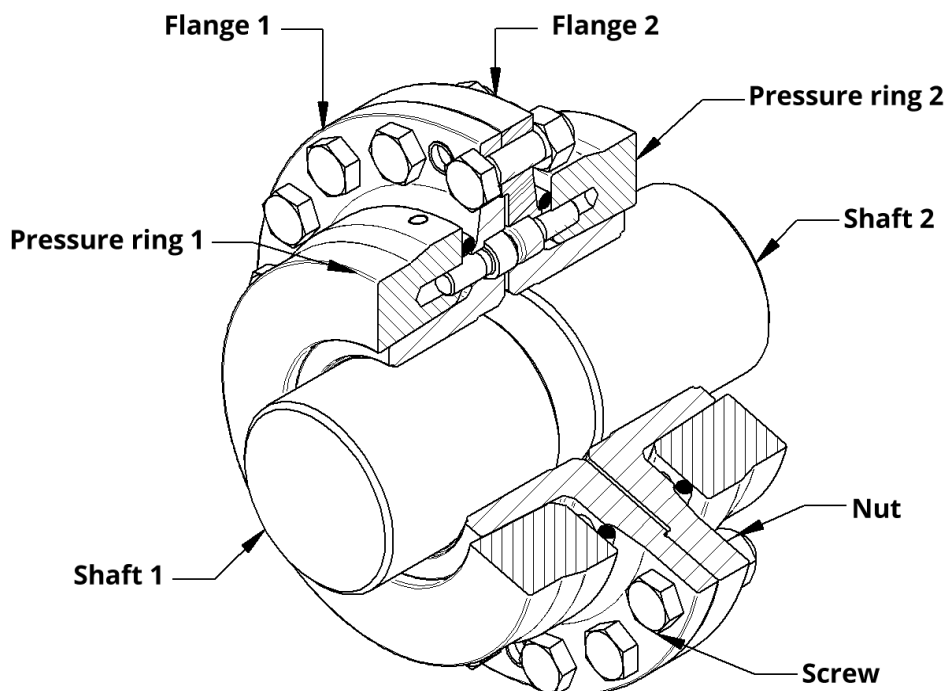

# Basics - Design FKE

## Advantages and differences compared to other systems

- **Use of pressure rings / flow of forces**

Forces and moments are transferred directly between the shaft and flange due to the use of the pressure ring. The achievable runout accuracy is higher compared to internal clamping systems.

Similar shaft diameters preferred - but an adaptation to different diameters is also possible

Basically, the goal should be to connect shaft ends of the similar size. Flange hubs can however be adapted to larger shaft diameter differences. This is done by using different pressure rings and adapting the flanges.

- **Tightening torque of the clamping screws**

The tightening torque and therefore the clamping forces can be adjusted when using different pressure rings and shaft diameters. As an example, it is also possible to use soft shaft materials reducing the stresses in the components.

- **Positioning**

The cylindrical shaft connection and the clearance fit allow for an easy and precise positioning of the flanges on the shaft ends. During the clamping process there is no shifting of the shaft.

- **Short length**

The clamping of the pressure ring through the flange face provides a design with a very short mounting length, as no extra space is needed behind the coupling.

- **No hydraulic necessary**

Hydraulic expansion of the hubs is not necessary for mounting.

- **No heating necessary**

There is no need for expansion of the hubs by heating. A slight warming of the hub is possible to increase the clearance between the shaft and flange.

- **Shafts with keyways**

The couplings can be used on shafts with keyways. As far as possible, the keyways should be closed.

- **Tolerances and surfaces**

The values found in the product datasheet, are based on specific surface qualities and tolerances according to the table below. These values are given as recommendations.

Higher surface roughness reduces the transmissible torque and can lead to unwanted settling.

Larger clearance also reduces the transmissible torque and increases stresses in the flange-hub.

Please advise if different shaft tolerances are required. The bore tolerances can then be adjusted accordingly!

Recommended tolerances and surface roughness

>	≤	FS <sub>max</sub> mm	Clearance Hub / Shaft	Rz µm
9	18	0,022	H6/h6	10
18	30	0,026	H6/h6	10
30	50	0,032	H6/h6	10
50	80	0,049	H7/h6	10
80	120	0,057	H7/h6	16
120	150	0,065	H7/h6	16
150	180	0,079	H7/g6	16
180	250	0,090	H7/g6	16
250	315	0,101	H7/g6	16
315	400	0,111	H7/g6	16
400	500	0,123	H7/g6	25
500	630	0,136	H7/g6	25
630	800	0,154	H7/g6	25
800	1000	0,172	H7/g6	25

# Basics - Calculation FKE

The calculation of the values, given in the catalogue, are based on the following assumptions and simplifications:

## Distinction between flange connection & pressure ring

The transmissible forces and torque are considered separately for the pressure ring and the flange due to the coupling design. While the pressure ring provides clamping forces only, the transmissible forces and torque must be accommodated by the flange. This results in different values for the shrink connection and the flange.

## Transmissible torque

A shrink connection is capable of transmitting torque, bending moment and axial force. The transmissible torque  $M_{\max}$  is specified in the product data as a sole parameter. If additional loads occur simultaneously then they must be added vectorially to the resultant moment  $M_{\text{res}}$ . The formula below applies to the resulting moment:

$$M_{\text{res}} \leq M_{\max}$$

Each different load case must be individually checked against  $M_{\max}$  !

$M_{\text{res}}$  is determined for combined loads as follows:

$$M_{\text{res}} = \sqrt{M_T^2 + 2M_B^2 + (F_{\text{AX}} \frac{d_W}{2})^2}$$

with  $M_B \leq 0,4 M_{\max}$   
as the limit\* for the  
static bending moment

\*In principle, the maximum bending moment corresponds to the maximum transmissible torque. The limitation of  $0,4 M_{\max}$  is due to the change of the surface pressure at the edges of the connection. (This information applies to the shrink connection of the coupling only!)

## This results in the following relationships:

### Torque only:

The maximum torque is equivalent to  $M_{\max}$  .

### Bending moment only:

The maximum static bending moment corresponds to  $0,4 M_{\max}$  .

### Axial force only:

The maximum axial force is

$$M_{\max} \frac{2}{d_W} .$$

In addition, the load on the flange bolting connection must be taken into account

## Transmissible forces and torque at the flange connection

The bolt connection of the flanges is also based on friction. The torque is transmitted via this connection. Whereas the torque capacity usually corresponds to, or is higher than that of the shrink connection it is any transmissible bending moment which must be particularly considered.

Bending influences the bolt connections and the flange itself. The static load case usually corresponds to the transmissible bending moment of the shrink connection, the bending moment capacity is however lower in the dynamic load and will be determined for each individual case by us (refer to the Product questionnaire).

The same applies to axial loads, as they are transmitted directly by the bolt connection of the flanges.

## Static and dynamic load

For some applications, a static review of the coupling is sufficient. The clamping forces of the shrink connection are static. Non cyclic torques and/or axial forces can also be considered as static loads. Rotating bending has to be considered as a dynamic load and the coupling must be calculated accordingly. Therefore it is also essential to specify the actual occurring load cases.

## Shaft and hub calculation

The flange-hub will be deformed due to the applied clamping force. Shaft stiffness and surface finish should be considered in addition to the clearance between shaft and hub. Stiffness can be ignored for solid shafts, but for hollow shafts (see „Bore in the shaft (hollow shaft)“) there is higher deformation and thus higher stresses in the components. This must be considered in addition to other loads.

The stresses in the hub can be determined by various hypotheses, such as GEH. A discussion and analysis of results is not made here because only a very limited range of static applications could be covered. Various calculation methods for different cases can be found in engineering literature or using specialised software. Often only a calculation via FEA will give reliable results for complex geometry

## Notch effect

Generally there is a notch effect on the components caused by the radial pressure of the pressure ring. This depends mainly on the applied pressure. The notch effect is generally higher on the hub than on the shaft, because the pressure ring is directly pressed onto the hub, while the stresses are distributed through the hub before reaching the shaft. The notch factors range from 2,5 to 3,5 for the hub and between 1,5 and 2 for the shaft. This can be mitigated by suitable design features, such as relief notches.

Some standards provide the possibility for a notch factor to be determined by a fit pairing (interference fit) for a shrink-connection. A similar method can also be used for such shrink connections. To this end an oversize can be calculated from the applied surface pressures. As a result a matching fit pair can be determined and thus a resultant notch factor found.

## Bore in the shaft (hollow shaft)

A large bore  $d_B$  in the shaft or the use of a hollow shaft, reduces the stiffness of the shaft against radial pressure. This leads to a decrease in pressure  $p_W$ , a reduced transmissible torque  $M$ , a contraction  $\Delta d_B$  within the shaft and an increase of stresses in these components. Basically, a bore should not be greater than  $0,3 d_W$  .



# Rigid Flange Coupling FKE

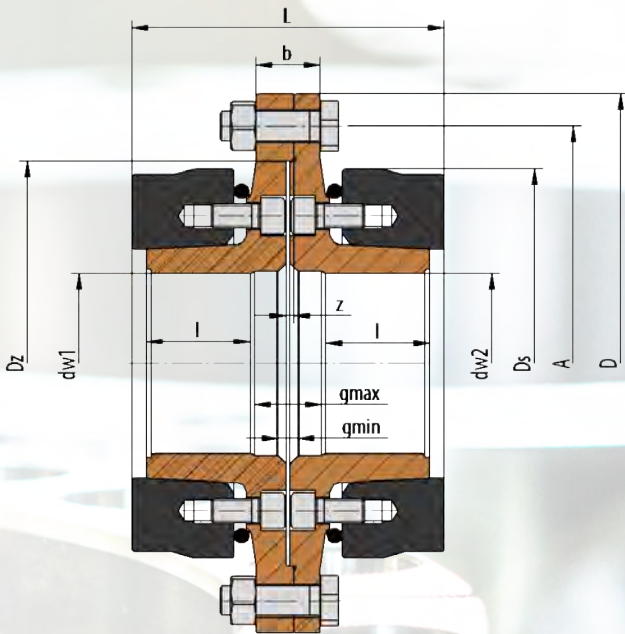

## Used symbols

FKE		Nominal size
$d_w$	[mm]	Shaft diameters
$M_{t_{max}}$	[Nm]	Maximum transmittable torque
$M_{bs_{max}}$	[Nm]	Maximum transferable bending moment (static)
$M_{bd_{max}}$	[Nm]	Maximum transferable bending moment (dynamic)
$D_s$	[mm]	Outer diameter of pressure ring
Z	[Stk.]	Number of clamping screws
S		Screw size of clamping screws
$M_A$	[Nm]	Required tightening torque for clamping screws
A	[mm]	Pitch circle diameter of connecting screws
D	[mm]	Outer diameter of the flange coupling
$D_z$	[mm]	Diameter of the flange recess
L	[mm]	Width of the flange coupling
l	[mm]	Clamping length
$g_{min}$	[mm]	Minimum shaft distance
$g_{max}$	[mm]	Maximum shaft distance
b	[mm]	Thickness of flanges
z	[mm]	Depth of the recess
$Z_F$	[Stk.]	Number of connecting screws
$S_F$		Screw size of connecting screws
$M_{AF}$	[Nm]	Required tightening torque of connecting screws
$n_{max}$	[min <sup>-1</sup> ]	Allowed rotation frequency
I	[kgm <sup>2</sup> ]	Moment of inertia
m	[kg]	Mass of the complete coupling
ph	[bar]	Hydraulic pressure for opt. Clamping tool

Pos.	Designation
1	Flange
2	Pressure ring
3	Clampingscrews
4	Seal
5	Plug
6	Plug
7	O-Ring
8	Connectingscrews
9	Nut

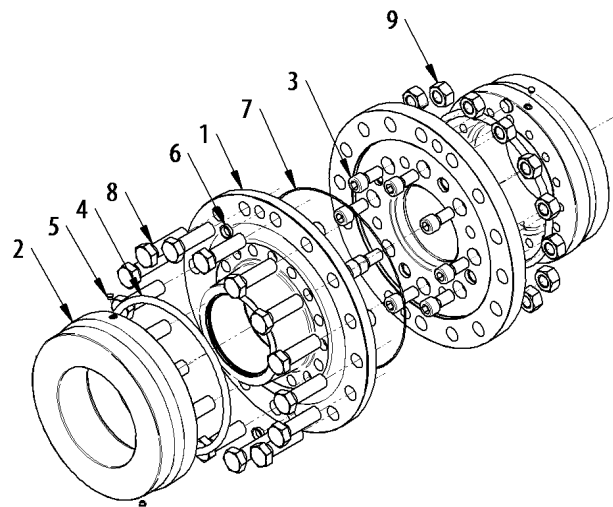

Size FKE (mm)	Shaft d <sub>W</sub> (mm)	Moment		Bend stat.		Bend dyn.		Pressure Ring			Details Coupling							Flange Screws			Further Details			Clampingtool	
		M <sub>max</sub> (Nm)	MBS (Nm)	MBS (Nm)	M <sub>dyn</sub> (Nm)	D <sub>s</sub> (mm)	Z (Stk.)	S	M <sub>t</sub> (Nm)	A (mm)	D (mm)	Dz (mm)	L (mm)	l (mm)	g <sub>min</sub> (mm)	g <sub>max</sub> (mm)	b (mm)	z (mm)	Z (Stk.)	S <sub>t</sub>	M <sub>st</sub> (Nm)	n <sub>max</sub> (min <sup>-1</sup> )	j <sup>st</sup> (kgm <sup>-2</sup> )	m <sup>st</sup> (kg)	ph (bar)
<b>50</b>	40	1030	412	309	118	6	M8x2,5	22	170	200	125	111	35	1	27	29	4	6	M12x45	85	3237	0,047	11,5	-	
	50	2100	840	630	134	8	M8x3,0	21	190	220	145	123	37	1	33	34	4	6	M16x55	210	2851	0,085	16	-	
<b>60</b>	50	1900	760	570	158	8	M10x3,0	40	210	240	170	147	46	1	37	34	4	6	M16x55	210	2418	0,14	22,5	-	
	60	3200	1280	690	200	8	M12x4,0	75	265	305	215	174	56	2	42	42	5	6	M20x70	420	1910	0,44	44,5	-	
<b>75</b>	65	4800	1920	1440	214	9	M12x4,0	80	286	340	230	188	60	2	46	44	5	5	M24x80	720	1785	0,67	56	-	
	75	7300	2920	2190	276	8	M16x5,0	200	356	400	300	220	71	2	52	54	5	8	M24x90	720	1384	1,7	105	-	
<b>90</b>	80	9800	3920	2490	284	8	M16x5,0	200	356	400	300	220	71	2	52	54	5	8	M24x90	720	1345	1,75	105	-	
	90	13100	5240	3930	320	8	M20x5,0	400	420	475	350	264	84	2	66	64	6	10	M30x100	1450	1194	4,2	175	235	
<b>100</b>	90	13500	5400	4050	345	8	M24x5,0	530	440	510	370	296	100	2	66	64	6	14	M30x100	1450	1107	5,6	205	230	
	100	17900	7160	5370	390	8	M24x5,0	690	475	540	405	312	108	2	66	64	6	16	M30x100	1450	979	8	260	240	
<b>120</b>	100	24700	9880	7410	415	8	M27x6,0	800	500	560	430	350	123	2	70	72	8	16	M30x110	1450	920	10,7	315	245	
	120	38700	15480	11610	445	8	M27x6,0	860	530	590	460	372	135	2	70	72	8	18	M30x110	1450	858	14	370	240	
<b>130</b>	110	28700	11480	8610	467	9	M27x6,0	870	555	615	485	394	145	2	74	72	8	20	M30x110	1550	818	17,5	420	235	
	130	42600	17040	12780	548	9	M33x6,5	1720	640	710	570	434	153	2	92	86	8	24	M30x130	1550	697	36,5	660	240	
<b>150</b>	130	57500	23000	17250	560	9	M33x6,5	1720	660	720	590	444	158	2	92	86	8	24	M30x130	1550	682	39	660	225	
	150	80000	32000	24000	615	9	M36x8,0	2300	735	805	660	482	170	2	102	92	8	28	M30x130	1550	621	63,5	890	240	
<b>165</b>	135	64000	25600	19200	615	9	M36x8,0	2300	735	805	660	482	170	2	102	92	8	28	M30x130	1550	621	63,5	890	240	
	165	103000	41200	30900	690	8	M24x5,0	530	440	510	370	296	100	2	66	64	6	14	M30x100	1450	1107	5,6	205	230	
<b>180</b>	150	93000	37200	27900	390	8	M24x5,0	690	475	540	405	312	108	2	66	64	6	16	M30x100	1450	979	8	260	240	
	180	144000	57600	43200	415	8	M27x6,0	800	500	560	430	350	123	2	70	72	8	16	M30x110	1450	920	10,7	315	245	
<b>200</b>	170	129000	51600	38700	415	8	M27x6,0	800	500	560	430	350	123	2	70	72	8	16	M30x110	1450	920	10,7	315	245	
	200	190000	76000	57000	445	8	M27x6,0	860	530	590	460	372	135	2	70	72	8	18	M30x110	1450	858	14	370	240	
<b>220</b>	180	156000	62400	46800	445	8	M27x6,0	860	530	590	460	372	135	2	70	72	8	18	M30x110	1450	858	14	370	240	
	220	250000	100000	75000	467	9	M27x6,0	870	555	615	485	394	145	2	74	72	8	20	M30x110	1550	818	17,5	420	235	
<b>240</b>	200	205000	82000	61500	467	9	M27x6,0	870	555	615	485	394	145	2	74	72	8	20	M30x110	1550	818	17,5	420	235	
	240	315000	126000	90000	548	9	M33x6,5	1720	640	710	570	434	153	2	92	86	8	24	M30x130	1550	697	36,5	660	240	
<b>260</b>	220	297000	118800	71400	548	9	M33x6,5	1720	640	710	570	434	153	2	92	86	8	24	M30x130	1550	697	36,5	660	240	
	260	435000	174000	130500	560	9	M33x6,5	1720	660	720	590	444	158	2	92	86	8	24	M30x130	1550	682	39	660	225	
<b>290</b>	240	336000	134400	100800	560	9	M33x6,5	1720	660	720	590	444	158	2	92	86	8	24	M30x130	1550	682	39	660	225	
	290	519000	207600	155700	615	9	M36x8,0	2300	735	805	660	482	170	2	102	92	8	28	M30x130	1550	621	63,5	890	240	
<b>310</b>	260	462000	184800	138600	615	9	M36x8,0	2300	735	805	660	482	170	2	102	92	8	28	M30x130	1550	621	63,5	890	240	
	310	697000	278800	178000	615	9	M36x8,0	2300	735	805	660	482	170	2	102	92	8	28	M30x130	1550	621	63,5	890	240	

Size FKE (mm)	Shaft d <sub>W</sub> (mm)	Moment M <sub>T</sub> (Nm)	Bend stat. M <sub>BS</sub> (Nm)	Bend dyn. M <sub>BD</sub> (Nm)	Pressure ring			Details Coupling							Flange Screws			Further Details			Clamping tool				
					D <sub>s</sub> (mm)	Z	S	A	D	Dz	L	l	g <sub>min</sub> (mm)	g <sub>max</sub> (mm)	b	z	Z <sub>L</sub> (Stk)	S <sub>L</sub>	M <sub>LF</sub> (Nm)	n <sub>max</sub> (min <sup>-1</sup> )		l*	m*	ph (bar)	
<b>340</b>	290	600000	240000	180000	644	10	M36x80	2300	770	835	690	530	187	2	112	98	10	30	M30x130	1550	593	80,5	1020	230	
	340	862000	344800	220000	700	12	M36x80	2300	845	920	770	554	194	2	122	118	10	35	M30x130	1550	546	118	1250	235	
<b>380</b>	310	757000	302800	227100	768	12	M42x110	2700	940	1030	850	616	210	4	144	124	12	32	M36x180	2500	497	206	1730	240	
	380	1198000	479200	255000	828	14	M42x110	3000	1000	1100	900	694	245	4	154	128	14	36	M36x180	2500	461	302	2250	240	
<b>410</b>	350	980000	392000	294000	900	16	M42x110	3050	1080	1180	980	742	267	4	154	130	14	40	M36x180	2500	424	439	2860	235	
	410	1430000	572000	340000	955	16	M42x110	3100	1110	1210	1020	742	267	4	154	130	14	42	M36x180	2500	409	496	3000	235	
<b>440</b>	380	1410000	564000	423000																					
	440	1960000	784000	460000																					
<b>470</b>	410	1680000	672000	504000																					
	470	2300000	920000	690000																					
<b>500</b>	440	1860000	744000	558000																					
	500	2500000	1000000	750000																					

\* related to nominal size

Order key ( product labeling )

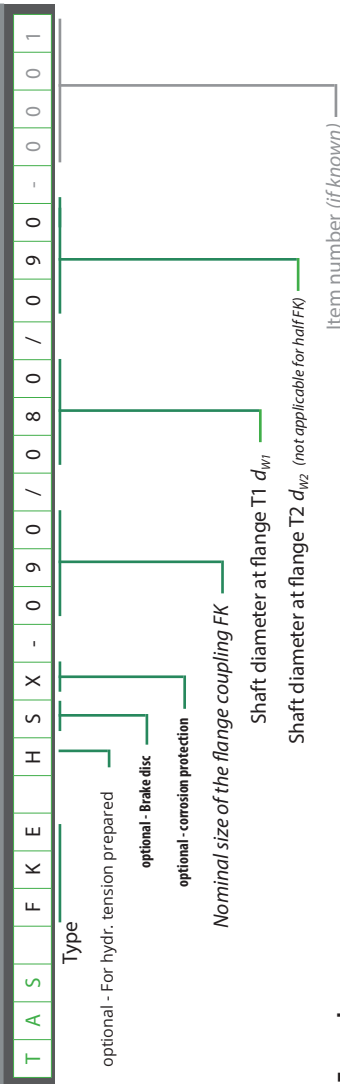

Examples:

- TAS FKE-090/085/095 Flange coupling in nominal size FKE = 090 / d<sub>W1</sub> = Ø85 / d<sub>W2</sub> = Ø95
- TAS FKE H-090/085/095 Flange coupling with preparation for hydraulic clamping tool in nominal size FKE = 090 / d<sub>W1</sub> = Ø85 / d<sub>W2</sub> = Ø95
- TAS FKE S-090/085/095 Flange coupling with brake disc in nominal size FKE = 090 / d<sub>W1</sub> = Ø85 / d<sub>W2</sub> = Ø95
- TAS FKE X-090/085/095 Flange coupling with extended corrosive protection in nominal size FKE = 090 / d<sub>W1</sub> = Ø85 / d<sub>W2</sub> = Ø95
- TAS FKE HX-090/085/095 Flange coupling with preparation for hydraulic clamping tool with extended corrosive protection in nominal size FKE = 090 / d<sub>W1</sub> = Ø85 / d<sub>W2</sub> = Ø95

\*Additional options can be combined as required



# Hydraulic clamping tool TAS HY for FKE H

## Short description:

The clamping tool is placed onto the front of one coupling half and is used to clamp the pressure ring of the coupling.

The tool is removed After locking the coupling half, and can be used for further couplings of the same nominal size.

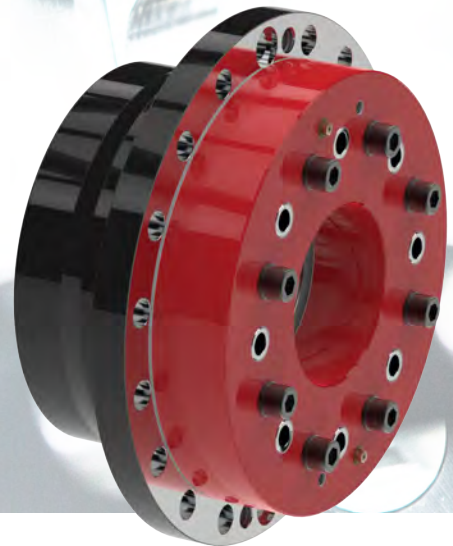

## Used symbols

Typ HY		Nominal size
z	[pcs.]	Number of screws at the hydraulic tool
D	[mm]	Outer diameter of the hydraulic tool
d	[mm]	Inner diameter of the hydraulic tool
b	[mm]	Width of the hydraulic tool without screws
m	[kg]	Weight
v	[l]	Oil volume

Oil type: HLP-46

Pos.	Designation
1	Tool HY
2	Main Screws
3	Flange half FKE H

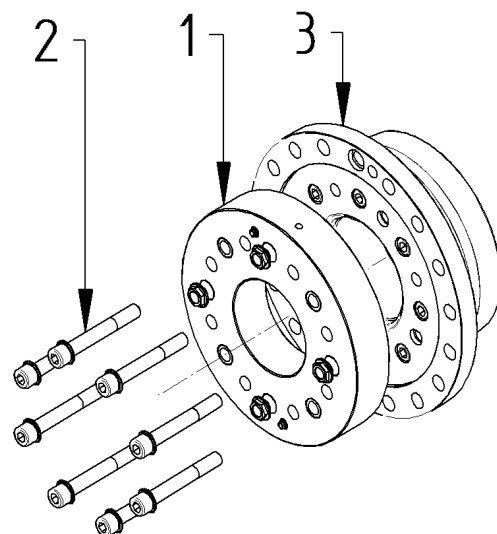
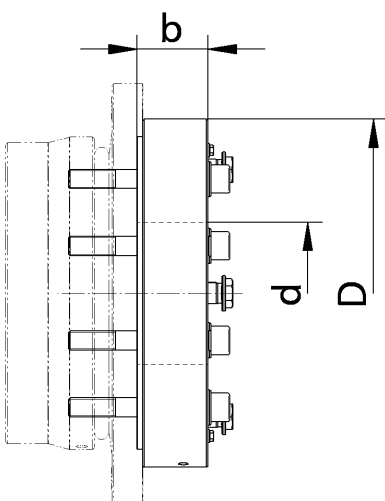

# Hydraulic clamping tool TAS HY for FKE H

Typ HY Designation	Nominal Size FKE	Screws		Compatible Pressure Rings				Dimensions			Mass	Oilvolume
		Size	Z (Pcs.)	Pressurering Size	Pressure ph (bar)	Pressurering	Pressure ph (bar)	D (Pcs.)	d (mm)	b (mm)	(kg)	v (l)
HY 150-71-185	<b>150</b>	M20x180	8	150-71-185	235	130-51-175	160	370	120	95	70	0,7
HY 165-71-195	<b>165</b>	M24x180	8	165-71-195	230	150-51-195	175	400	130	95	80	0,9
HY 180-71-220	<b>180</b>	M24x180	8	180-71-220	240	165-51-220	160	440	145	95	100	1,5
HY 200-71-240	<b>200</b>	M27x200	8	200-71-240	245	180-51-240	220	470	180	100	110	1,5
HY 220-71-260	<b>220</b>	M27x200	8	220-71-260	240	200-51-260	230	490	200	100	120	1,6
HY 240-71-280	<b>240</b>	M27x200	9	240-71-280	235	220-51-280	240	520	210	100	140	1,9
HY 260-71-320	<b>260</b>	M33x220	9	260-71-320	240	240-51-320	165	630	200	110	240	3,8
HY 290-71-340	<b>290</b>	M33x220	9	290-71-340	225	260-51-340	190	650	220	110	260	4,1
HY 310-71-360	<b>310</b>	M36x240	9	310-71-360	240	290-51-360	180	695	235	130	340	4,7
HY 340-71-390	<b>340</b>	M36x240	10	340-71-390	230	310-51-390	195	740	275	130	380	6,5
HY 380-71-420	<b>380</b>	M36x240	12	380-71-420	235	340-51-420	175	805	290	130	450	7,6
HY 410-71-460	<b>410</b>	M42x260	12	410-71-460	240	380-51-460	190	875	325	130	530	9,8
HY 440-71-500	<b>440</b>	M42x260	14	440-71-500	240	410-51-500	180	955	345	140	680	12,6
HY 470-71-560	<b>470</b>	M42x260	16	470-71-560	235	440-51-560	185	1050	390	140	820	15,0
HY 500-71-590	<b>500</b>	M42x260	16	500-71-590	235	470-51-590	215	1075	425	140	840	15,4

One additional seal kit is included as well as clamping screws and if necessary adapters for pressure rings of the light series 51.

# Connecting Flange AFS

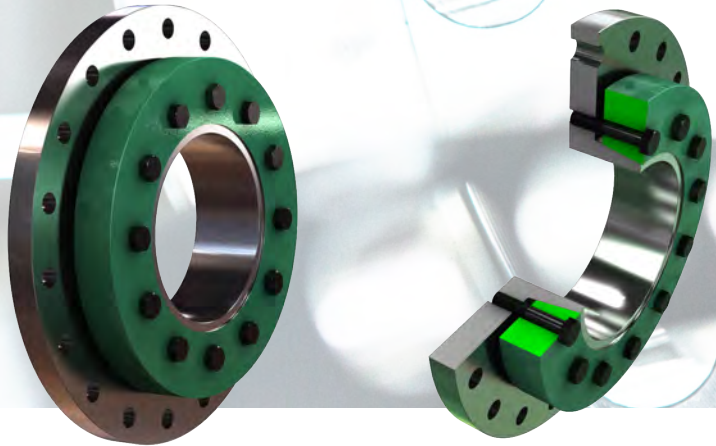
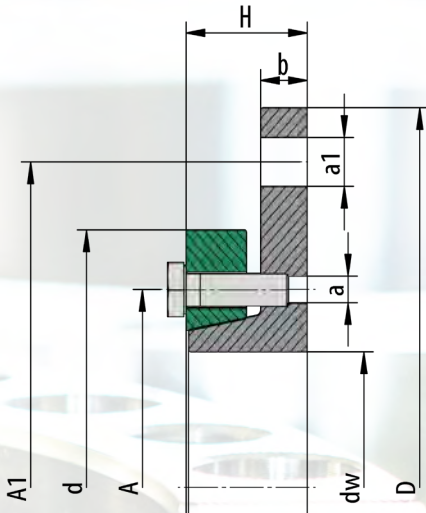

## Used Symbols

$d_w$	[mm]	Shaft diameter
D	[mm]	Outer diameter of the connecting flange
$M_{t \max}$	[Nm]	max transmittable torque
H	[mm]	Width of the connecting flange
d	[mm]	Outer diameter disc D
A	[mm]	Pitch circle diameter disc D
$A_1$	[mm]	Pitch circle diameter flange
b	[mm]	Width of the flange
Z		Number of screws disc D
S		Size
$M_A$	[Nm]	Required tightening torque
S/a		Number/ Size bores of the flange

## Design of the connecting flange

Alternative versions with centering, tapped holes and additional sizes on request.

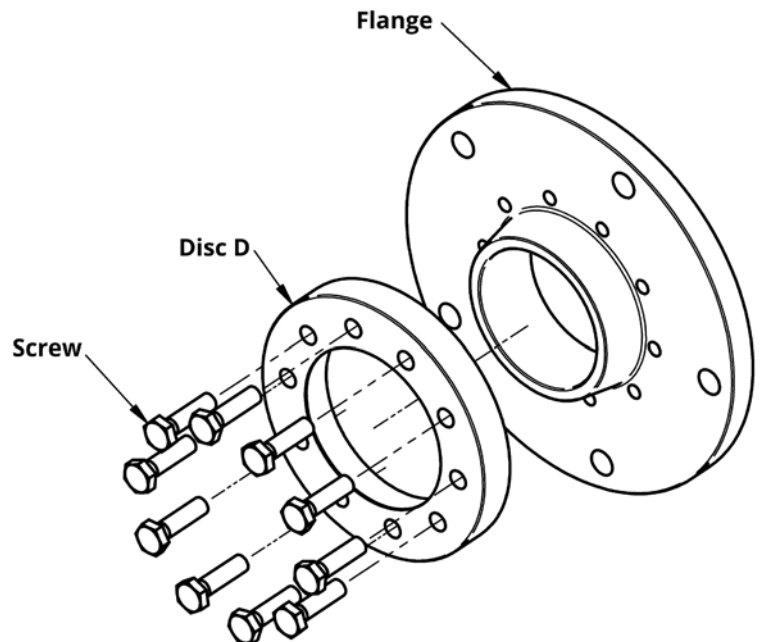

Example: AFS-200/470



# Connecting Flange AFS

$d_w$ mm	$D$ mm	$M_{t,max}$ Nm	$H$ mm	$d$ mm	$A$ mm	$Z$ Pcs	$S$	$M_A$ Nm	$A_1$ mm	$S/a$	$M_A$ Nm	$b$ mm	Weight kg
<b>30</b>	<b>105</b>	310	23	70	54	6	M6 x 020	12	90	4/6,6	12	8	1,00
<b>35</b>	<b>110</b>	450	23	75	59	7	M6 x 020	12	95	5/6,6	12	8	1,1
<b>40</b>	<b>130</b>	645	26	85	64	8	M6 x 022	12	110	4/9	30	10	1,3
<b>45</b>	<b>135</b>	850	26	90	68	9	M6 x 022	12	115	4/9	30	10	1,4
<b>50</b>	<b>140</b>	1100	27	95	73	10	M6 x 025	12	120	5/9	30	10	1,7
<b>55</b>	<b>150</b>	1375	27	105	78	11	M6 x 025	12	130	5/9	30	10	1,9
<b>60</b>	<b>155</b>	1725	28	110	84	12	M6 x 025	12	135	6/9	30	10	2,0
<b>65</b>	<b>170</b>	1940	30	125	95	7	M8 x 030	30	150	7/9	30	10	2,6
<b>70</b>	<b>180</b>	2500	30	135	100	8	M8 x 030	30	160	8/9	30	10	3,1
<b>75</b>	<b>195</b>	3000	34	140	105	9	M8 x 030	30	170	6/11	59	12	3,6
<b>80</b>	<b>200</b>	3650	34	145	110	10	M8 x 030	30	175	7/11	59	12	4,1
<b>85</b>	<b>210</b>	4150	37	155	118	11	M8 x 035	30	185	7/11	59	12	4,8
<b>90</b>	<b>215</b>	4950	37	160	123	12	M8 x 035	30	190	8/11	59	12	5,4
<b>100</b>	<b>235</b>	7350	40	180	138	10	M10 x 040	59	210	10/11	59	12	5,7

# AF Series 12

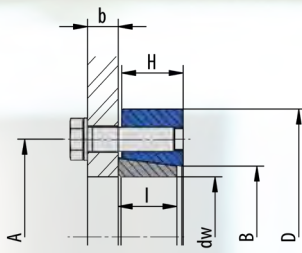

Model A

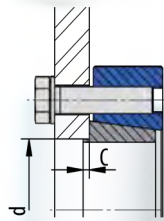

Model AB

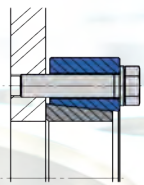

Model C

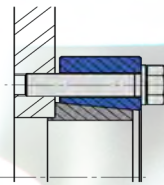

Model BC

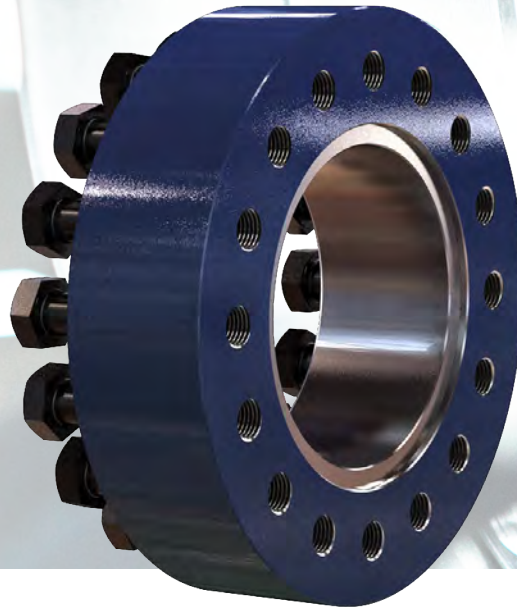

## Used symbols

Typ		Nominal size
$d_w$	[mm]	Shaft diameter
$M_{t \max}$	[Nm]	Max transmittable torque
D	[mm]	Outer diameter
I	[mm]	Length of the bush
H	[mm]	Width of the external clamping element
A	[mm]	Pitch circle diameter
C	[mm]	Length of the centering
d	[mm]	Diameter of the centering
B	[mm]	Attachment size
<b>Screws</b>		
Z		Number of screws
S		Size of screws
$M_A$	[Nm]	Required tightening torque

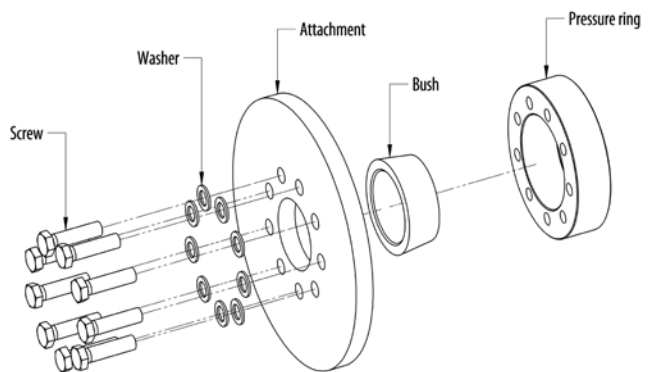

Example: **AF-60-12-60 A**

## Design of the external clamping element

$d < \text{Ø}125$ -pressure rings lightly oiled  
 $d \geq \text{Ø}125$ -pressure rings painted

### Applies to all types:

$b > 1,4 \times \text{Screw diameter}$

From M10 with washers

## Details of the fit

Shaft:

up to  $d_w$  150mm H7 / h6  
 from  $d_w$  155mm H7 / g6

Centring:

up to d 150mm H7 / h6  
 from d 155mm H7 / g6

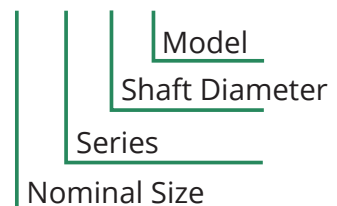

# AF Series 12

Type	$d_w$ mm	$Mt_{max}$ Nm	D mm	I mm	H mm	A mm	C mm	d mm	B mm	Z Pcs.	S	Class	Ma Nm	Weight kg
AF-10	11	20	39	9	10	25	1,5	12	13	3	M6x18	10.9	12	0,1
	10	20												
	9	20												
AF-12	13	50	44	12	13	28	1,5	14	16	3	M6x20	10.9	12	0,1
	12	50												
	11	50												
AF-15	16	130	52	14	15	36	2	18	21	3	M8x25	10.9	29	0,2
	15	130												
	14	130												
AF-20	20	200	60	16	17	42	2	22	25	3	M8x30	10.9	29	0,3
	18	200												
	16	200												
AF-25	25	340	70	18	19	48	2	27	31	5	M8x30	10.9	29	0,4
	22	340												
	20	340												
AF-30	30	550	76	20	21	56	2	32	35	6	M8x35	10.9	29	0,6
	28	550												
	25	550												
AF-40	40	1060	96	24	25	70	3	43	47	6	M10x35	10.9	58	1,2
	35	1060												
	30	1060												
AF-50	50	2200	112	29	30	84	3	53	58	7	M12x45	10.9	100	2
	45	1800												
	40	1000												
AF-60	60	3230	120	32	34	94	3	63	66	9	M12x50	10.9	100	2,3
	55	3230												
	50	2300												
AF-70	70	5800	148	38	40	112	4	74	79	8	M16x60	10.9	240	4,2
	65	5800												
	60	4500												
AF-80	80	8640	170	42	44	130	4	84	94	9	M16x65	10.9	240	6,1
	75	8640												
	70	6900												
AF-90	90	12000	185	48	50	144	4	94	104	12	M16x70	10.9	240	8
	85	12000												
	80	10700												
AF-100	100	15800	197	52	54	156	4	104	113	14	M16x75	10.9	240	9,5
	95	15800												
	90	15800												



# AF Series 22

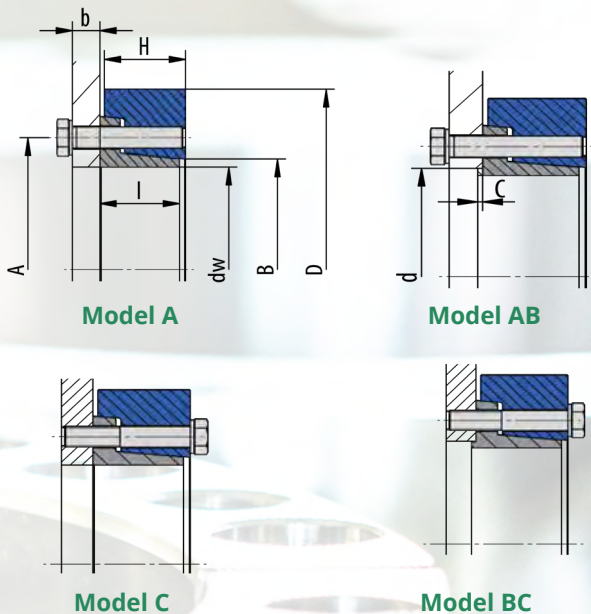

## Used symbols

Typ		Nominal size
$d_w$	[mm]	Shaft diameter
$M_{t \max}$	[Nm]	Max transmittable torque
D	[mm]	Outer diameter
I	[mm]	Length of the bush
H	[mm]	Width of the external clamping element
A	[mm]	Pitch circle diameter
C	[mm]	Length of the centering
d	[mm]	Diameter of the centering
B	[mm]	Attachment size
<b>Screws</b>		
Z		Number of screws
S		Size of screws
$M_A$	[Nm]	Required tightening torque

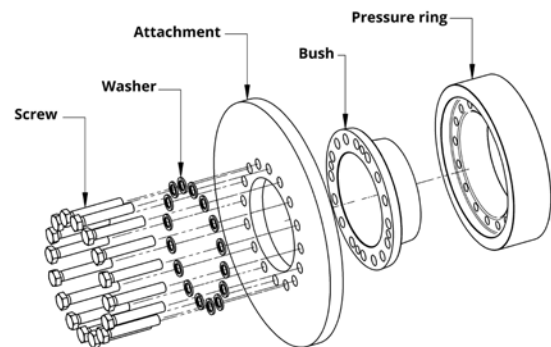

Example: **AF-60-22-60 A**

## Design of the external clamping element

$d < \varnothing 125$ -pressure rings lightly oiled  
 $d \geq \varnothing 125$ -pressure rings painted

**Applies to all types:**  
 $b > 1,4 \times$  Screw diameter

From M10 with washers

## Details of the fit

Shaft:  
 up to  $d_w$  150mm H7 / h6  
 from  $d_w$  155mm H7 / g6

Centring:  
 up to d 150mm H7 / h6  
 from d 155mm H7 / g6

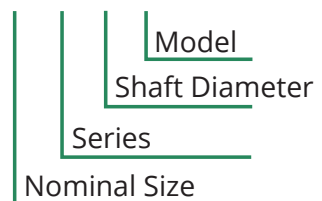

# AF Series 22

Typ	$d_w$ mm	$Mt_{max}$ Nm	D mm	I mm	H mm	A mm	C mm	d mm	B mm	Z Pcs.	S	Class	Ma Nm	Weight kg
AF-12	12	50	35	10	16	24	1,5	14	13	3	M6x20	10.9	12	0,1
	11	50												
AF-14	14	70	38	10	16	26	1,5	16	15	3	M6x20	10.9	12	0,1
	13	70												
AF-16	16	80	41	13,5	20	28	2	18	17	3	M6x25	10.9	12	0,1
	15	80												
AF-18	18	130	44	13,5	20	30	2	20	19	4	M6x25	10.9	12	0,1
	17	130												
AF-20	20	140	47	13,5	20	32	2	22	21	4	M6x25	10.9	12	0,2
	19	140												
AF-25	25	200	50	17	17	36	2	27	26	5	M6x30	10.9	12	0,2
	24	200												
	22	200												
AF-30	30	300	60	18	19	44	3	32	32	6	M6x30	10.9	12	0,3
	28	300												
	26	300												
AF-35	36	500	72	20	21	52	3	38	38	5	M8x35	10.9	29	0,5
	35	500												
	32	450												
AF-40	44	750	80	22	23	61	3	46	47	6	M8x35	10.9	29	0,7
	40	750												
	38	720												
AF-50	50	1300	90	24	25	68	3	53	53	8	M8x40	10.9	29	0,9
	45	1300												
	42	1000												
AF-55	55	1600	100	26	27	72	3	58	58	8	M8x40	10.9	29	1,2
	52	1600												
	45	1600												
AF-60	62	2000	110	26	27	80	3	63	66	9	M8x40	10.9	29	1,4
	60	2000												
	50	2000												
AF-70	70	2100	115	26	27	86	4	74	72	9	M8x40	10.9	29	1,5
	65	2100												
	60	2100												
AF-80	80	4000	141	28	29	100	4	84	82	10	M10x45	10.9	58	2,5
	75	4000												
	70	4000												
AF-90	90	5700	155	34	35	114	4	94	94	12	M10x50	10.9	58	3,6
	85	5700												
	80	5700												

# AF Series 22

Type	$d_w$ mm	$Mt_{max}$ Nm	D mm	I mm	H mm	A mm	C mm	d mm	B mm	Z Pcs.	S	Class	Ma Nm	Weight kg
AF-100	100	8400	170	39	40	124	4	104	104	12	M12x60	10.9	100	4,6
	95	8400												
	90	8400												
AF-110	110	9200	185	45	46	136	5	116	114	12	M12x70	10.9	100	6,2
	105	9200												
	100	9200												
AF-125	125	21000	215	48	50	160	5	126	134	12	M16x75	10.9	240	8,8
	120	21000												
	115	21000												
AF-140	140	26000	230	52	54	176	5	146	146	14	M16x80	10.9	240	11
	135	26000												
	130	26000												
AF-155	160	31000	263	54	55	192	5	166	162	15	M16x80	10.9	240	15
	155	31000												
	150	31000												
AF-170	170	36000	290	61	62	204	5	176	175	16	M16x90	10.9	240	21
	165	36000												
	160	36000												
AF-180	180	43000	300	61	62	218	5	186	185	18	M16x90	10.9	240	22
	175	43000												
	170	43000												
AF-190	190	60000	320	77	78	232	5	196	195	15	M20x110	10.9	470	31
	185	60000												
	180	60000												
AF-200	200	67000	340	75	78	246	5	206	209	16	M20x110	10.9	470	35
	195	67000												
	190	67000												
AF-220	220	93000	370	95	96	278	5	226	230	14	M24x130	10.9	820	53
	210	93000												
	200	93000												
AF-240	240	117000	405	98	100	296	5	246	248	16	M24x140	10.9	820	64
	230	117000												
	220	117000												
AF-260	260	126000	430	106	106	318	5	266	266	16	M24x150	10.9	820	80
	250	126000												
	240	126000												
AF-280	280	151000	460	118	118	340	5	286	288	18	M24x160	10.9	820	95
	270	151000												
	260	151000												
AF-300	300	178000	485	125	126	360	5	306	309	20	M24x170	10.9	820	110
	290	178000												
	280	178000												
AF-320	320	248000	520	125	126	380	5	330	328	20	M27x170	10.9	1210	134
	300	248000												
	280	248000												



# AF Series 22

Type	$d_w$ mm	$Mt_{max}$ Nm	D mm	I mm	H mm	A mm	C mm	d mm	B mm	Z Pcs.	S	Class	Ma Nm	Weight kg
AF-340	340	275000	570	134	136	402	5	350	351	21	M27x180	10.9	1210	180
	320	275000												
	300	275000												
AF-360	360	290000	590	142	144	424	8	370	367	21	M27x180	10.9	1210	200
	340	290000												
	320	290000												
AF-390	390	363000	630	146	148	458	8	400	398	20	M30x190	10.9	1640	222
	370	363000												
	350	363000												
AF-420	420	407000	650	166	168	490	8	430	424	21	M30x210	10.9	1640	263
	400	407000												
	380	407000												
AF-440	440	426000	670	174	176	512	8	450	448	21	M30x220	10.9	1640	309
	420	426000												
	400	426000												



# AF Series 23

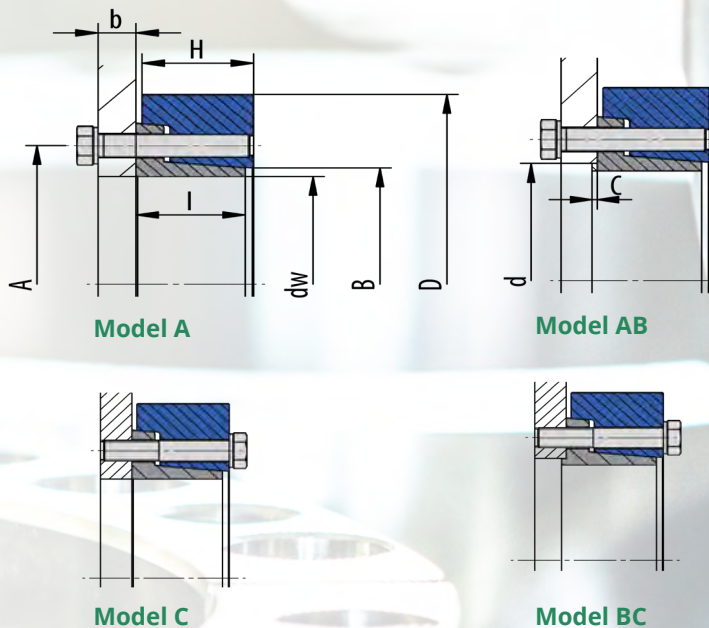

## Used symbols

Typ		Nominal size
$d_w$	[mm]	Shaft diameter
$M_{t \max}$	[Nm]	Max transmittable torque
D	[mm]	Outer diameter
I	[mm]	Length of the bush
H	[mm]	Width of the external clamping element
A	[mm]	Pitch circle diameter
C	[mm]	Length of the centering
d	[mm]	Diameter of the centering
B	[mm]	Attachment size
<b>Screws</b>		
Z		Number of screws
S		Size of screws
$M_A$	[Nm]	Required tightening torque

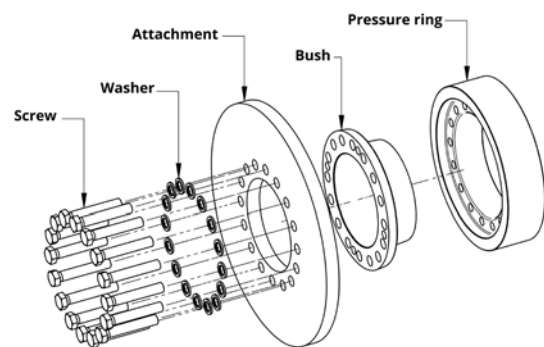

Example: **AF-60-23-60 A**

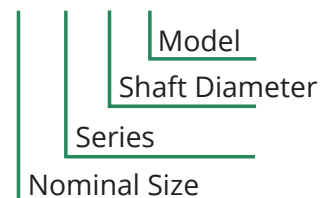

## Design of the external clamping element

$d < \varnothing 125$ -pressure rings lightly oiled  
 $d \geq \varnothing 125$ -pressure rings painted

## Applies to all types:

$b > 1,4 \times$  Screw diameter

From M10 with washers

## Details of the fit

Shaft:

up to  $d_w$  150mm H7 / h6  
 from  $d_w$  155mm H7 / g6

Centring:

up to d 150mm H7 / h6  
 from d 155mm H7 / g6

# AF Series 23

Type	$d_w$ mm	$Mt_{max}$ Nm	D mm	I mm	H mm	A mm	C mm	d mm	B mm	Z Pcs.	S	Class	Ma Nm	Weight kg
AF-50	50	3300	115	29	30	84	3	53	58	7	M12x45	10.9	100	2
	45	2200												
	40	1400												
AF-60	60	4700	120	32	34	94	3	63	66	9	M12x50	10.9	100	2,2
	55	3500												
	50	2300												
AF-70	70	9400	148	38	40	112	4	74	79	8	M16x60	10.9	240	3,9
	65	7600												
	60	5800												
AF-80	80	12000	167	43	46	130	4	84	94	9	M16x65	10.9	240	5,4
	75	10000												
	70	8000												
AF-90	90	18000	185	48	50	144	4	94	104	12	M16x70	10.9	240	7,4
	85	15000												
	80	12000												
AF-100	100	23000	197	52	54	156	4	104	114	14	M16x75	10.9	240	8,7
	95	19000												
	90	16000												
AF-110	110	27000	215	56	58	166	5	116	124	10	M20x90	10.9	470	11
	105	26000												
	100	22000												
AF-120	120	43000	230	62	65	186	5	126	134	14	M20x90	10.9	470	13,6
	115	38000												
	110	33000												
AF-140	140	56000	290	75	76	216	5	146	160	16	M20x100	10.9	470	29
	130	50000												
	120	39000												
AF-160	160	77000	320	82	83	234	5	166	180	14	M24x110	10.9	820	36,1
	150	77000												
	140	64000												
AF-180	180	104000	340	91	94	276	5	186	205	16	M24x130	10.9	820	45,3
	170	101000												
	160	85000												
AF-200	200	144000	370	95	96	290	5	206	226	16	M27x140	10.9	1210	53,7
	190	133000												
	180	114000												
AF-220	220	178000	405	96	96	320	5	226	246	18	M27x140	10.9	1210	64,3
	210	178000												
	200	159000												
AF-240	240	211000	430	109	110	340	5	246	267	20	M27x150	10.9	1210	81
	230	211000												
	220	211000												
AF-260	260	232000	460	118	118	356	5	286	289	21	M27x160	10.9	1210	109,4
	250	234000												
	240	234000												



# AF Series 23

Type	$d_w$ mm	$Mt_{max}$ Nm	D mm	I mm	H mm	A mm	C mm	d mm	B mm	Z Pcs.	S	Class	Ma Nm	Weight kg
AF-280	280	234000	485	124	125	360	5	306	304	21	M27x180	10.9	1210	116
	270	234000												
	260	234000												
AF-300	300	247000	520	128	126	380	5	330	315	21	M27x180	10.9	1210	141
	290	247000												
	280	247000												
AF-320	320	299000	550	134	136	402	5	350	336	24	M27x180	10.9	1210	161
	310	299000												
	300	299000												
AF-340	340	315000	570	140	143	424	8	370	368	24	M27x180	10.9	1210	177
	330	315000												
	320	315000												
AF-360	360	410000	610	144	147	454	8	400	383	24	M30x190	10.9	1640	210
	350	410000												
	340	410000												
AF-390	390	439000	630	164	167	486	8	430	428	24	M30x200	10.9	1640	250
	380	439000												
	360	439000												
AF-420	420	457000	670	172	175	506	10	450	440	24	M30x220	10.9	1640	292
	410	457000												
	390	457000												
AF-440	440	562000	700	172	175	534	10	470	468	28	M30x220	10.9	1640	318
	420	562000												
	400	562000												



**Modern  
mechanical  
processing  
in perfection**

**TAS**  
**SCHÄFER**



**TAS**  
**SCHÄFER**



# Shaft Couplings

Rigid shaft Coupling

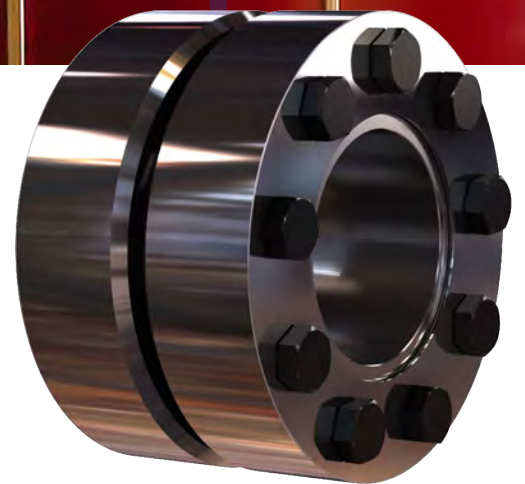



# Description of function

## Rigid Shaft Coupling

The main function of the rigid shaft coupling is the safe and backlash-free connection of two shafts by means of friction. For example between a drive shaft and driven shaft and mainly to transmit torque. Shaft couplings consist of a connecting sleeve and two external clamping systems. They are not separable like flange coupling. The external clamping systems generate a backlash-free connection by pressing the connecting sleeve onto the shaft ends.

The external clamping system does not transmit any torque or moments between the shaft ends, they just provide the necessary clamping forces. Those external clamping systems are not part of the flow of forces, but the connecting sleeve is.

The couplings have to be installed by moving them onto the shaft ends followed by tightening of the external clamping systems via bolting. To achieve proper operation and a sufficiently high coefficient of friction, the contact surfaces at the shaft extensions must be free of grease, dry and clean.

Our rigid shaft couplings are supplied ready for installation. The functional surfaces of the external clamping systems, threads and head rests of the screws are provided with lubricant at the factory.

### Product data

A detailed installation manual is available on the Internet.

#### Data Sheets

Contact us if a data sheet for an individual product is required.

- For CAD data of couplings, contact us directly, please.

**Rolf Gertner**  
rolf.gertner@tas-schaefer.de

or

**Mike Kemper**  
mike.kemper@tas-schaefer.de

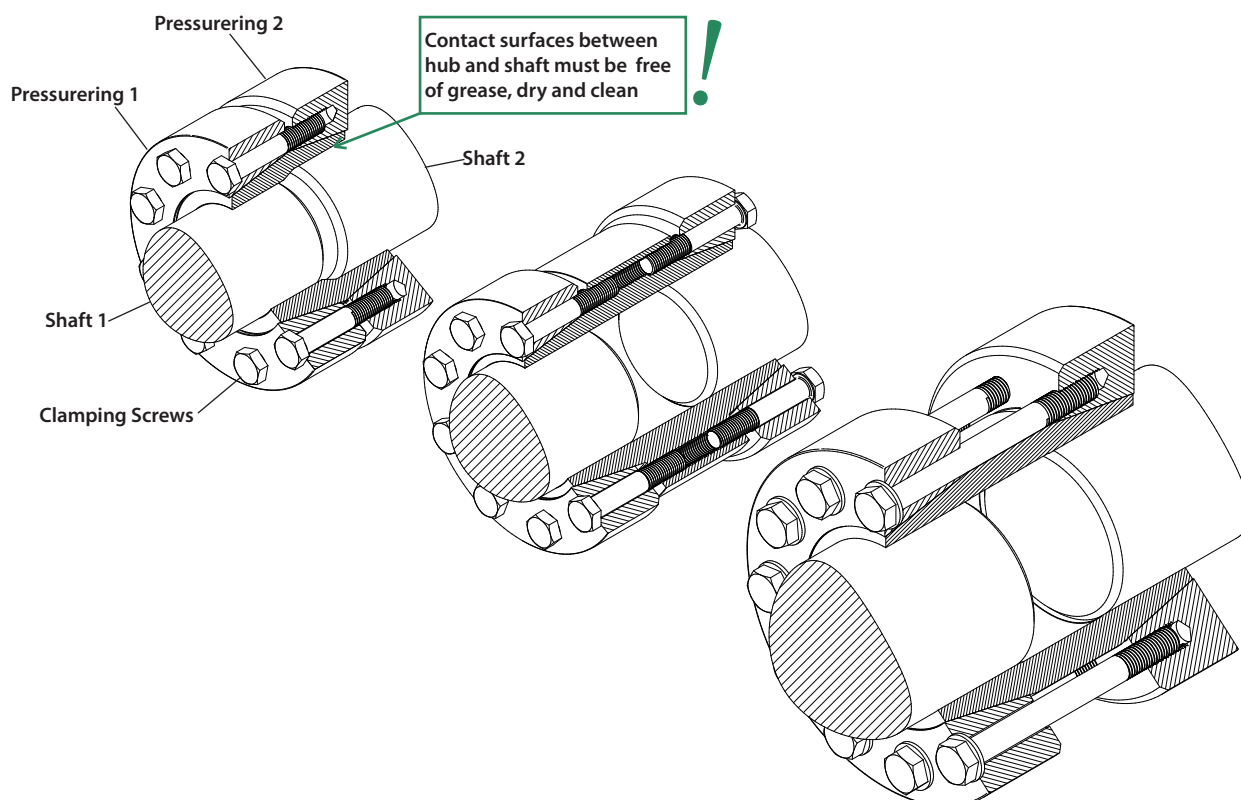

# Basics-Design

## Advantages and differences to other systems

### Clamping length for pressure rings

The insertion depth of the shaft at the junction IK (between shaft and sleeve), should be chosen to be somewhat wider to minimize the stress concentration at this point. An excessively wide connection increases the tendency to fretting corrosion, because the pressure decreases outward. The pressure is distributed approximately at an angle between 15° - 20° through the hub. This is largely dependent on the hub wall thickness and stiffness of the shaft. A good approximation can be made from the following equation:

### Clamping length for pressure rings

The insertion depth of the shaft at the junction IK (between shaft and sleeve), should be chosen to be somewhat wider to minimize the stress concentration at this point. An excessively wide connection increases the tendency to fretting corrosion, because the pressure decreases outward. The pressure is distributed approximately at an angle between 15° - 20° through the hub. This is largely dependent on the hub wall thickness and stiffness of the shaft. A good approximation can be made from the following equation:

Clamping length of the insertion depth:

$$l_K = 0,316(d - d_w) + l$$

The cylindrical surfaces should be located symmetrically under the shrink disc or pressure ring! With a slightly different clamping length the transmissible torque M will not change, because a smaller contact surface results in a higher pressure - also a larger contact surface causes lower pressure.

### Pursue the same diameter - but an adaptation to different diameters is also possible

Basically the target should be to connect shaft ends of the same size. With larger deviations the sleeves can be adapted for the different diameters. This is done by using different pressure rings or shrink discs or bore diameter.

### Tightening torque of the clamping screws

When using different pressure rings and shaft diameters, the tightening torque and therefore the clamping forces are adjustable. For example, this is also possible with soft shaft materials and reduces, if required, the stresses in the components.

$$M(New) = \frac{M_{Agew}}{M_A} M \quad \text{also}$$

$$p_N(New) = \frac{M_{Agew}}{M_A} p_N$$

The tightening torques can not be reduced arbitrary, therefore apply the following limits:

$$M_{Agew} \geq \begin{pmatrix} \text{Class 8.8 : } 0,85 M_A \\ \text{Class 10.9 : } 0,70 M_A \\ \text{Class 12.9 : } 0,60 M_A \end{pmatrix} \leq M_A$$

### Positioning

The cylindrical connection, as well as the used clearance, allows an easy and precise positioning of the sleeves on the shaft ends. During the clamping process there is no more shift.

### No hydraulic necessary

A hydraulic expansion of the hubs is not necessary for mounting.

### No heating necessary

There is no need for expansion of the sleeves by heating. To increase the clearance between the shaft and sleeve, a slight warming is possible.

### Shafts with keyways

The couplings can be used on shafts with keyways. As far as possible, the keyways should be closed.

### Tolerances and surfaces

The values found in the product data, are based on surface quality and tolerances, according to the table below. These values are given as recommendations.

Higher surface roughness reduces the transmissible torque and promote unwanted settling.

Larger clearance also reduces the transmissible torque and increases stresses in the connecting sleeve.

**If you need different shaft tolerances, please let us know. The holes in the sleeves can then be adjusted accordingly!**

Recommended tolerances and surfaces roughness				
>	≤	FS <sub>max</sub> mm	Clearance Hub/Shaft	Rz µm
30	50	0,032	H6/h6	10
50	80	0,049	H7/h6	10
80	120	0,057	H7/h6	16
120	150	0,065	H7/h6	16
150	180	0,079	H7/g6	16
180	250	0,090	H7/g6	16
250	315	0,101	H7/g6	16
315	400	0,111	H7/g6	16
400	500	0,123	H7/g6	25
500	630	0,136	H7/g6	25

# Basics-Calculation

The calculation of the values, given in the catalogue, are based on the following assumptions and simplifications:

## Transmissible torque

A shrink connection is capable of transmitting torque, bending moment and axial force. Substituted, the transmissible torque  $M_{max}$  is specified in the product data. If such loads occur simultaneously then they must be added vectorially to the resultant moment  $M_{res}$ . The formula below applies to the resulting moment:

$$M_{res} \leq M_{max}$$

At different load cases, they must be individually checked against  $M_{max}$ !

$M_{res}$  is determined for combined loads as follows:

$$M_{res} = \sqrt{M_T^2 + 2M_B^2 + (F_{AX} \frac{dW}{2})^2}$$

with  $M_B \leq 0,4 M_{max}$  as the limit\* for the static bending moment

\*In several, the maximum bending moment corresponds to the maximum transmittable torque. The limitation to  $0,4 M_{max}$  is due to the change of the surface pressure at the edges of the connection. (This information applies to the shrink connection of the coupling only!)

## This results in the following relationships:

### Torque only:

The maximum torque is equivalent to  $M_{max}$ .

### Bending moment only:

The maximum static bending moment corresponds to  $0,4 M_{max}$ .

### Axial force only:

The maximum axial force is  $M_{max} \frac{2}{d_w}$

## Static and dynamic load

For some applications, a static review of the coupling is sufficient. The clamping forces of the shrink connection are static. Also steady torques and/or axial forces can be considered as static loads. Rotating bending, has to be considered as dynamic load and the coupling must be examined for that. Therefore, it is also essential to specify the occurring load cases.

## Shaft calculation

The sleeve will be deformed due to the applied clamping force. In addition to the clearance between shaft and sleeve, shaft stiffness and surface finish should be considered. For solid shafts the stiffness can be ignored, but with hollow shafts (see „Bore in the shaft (hollow shaft)“) there is higher deformation and thus higher stresses in the components. This must be considered in addition to other loads.

## Notch effect

Generally there is a notch effect on the components, caused by the radial pressure of the pressure ring. This depends mainly on the applied pressure. The notch effect is generally higher on the sleeve than on the shaft, because the pressure ring is directly pressed onto the sleeve, while the stresses are distributed through the sleeve before reaching the shaft. The notch factors range from 2,5 to 3,5 for the sleeve and between 1,5 and 2 for the shaft. This can be mitigated by suitable design features, such as relief notches.

## Bore in the shaft (hollow shaft)

A large bore  $d_B$  in the shaft or the use of a hollow shaft, reduces the stiffness of this component against radial pressure. This leads to a decrease in pressure  $p_w$ , a reduced transmissible torque  $M$ , a contraction  $\Delta d_B$  within the shaft and an increase of stresses in these components. Basically, a bore should not be greater than  $0,3 d_w$ .



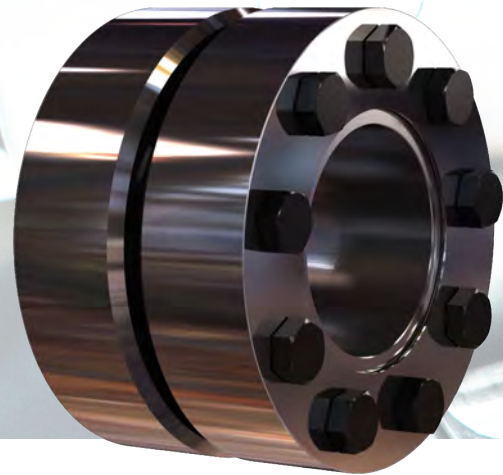
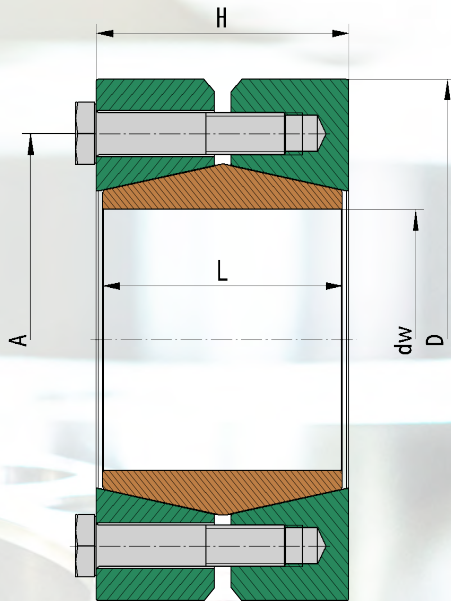

### Used symbols

$d_w$ [mm]	Shaft diameter	
$M_{max}$ [Nm]	max. transmittable torque	$F_{ax} = 0$
$F_{ax}$ [kN]	max. transmittable axial force	$M_t = 0$
$D$ [mm]	Outer diameter of coupling	
$L$ [mm]	Length of sleeve	
$H$ [mm]	Width of shaft coupling	
$A$ [mm]	Pitch circle diameter of bolting	
$M_A$	Required tightening torque of clamping screws	
$Z$	Number of screws	
$S$	Size of screws	
$p_w$ [N/mm <sup>2</sup> ]	Average contact pressure on the shaft	

### Design of the disc

$d < 070$	Discs lightly oiled without washers
$d \geq 070$	Discs painted with washers

Dimensions H & e in unlocked position

Pos.	Designation
1	Sleeve
2	Pressure ring G
3	Pressure ring DG
4	Screw

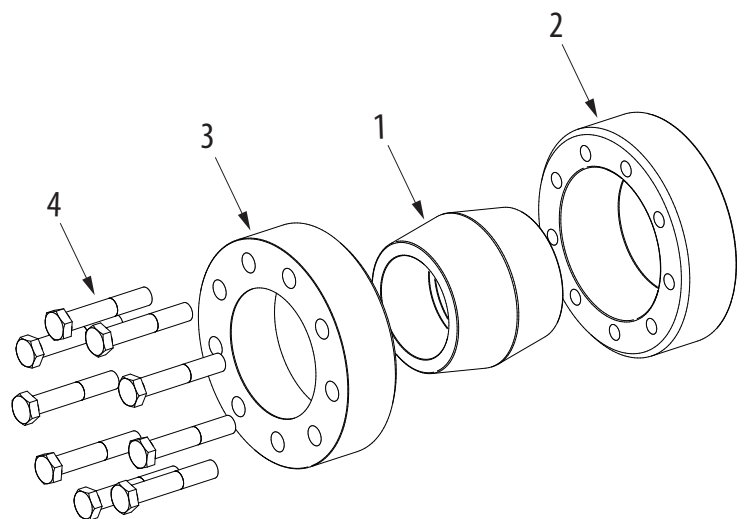
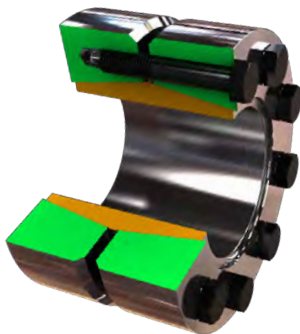

Ordering example: TAS W-Typ/d1/ d2 (e.g: TAS W070/065/070 ... further sizes on request)

Type	$d_w$	$M_{max}$	$F_{ax}$	$D$	$L$	$H$	$A$	$M_A$	$Z$	$S$	DIN	Class	$p_w$	Weight
mm	mm	Nm	kN	mm	mm	mm	mm	mm	Pcs				N/mm <sup>2</sup>	Kg
W011	10	30	6	47	25	27	30	6	6	M5 x 20	933	10.9	150	0,4
W011	11	36	7	47	25	27	30	6	6	M5 x 20	933	10.9	189	0,4
W011	12	60	10	47	25	27	30	6	6	M5 x 20	933	10.9	222	0,4
W015	13	70	11	55	30	33	37	6	7	M5 x 25	933	10.9	83	0,5
W015	15	150	20	55	30	33	37	6	7	M5 x 25	933	10.9	126	0,5
W015	17	180	21	55	30	33	37	6	7	M5 x 25	933	10.9	160	0,5
W020	18	200	22	60	34	37	42	12	8	M6 x 30	931	10.9	213	0,7
W020	20	270	27	60	34	37	42	12	8	M6 x 30	931	10.9	241	0,7
W020	22	350	31	60	34	37	42	12	8	M6 x 30	931	10.9	266	0,7
W025	23	370	32	66	38	41	48	12	8	M6 x 30	931	10.9	178	0,8
W025	25	470	37	66	38	41	48	12	8	M6 x 30	931	10.9	197	0,8
W025	27	600	44	66	38	41	48	12	8	M6 x 30	931	10.9	214	0,8
W030	28	540	38	76	42	45	54	12	10	M6 x 35	931	10.9	215	1,3
W030	30	670	44	76	42	45	54	12	10	M6 x 35	931	10.9	217	1,3
W030	32	750	46	76	42	45	54	12	10	M6 x 35	931	10.9	231	1,3
W035	33	750	45	80	46	49	62	12	12	M6 x 35	931	10.9	168	1,5
W035	35	900	51	80	46	49	62	12	12	M6 x 35	931	10.9	180	1,5
W035	37	1050	56	80	46	49	62	12	12	M6 x 35	931	10.9	190	1,5
W040	38	1250	65	98	50	54	71	30	8	M8 x 40	931	10.9	175	2,5
W040	40	1550	77	98	50	54	71	30	8	M8 x 40	931	10.9	184	2,5
W040	43	1850	86	98	50	54	71	30	8	M8 x 40	931	10.9	196	2,5
W050	44	2200	100	115	60	64	86	59	8	M10 x 45	931	10.9	189	4
W050	50	3300	132	115	60	64	86	59	8	M10 x 45	931	10.9	200	4
W050	54	3800	140	115	60	64	86	59	8	M10 x 45	931	10.9	212	4
W060	55	4050	147	125	70	74	98	59	10	M10 x 50	931	10.9	177	5,3
W060	60	5100	170	125	70	74	98	59	10	M10 x 50	931	10.9	190	5,3
W060	64	6100	190	125	70	74	98	59	10	M10 x 50	931	10.9	198	5,3
W070	65	6500	200	148	80	85	112	59	12	M10 x 60	931	10.9	172	8,4
W070	70	8200	234	148	80	85	112	59	12	M10 x 60	931	10.9	181	8,4
W070	74	9000	243	148	80	85	112	59	12	M10 x 60	931	10.9	188	8,4
W080	75	10500	280	170	94	99	130	100	12	M12 x 70	931	10.9	73	13,1
W080	80	12300	307	170	94	99	130	100	12	M12 x 70	931	10.9	186	13,1
W080	84	14000	333	170	94	99	130	100	12	M12 x 70	931	10.9	192	13,1
W090	85	14200	334	185	104	109	145	250	7	M16 x 80	931	10.9	166	17
W090	90	16400	364	185	104	109	145	250	7	M16 x 80	931	10.9	173	17
W090	94	18000	383	185	104	109	145	250	7	M16 x 80	931	10.9	177	17
W100	80	19100	402	200	114	119	158	250	9	M16 x 90	931	10.9	200	21
W100	100	23100	462	200	114	119	158	250	9	M16 x 90	931	10.9	189	21
W100	104	26000	500	200	114	119	158	250	9	M16 x 90	931	10.9	193	21
W110	105	28500	542	217	124	129	170	250	12	M16 x 90	931	10.9	214	27
W110	110	32000	581	217	124	129	170	250	12	M16 x 90	931	10.9	218	27
W110	114	35000	614	217	124	129	170	250	12	M16 x 90	931	10.9	221	27
W120	115	38500	669	235	134	139	184	250	13	M16 x 90	931	10.9	199	33
W120	120	43500	725	235	134	139	184	250	13	M16 x 90	931	10.9	200	33
W120	124	46000	742	235	134	139	184	250	13	M16 x 90	931	10.9	204	33

# W

Type	$d_w$	$M_{max}$	$F_{ax}$	$D$	$L$	$H$	$A$	$M_A$	$Z$	$S$	DIN	Class	$pw$	Weight
mm	mm	Nm	kN	mm	mm	mm	mm	mm	Pcs.				N/mm <sup>2</sup>	Kg
<b>W130</b>	125	47500	760	267	150	155	206	490	10	M20 x 110	931	10.9	195	45
<b>W130</b>	130	55000	846	267	150	155	206	490	10	M20 x 110	931	10.9	198	45
<b>W130</b>	134	58000	865	267	150	155	206	490	10	M20 x 110	931	10.9	200	45
<b>W140</b>	135	62000	918	280	160	165	218	490	11	M20 x 110	931	10.9	192	55
<b>W140</b>	140	67000	957	280	160	165	218	490	11	M20 x 110	931	10.9	195	55
<b>W140</b>	144	71000	986	280	160	165	218	490	11	M20 x 110	931	10.9	197	55
<b>W150</b>	145	73000	1006	302	170	175	230	490	12	M20 x 120	931	10.9	186	70
<b>W150</b>	150	78000	1040	302	170	175	230	490	12	M20 x 120	931	10.9	188	70
<b>W150</b>	154	82000	1065	302	170	175	230	490	12	M20 x 120	931	10.9	190	70
<b>W160</b>	115	82000	1058	315	180	185	242	490	13	M20 x 120	931	10.9	178	80
<b>W160</b>	120	88000	1100	315	180	185	242	490	13	M20 x 120	931	10.9	182	80
<b>W160</b>	125	97000	1175	315	180	185	242	490	13	M20 x 120	931	10.9	184	80
<b>W180</b>	166	108000	1301	345	200	205	265	490	16	M20 x 130	931	10.9	179	105
<b>W180</b>	180	132000	1465	345	200	205	265	490	16	M20 x 130	931	10.9	181	105
<b>W180</b>	185	140000	1513	345	200	205	265	490	16	M20 x 130	931	10.9	183	105
<b>W200</b>	186	153000	1645	375	225	230	295	490	20	M20 x 150	931	10.9	174	135
<b>W200</b>	200	184000	1840	375	225	230	295	490	20	M20 x 150	931	10.9	178	135
<b>W200</b>	210	204000	1943	375	225	230	295	490	20	M20 x 150	931	10.9	182	135
<b>W220</b>	211	214000	2028	410	253	258	320	840	18	M24 x 160	931	10.9	191	180
<b>W220</b>	220	240000	2180	410	253	258	320	840	18	M24 x 160	931	10.9	193	180
<b>W220</b>	230	260000	2260	410	253	258	320	840	18	M24 x 160	931	10.9	196	180
<b>W240</b>	231	280000	2424	435	273	278	350	840	20	M24 x 180	931	10.9	182	210
<b>W240</b>	240	305000	2540	435	273	278	350	840	20	M24 x 180	931	10.9	184	210
<b>W240</b>	250	334000	2672	435	273	278	350	840	20	M24 x 180	931	10.9	185	210
<b>W260</b>	251	390000	3108	515	300	305	380	1250	20	M27 x 200	931	10.9	204	345
<b>W260</b>	260	425000	3270	515	300	305	380	1250	20	M27 x 200	931	10.9	206	345
<b>W260</b>	270	465000	3444	515	300	305	380	1250	20	M27 x 200	931	10.9	208	345



**QUALITY ON  
every continent**

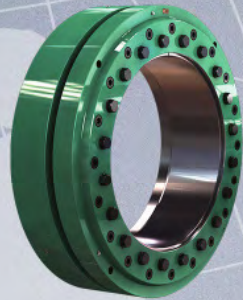

Hydraulic Shrink Disc  
for Gearbox test benches



Hydraulic Shrink Disc  
for Wind power and Industrial applications

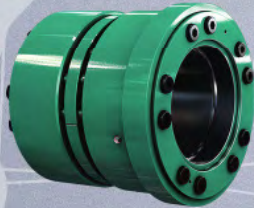

Hydraulic Shaft Coupling  
for shaftings

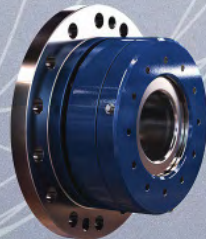

Hydraulic Flange Coupling  
for Conveyor drives

**TAS  
SCHÄFER**



[www.tas-schaefer.de](http://www.tas-schaefer.de)

MAIL: [info@tas-schaefer.de](mailto:info@tas-schaefer.de) | TEL.: +49 (0) 2335 9781-0



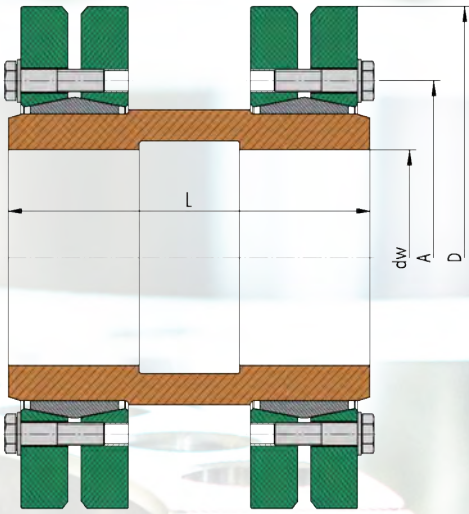

### Used symbols

$d_w$ [mm]	Shaft diameter	
$M_{max}$ [Nm]	max. transmittable torque	$F_{ax} = 0$
$F_{ax}$ [kN]	max. transmittable axial force	$M_t = 0$
$D$ [mm]	Outer diameter of coupling	
$L$ [mm]	Length of sleeve	
$H$ [mm]	Width of shaft coupling	
$A$ [mm]	Pitch circle diameter of bolting	
$M_A$	Required tightening torque of clamping screws	
$Z$	Number of screws	
$S$	Size of screws	
$p_w$ [N/mm <sup>2</sup> ]	Average contact pressure on the shaft	

### Design of the disc

$d < 115$	Discs galvanized without washers
$d \geq 115$	Discs painted with washers

Dimensions H & e in unlocked position

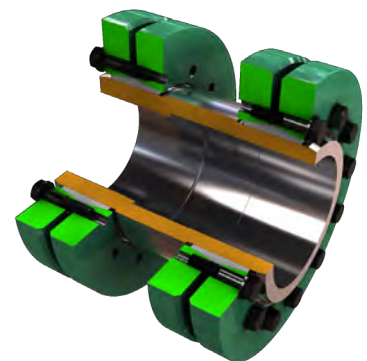

Pos.	Designation
1	Sleeve
2	Shrink Disc
3	Shrink Disc

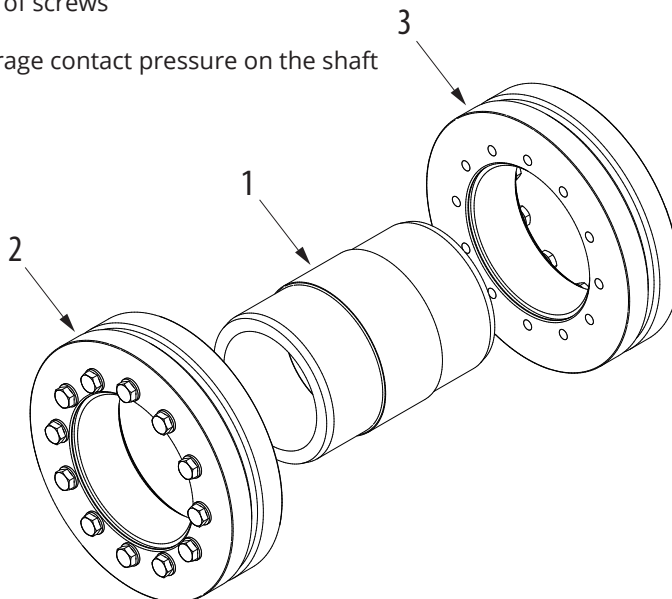

Ordering example: TAS WK-Typ/d/D (e.g: TAS WK 240/150/200 ... further sizes on request)

Type	$d_w$	$M_{max}$	$F_{ax}$	$D$	$L$	$A$	$M_A$	$Z$	$S$	DIN	Class	$p_w$	Weight
mm	mm	Nm	kN	mm	mm	mm	mm	Pcs.				N/mm <sup>2</sup>	Kg
WK024	19	250	26	50	50	36	6	6	M5	933	10.9	235	0,7
WK024	20	300	30	50	50	36	6	6	M5	933	10.9	254	0,7
WK024	21	360	34	50	50	36	6	6	M5	933	10.9	273	0,7
WK030	24	310	26	60	55	44	6	6	M5	933	10.9	159	1
WK030	25	360	29	60	55	44	6	6	M5	933	10.9	171	1
WK030	26	420	32	60	55	44	6	6	M5	933	10.9	183	1
WK036	28	500	36	72	65	52	12	5	M6	933	10.9	169	1,3
WK036	30	640	43	72	65	52	12	5	M6	933	10.9	186	1,3
WK036	31	690	45	72	65	52	12	5	M6	933	10.9	189	1,3
WK044	34	880	52	80	70	61	12	7	M6	933	10.9	178	2
WK044	35	970	55	80	70	61	12	7	M6	933	10.9	185	2
WK044	36	1000	56	80	70	61	12	7	M6	933	10.9	192	2
WK050	38	1000	53	90	80	70	12	8	M6	931	10.9	161	2,5
WK050	40	1200	60	90	80	70	12	8	M6	931	10.9	172	2,5
WK050	42	1500	71	90	80	70	12	8	M6	931	10.9	182	2,5
WK055	42	1200	57	100	85	75	12	8	M6	931	10.9	139	3,5
WK055	45	1500	67	100	85	75	12	8	M6	931	10.9	152	3,5
WK055	48	1800	75	100	85	75	12	8	M6	931	10.9	164	3,5
WK062	48	1900	79	110	90	86	12	10	M6	931	10.9	168	4
WK062	50	2100	84	110	90	86	12	10	M6	931	10.9	174	4
WK062	52	2200	85	110	90	86	12	10	M6	931	10.9	171	4
WK068	50	1700	68	115	100	86	12	10	M6	931	10.9	145	4,5
WK068	55	2200	80	115	100	86	12	10	M6	931	10.9	148	4,5
WK068	60	2900	97	115	100	86	12	10	M6	931	10.9	166	4,5
WK075	55	2800	102	138	120	100	30	7	M8	931	10.9	175	5
WK075	60	3600	120	138	120	100	30	7	M8	931	10.9	192	5
WK075	65	4600	142	138	120	100	30	7	M8	931	10.9	207	5
WK080	60	3200	107	145	130	100	30	7	M8	931	10.9	168	6
WK080	65	4100	126	145	130	100	30	7	M8	931	10.9	182	6
WK080	70	5100	146	145	130	100	30	7	M8	931	10.9	195	6
WK090	65	4900	151	155	140	114	30	10	M8	931	10.9	181	11
WK090	70	6000	171	155	140	114	30	10	M8	931	10.9	192	11
WK090	75	7300	195	155	140	114	30	10	M8	931	10.9	203	11
WK100	70	6000	171	170	160	124	30	12	M8	931	10.9	170	15
WK100	75	7300	195	170	160	124	30	12	M8	931	10.9	180	15
WK100	80	8800	220	170	160	124	30	12	M8	931	10.9	189	15
WK110	75	7400	197	185	180	136	59	9	M10	931	10.9	159	19
WK110	80	8900	223	185	180	136	59	9	M10	931	10.9	168	19
WK110	85	10300	242	185	180	136	59	9	M10	931	10.9	171	19
WK125	85	11100	261	215	200	160	59	12	M10	931	10.9	172	26
WK125	90	13100	291	215	200	160	59	12	M10	931	10.9	180	26
WK125	95	15200	320	215	200	160	59	12	M10	931	10.9	188	26
WK140	95	15500	326	230	210	175	100	10	M12	931	10.9	175	34
WK140	100	17900	358	230	210	175	100	10	M12	931	10.9	182	34
WK140	105	20400	389	230	210	175	100	10	M12	931	10.9	188	34



# WK

Type mm	$d_w$ mm	$M_{max}$ Nm	$F_{ax}$ kN	$D$ mm	$L$ mm	$A$ mm	$M_A$ mm	$Z$ Pcs.	$S$	DIN	Class	$p_w$ N/mm <sup>2</sup>	Weight Kg
WK155	105	21100	402	265	230	192	100	12	M12	931	10.9	179	50
WK155	110	23900	435	265	230	192	100	12	M12	931	10.9	185	50
WK155	115	26900	468	265	230	192	100	12	M12	931	10.9	190	50
WK165	115	34800	605	290	240	210	250	8	M16	931	10.9	219	65
WK165	120	38700	645	290	240	210	250	8	M16	931	10.9	224	65
WK165	125	42300	677	290	240	210	250	8	M16	931	10.9	226	65
WK175	125	38600	618	300	250	220	250	8	M16	931	10.9	206	68
WK175	130	42600	655	300	250	220	250	8	M16	931	10.9	211	68
WK175	135	46900	695	300	250	220	250	8	M16	931	10.9	215	68
WK185	135	53700	796	330	265	236	250	10	M16	931	10.9	194	100
WK185	140	59000	843	330	265	236	250	10	M16	931	10.9	198	100
WK185	145	64400	888	330	265	236	250	10	M16	931	10.9	202	100
WK195	140	67200	960	350	280	246	250	12	M16	931	10.9	226	110
WK195	150	79500	1060	350	280	246	250	12	M16	931	10.9	233	110
WK195	155	84800	1094	350	280	246	250	12	M16	931	10.9	232	110
WK200	150	76700	1023	350	290	246	250	12	M16	931	10.9	224	125
WK200	155	81700	1054	350	290	246	250	12	M16	931	10.9	224	125
WK200	160	88400	1105	350	290	246	250	12	M16	931	10.9	227	125
WK220	160	95800	1198	370	310	270	250	15	M16	931	10.9	199	155
WK220	165	103000	1248	370	310	270	250	15	M16	931	10.9	202	155
WK220	170	111000	1306	370	310	270	250	15	M16	931	10.9	205	155
WK240	170	126000	1482	405	350	295	490	12	M20	931	10.9	221	190
WK240	180	144000	1600	405	350	295	490	12	M20	931	10.9	227	190
WK240	190	163000	1716	405	350	295	490	12	M20	931	10.9	230	190
WK260	190	170000	1789	430	390	321	490	14	M20	931	10.9	214	240
WK260	200	193000	1930	430	390	321	490	14	M20	931	10.9	219	240
WK260	210	217000	2067	430	390	321	490	14	M20	931	10.9	224	240
WK280	210	224000	2133	460	430	346	490	16	M20	931	10.9	209	290
WK280	220	251000	2282	460	430	346	490	16	M20	931	10.9	213	290
WK280	230	280000	2435	460	430	346	490	16	M20	931	10.9	217	290
WK300	230	287000	2496	485	445	364	490	18	M20	931	10.9	208	340
WK300	240	318000	2650	485	445	364	490	18	M20	931	10.9	211	340
WK300	245	334000	2727	485	445	364	490	18	M20	931	10.9	213	340
WK320	240	326000	2717	520	460	386	490	20	M20	931	10.9	217	380
WK320	250	359000	2872	520	460	386	490	20	M20	931	10.9	220	380
WK320	260	391000	3008	520	460	386	490	20	M20	931	10.9	222	380
WK340	250	401000	3208	570	480	408	490	24	M20	931	10.9	224	500
WK340	260	435000	3346	570	480	408	490	24	M20	931	10.9	225	500
WK340	270	476000	3526	570	480	408	490	24	M20	931	10.9	228	500
WK350	270	456000	3378	580	490	432	490	24	M20	931	10.9	209	530
WK350	280	497000	3550	580	490	432	490	24	M20	931	10.9	212	530
WK350	285	518000	3635	580	490	432	490	24	M20	931	10.9	213	530
WK360	280	478000	3414	590	500	432	490	24	M20	931	10.9	203	550
WK360	290	519000	3579	590	500	432	490	24	M20	931	10.9	206	550
WK360	295	541000	3668	590	500	432	490	24	M20	931	10.9	207	550

Type	$d_w$	$M_{max}$	$F_{ax}$	$D$	$L$	$A$	$M_A$	$Z$	$S$	DIN	Class	$p_w$	Weight
mm	mm	Nm	kN	mm	mm	mm	mm	Pcs.				N/mm <sup>2</sup>	Kg
<b>WK380</b>	290	587000	4048	645	530	458	840	20	M24	931	10.9	226	660
<b>WK380</b>	300	635000	4233	645	530	458	840	20	M24	931	10.9	229	660
<b>WK380</b>	310	685000	4419	645	530	458	840	20	M24	931	10.9	231	660
<b>WK390</b>	300	646000	4307	660	540	468	840	21	M24	931	10.9	233	720
<b>WK390</b>	310	697000	4497	660	540	468	840	21	M24	931	10.9	235	720
<b>WK390</b>	320	746000	4663	660	540	468	840	21	M24	931	10.9	236	720
<b>WK420</b>	330	831000	5036	690	580	504	840	24	M24	931	10.9	217	860
<b>WK420</b>	340	891000	5241	690	580	504	840	24	M24	931	10.9	219	860
<b>WK420</b>	350	953000	5446	690	580	504	840	24	M24	931	10.9	221	860
<b>WK440</b>	340	832000	4894	750	600	527	840	24	M24	931	10.9	190	990
<b>WK440</b>	350	891000	5091	750	600	527	840	24	M24	931	10.9	192	990
<b>WK440</b>	360	952000	5289	750	600	527	840	24	M24	931	10.9	194	990
<b>WK460</b>	360	1058000	5878	770	620	547	840	28	M24	931	10.9	216	1100
<b>WK460</b>	370	1127000	6092	770	620	547	840	28	M24	931	10.9	217	1100
<b>WK460</b>	380	1198000	6305	770	620	547	840	28	M24	931	10.9	219	1100
<b>WK480</b>	380	1216000	6400	800	645	570	840	30	M24	931	10.9	209	1300
<b>WK480</b>	390	1290000	6615	800	645	570	840	30	M24	931	10.9	211	1300
<b>WK480</b>	400	1367000	6835	800	645	570	840	30	M24	931	10.9	212	1300
<b>WK500</b>	400	1358000	6790	850	670	590	1250	24	M27	931	10.9	211	1480
<b>WK500</b>	410	1431000	6980	850	670	590	1250	24	M27	931	10.9	211	1480
<b>WK500</b>	420	1513000	7205	850	670	590	1250	24	M27	931	10.9	213	1480

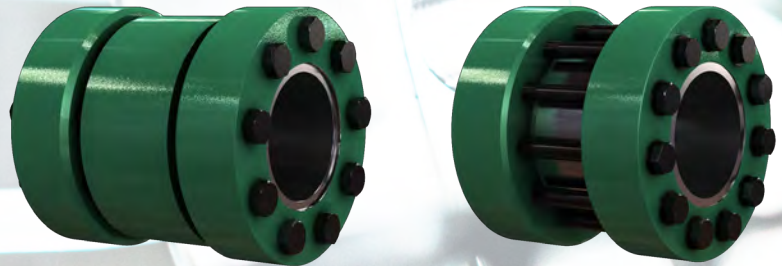
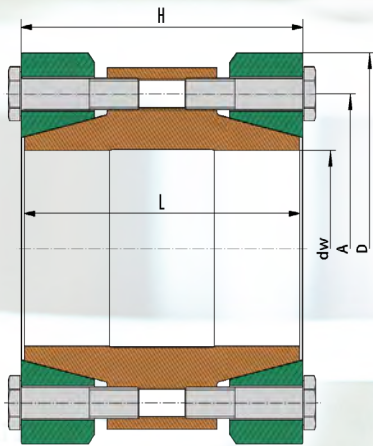

Also available as  
„WLB“ version!

### Used symbols

$d_w$ [mm]	Shaft diameter	
$M_{max}$ [Nm]	max. transmittable torque	$F_{ax} = 0$
$F_{ax}$ [kN]	max. transmittable axial force	$M_t = 0$
$D$ [mm]	Outer diameter of coupling	
$L$ [mm]	Length of sleeve	
$H$ [mm]	Width of shaft coupling	
$A$ [mm]	Pitch circle diameter of bolting	
$M_A$	Required tightening torque of clamping screws	
$Z$	Number of screws	
$S$	Size of screws	
$p_w$ [N/mm <sup>2</sup> ]	Average contact pressure on the shaft	

### Design of the disc

$d < 070$	Discs lightly oiled without washers
$d \geq 070$	Discs painted with washers

Dimensions H & e in unlocked position

Pos.	Designation
1	Sleeve
2	Pressure ring DG
3	Pressure ring DG
4	Screw

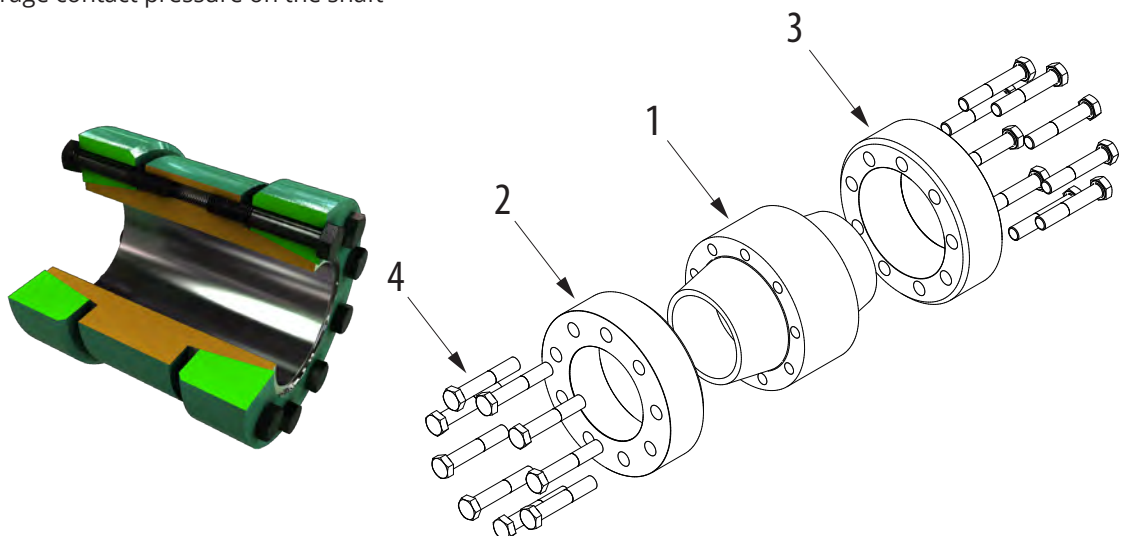

Ordering example: TAS WLA-Typ/d/D (e.g: TAS WLA200/150/200 ... further sizes on request)



Type mm	$d_w$ mm	$M_{max}$ Nm	$F_{ax}$ kN	$D$ mm	$L$ mm	$H$ mm	$A$ mm	$M_A$ mm	$Z$ Pcs (2x)	$S$	DIN	Class	$pw$ N/mm <sup>2</sup>	Weight Kg
WLA015	13	70	11	55	50	53	37	6	7	M5 x 25	933	10.9	83	0,5
WLA015	15	150	20	55	50	53	37	6	7	M5 x 25	933	10.9	126	0,5
WLA015	17	180	21	55	50	53	37	6	7	M5 x 25	933	10.9	160	0,5
WLA020	18	200	22	60	54	57	42	12	8	M6 x 30	931	10.9	213	0,7
WLA020	20	270	27	60	54	57	42	12	8	M6 x 30	931	10.9	241	0,7
WLA020	22	350	31	60	54	57	42	12	8	M6 x 30	931	10.9	266	0,7
WLA025	23	370	32	66	62	65	48	12	8	M6 x 30	931	10.9	178	0,8
WLA025	25	470	37	66	62	65	48	12	8	M6 x 30	931	10.9	197	0,8
WLA025	27	600	44	66	62	65	48	12	8	M6 x 30	931	10.9	214	0,8
WLA030	28	540	38	76	70	73	54	12	10	M6 x 35	931	10.9	164	1,3
WLA030	30	670	44	76	70	73	54	12	10	M6 x 35	931	10.9	165	1,3
WLA030	32	750	46	76	70	73	54	12	10	M6 x 35	931	10.9	179	1,3
WLA035	33	750	45	80	75	79	62	12	12	M6 x 35	931	10.9	168	1,5
WLA035	35	900	51	80	75	79	62	12	12	M6 x 35	931	10.9	180	1,5
WLA035	37	1050	56	80	75	79	62	12	12	M6 x 35	931	10.9	190	1,5
WLA040	38	1250	65	98	80	84	71	30	8	M8 x 40	931	10.9	175	2,5
WLA040	40	1550	77	98	80	84	71	30	8	M8 x 40	931	10.9	184	2,5
WLA040	43	1850	86	98	80	84	71	30	8	M8 x 40	931	10.9	196	2,5
WLA050	44	2200	100	115	90	94	86	59	8	M10 x 45	931	10.9	189	4
WLA050	50	3300	132	115	90	94	86	59	8	M10 x 45	931	10.9	200	4
WLA050	54	3800	140	115	90	94	86	59	8	M10 x 45	931	10.9	212	4
WLA060	55	4050	147	125	120	124	98	59	10	M10 x 50	931	10.9	177	5,3
WLA060	60	5100	170	125	120	124	98	59	10	M10 x 50	931	10.9	190	5,3
WLA060	64	6100	190	125	120	124	98	59	10	M10 x 50	931	10.9	198	5,3
WLA070	65	6500	200	148	140	142	112	59	12	M10 x 60	931	10.9	172	8,4
WLA070	70	8200	234	148	140	142	112	59	12	M10 x 60	931	10.9	181	8,4
WLA070	74	9000	243	148	140	142	112	59	12	M10 x 60	931	10.9	188	8,4
WLA080	75	10500	280	170	170	175	130	100	12	M12 x 70	931	10.9	73	13,1
WLA080	80	12300	307	170	170	175	130	100	12	M12 x 70	931	10.9	186	13,1
WLA080	84	14000	333	170	170	175	130	100	12	M12 x 70	931	10.9	192	13,1
WLA090	85	14200	334	185	200	202	145	250	7	M16 x 80	931	10.9	166	17
WLA090	90	16400	364	185	200	202	145	250	7	M16 x 80	931	10.9	173	17
WLA090	94	18000	383	185	200	202	145	250	7	M16 x 80	931	10.9	177	17
WLA100	95	19100	402	200	210	215	158	250	9	M16 x 90	931	10.9	186	21
WLA100	100	23100	462	200	210	215	158	250	9	M16 x 90	931	10.9	191	21
WLA100	104	26000	500	200	210	215	158	250	9	M16 x 90	931	10.9	195	21
WLA110	105	28500	542	217	220	222	170	250	12	M16 x 90	931	10.9	214	27
WLA110	110	32000	581	217	220	222	170	250	12	M16 x 90	931	10.9	218	27
WLA110	114	35000	614	217	220	222	170	250	12	M16 x 90	931	10.9	221	27
WLA120	115	38500	669	235	230	235	184	250	13	M16 x 90	931	10.9	199	33
WLA120	120	43500	725	235	230	235	184	250	13	M16 x 90	931	10.9	200	33
WLA120	124	46000	742	235	230	235	184	250	13	M16 x 90	931	10.9	204	33
WLA130	125	47500	760	267	240	242	206	490	10	M20 x 110	931	10.9	196	45
WLA130	130	55000	846	267	240	242	206	490	10	M20 x 110	931	10.9	199	45
WLA130	134	58000	865	267	240	242	206	490	10	M20 x 110	931	10.9	202	45

# WLA

Type	$d_w$	$M_{max}$	$F_{ax}$	$D$	$L$	$H$	$A$	$M_A$	$Z$	$S$	DIN	Class	$pw$	Weight
mm	mm	Nm	kN	mm	mm	mm	mm	mm	Pcs (2x)				N/mm <sup>2</sup>	Kg
WLA140	135	62000	918	280	250	252	218	490	11	M20 x 110	931	10.9	194	55
WLA140	140	67000	957	280	250	252	218	490	11	M20 x 110	931	10.9	196	55
WLA140	144	71000	986	280	250	252	218	490	11	M20 x 110	931	10.9	198	55
WLA150	145	73000	1006	302	265	267	230	490	12	M20 x 120	931	10.9	186	70
WLA150	150	78000	1040	302	265	267	230	490	12	M20 x 120	931	10.9	188	70
WLA150	154	82000	1065	302	265	267	230	490	12	M20 x 120	931	10.9	190	70
WLA160	155	82000	1058	315	280	285	242	490	13	M20 x 120	931	10.9	180	80
WLA160	160	88000	1100	315	280	285	242	490	13	M20 x 120	931	10.9	182	80
WLA160	165	97000	1175	315	280	285	242	490	13	M20 x 120	931	10.9	184	80
WLA180	166	108000	1301	345	310	312	265	490	16	M20 x 130	931	10.9	179	105
WLA180	180	132000	1465	345	310	312	265	490	16	M20 x 130	931	10.9	181	105
WLA180	185	140000	1513	345	310	312	265	490	16	M20 x 130	931	10.9	183	105
WLA200	186	153000	1645	375	350	355	295	490	20	M20 x 150	931	10.9	174	135
WLA200	200	184000	1840	375	350	355	295	490	20	M20 x 150	931	10.9	178	135
WLA200	210	204000	1943	375	350	355	295	490	20	M20 x 150	931	10.9	182	135
WLA220	211	214000	2028	410	390	392	320	840	18	M24 x 160	931	10.9	191	180
WLA220	220	240000	2180	410	390	392	320	840	18	M24 x 160	931	10.9	193	180
WLA220	230	260000	2260	410	390	392	320	840	18	M24 x 160	931	10.9	196	180
WLA240	231	280000	2424	435	430	435	350	840	20	M24 x 180	931	10.9	182	210
WLA240	240	305000	2540	435	430	435	350	840	20	M24 x 180	931	10.9	184	210
WLA240	250	334000	2672	435	430	435	350	840	20	M24 x 180	931	10.9	185	210
WLA260	251	390000	3108	515	450	452	380	1250	20	M27 x 200	931	10.9	204	345
WLA260	260	425000	3270	515	450	452	380	1250	20	M27 x 200	931	10.9	206	345
WLA260	270	465000	3444	515	450	452	380	1250	20	M27 x 200	931	10.9	208	345





**TAS**  
**SCHÄFER**



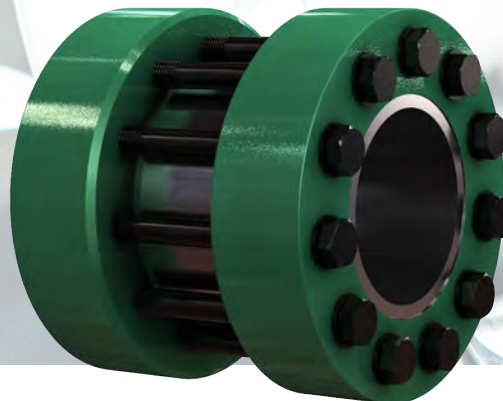
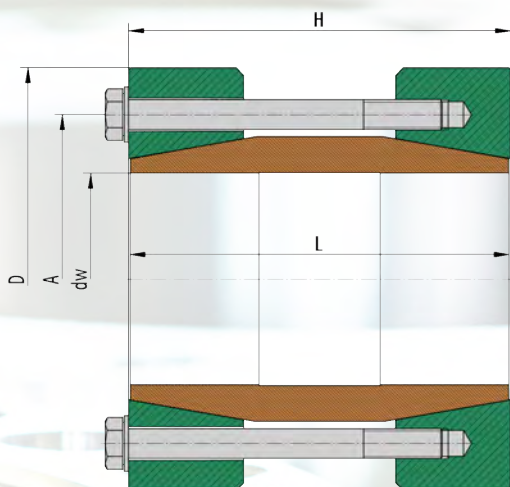

### Used symbols

$d_w$ [mm]	Shaft diameter	
$M_{max}$ [Nm]	max. transmittable torque	$F_{ax} = 0$
$F_{ax}$ [kN]	max. transmittable axial force	$M_t = 0$
$D$ [mm]	Outer diameter of coupling	
$L$ [mm]	Length of sleeve	
$H$ [mm]	Width of shaft coupling	
$A$ [mm]	Pitch circle diameter of bolting	
$M_A$	Required tightening torque of clamping screws	
$Z$	Number of screws	
$S$	Size of screws	
$p_w$ [N/mm <sup>2</sup> ]	Average contact pressure on the shaft	

### Design of the disc

$d < 070$	Discs lightly oiled without washers
$d \geq 070$	Discs painted with washers

Dimensions H & e in unlocked position

Pos.	Designation
1	Sleeve
2	Pressure ring G
3	Pressure ring DG
4	Screw

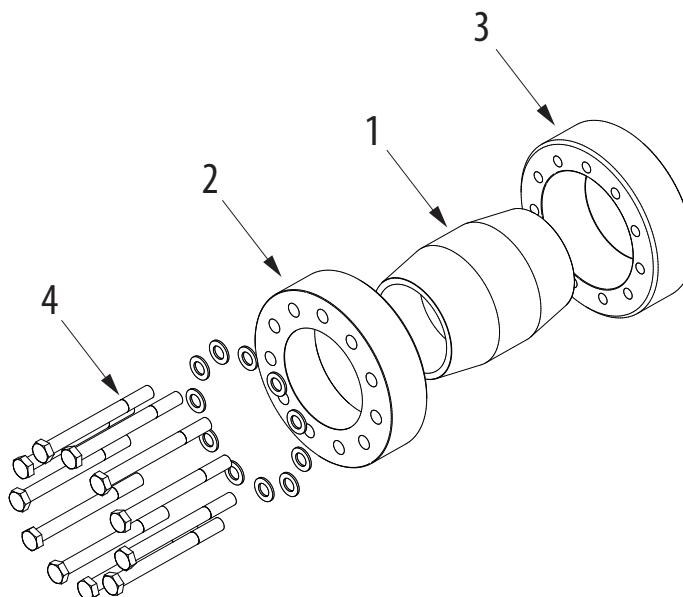
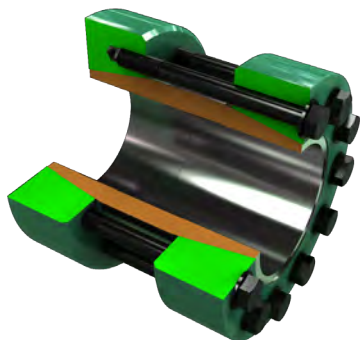

Ordering example: TAS WLB-Typ/d/D (e.g: TAS WLB200/150/200 ... further sizes on request)

Type mm	$d_w$ mm	$M_{max}$ Nm	$F_{ax}$ kN	$D$ mm	$L$ mm	$H$ mm	$A$ mm	$M_A$ mm	$Z$ Pcs.	$S$	DIN	Class	$p_w$ N/mm <sup>2</sup>	Weight Kg
WLB015	13	70	11	55	50	53	37	6	7	M5 x 45	933	10.9	83	0,5
WLB015	15	150	20	55	50	53	37	6	7	M5 x 45	933	10.9	126	0,5
WLB015	17	180	21	55	50	53	37	6	7	M5 x 45	933	10.9	160	0,5
WLB020	18	200	22	60	54	57	42	12	8	M6 x 50	931	10.9	213	0,7
WLB020	20	270	27	60	54	57	42	12	8	M6 x 50	931	10.9	241	0,7
WLB020	22	350	31	60	54	57	42	12	8	M6 x 50	931	10.9	266	0,7
WLB025	23	370	32	66	62	65	48	12	8	M6 x 55	931	10.9	178	0,8
WLB025	25	470	37	66	62	65	48	12	8	M6 x 55	931	10.9	197	0,8
WLB025	27	600	44	66	62	65	48	12	8	M6 x 55	931	10.9	214	0,8
WLB030	28	540	38	76	70	73	54	12	10	M6 x 60	931	10.9	164	1,3
WLB030	30	670	44	76	70	73	54	12	10	M6 x 60	931	10.9	165	1,3
WLB030	32	750	46	76	70	73	54	12	10	M6 x 60	931	10.9	179	1,3
WLB035	33	750	45	80	75	79	62	12	12	M6 x 65	931	10.9	168	1,5
WLB035	35	900	51	80	75	79	62	12	12	M6 x 65	931	10.9	180	1,5
WLB035	37	1050	56	80	75	79	62	12	12	M6 x 65	931	10.9	190	1,5
WLB040	38	1250	65	98	80	84	71	30	8	M8 x 75	931	10.9	175	2,5
WLB040	40	1550	77	98	80	84	71	30	8	M8 x 75	931	10.9	184	2,5
WLB040	43	1850	86	98	80	84	71	30	8	M8 x 75	931	10.9	196	2,5
WLB050	44	2200	100	115	90	94	86	59	8	M10 x 80	931	10.9	189	4
WLB050	50	3300	132	115	90	94	86	59	8	M10 x 80	931	10.9	200	4
WLB050	54	3800	140	115	90	94	86	59	8	M10 x 80	931	10.9	212	4
WLB060	55	4050	147	125	120	124	98	59	10	M10 x 110	931	10.9	177	5,3
WLB060	60	5100	170	125	120	124	98	59	10	M10 x 110	931	10.9	190	5,3
WLB060	64	6100	190	125	120	124	98	59	10	M10 x 110	931	10.9	198	5,3
WLB070	65	6500	200	148	140	142	112	59	12	M10 x 120	931	10.9	172	8,4
WLB070	70	8200	234	148	140	142	112	59	12	M10 x 120	931	10.9	181	8,4
WLB070	74	9000	243	148	140	142	112	59	12	M10 x 120	931	10.9	188	8,4
WLB080	75	10500	280	170	170	175	130	100	12	M12 x 150	931	10.9	73	13,1
WLB080	80	12300	307	170	170	175	130	100	12	M12 x 150	931	10.9	186	13,1
WLB080	84	14000	333	170	170	175	130	100	12	M12 x 150	931	10.9	192	13,1
WLB090	85	14200	334	185	200	202	145	250	7	M16 x 180	931	10.9	166	17
WLB090	90	16400	364	185	200	202	145	250	7	M16 x 180	931	10.9	173	17
WLB090	94	18000	383	185	200	202	145	250	7	M16 x 180	931	10.9	177	17
WLB100	95	19100	402	200	210	215	158	250	9	M16 x 180	931	10.9	186	21
WLB100	100	23100	462	200	210	215	158	250	9	M16 x 180	931	10.9	191	21
WLB100	104	26000	500	200	210	215	158	250	9	M16 x 180	931	10.9	195	21
WLB110	105	28500	542	217	220	222	170	250	12	M16 x 190	931	10.9	214	27
WLB110	110	32000	581	217	220	222	170	250	12	M16 x 190	931	10.9	218	27
WLB110	114	35000	614	217	220	222	170	250	12	M16 x 190	931	10.9	221	27
WLB120	115	38500	669	235	230	235	184	250	13	M16 x 200	931	10.9	199	33
WLB120	120	43500	725	235	230	235	184	250	13	M16 x 200	931	10.9	200	33
WLB120	124	46000	742	235	230	235	184	250	13	M16 x 200	931	10.9	204	33
WLB130	125	47500	760	267	240	242	206	490	10	M20 x 200	931	10.9	196	45
WLB130	130	55000	846	267	240	242	206	490	10	M20 x 200	931	10.9	199	45
WLB130	134	58000	865	267	240	242	206	490	10	M20 x 200	931	10.9	202	45

# WLB

Type	$d_w$	$M_{max}$	$F_{ax}$	$D$	$L$	$H$	$A$	$M_A$	$Z$	$S$	DIN	Class	$pw$	Weight
mm	mm	Nm	kN	mm	mm	mm	mm	mm	Pcs.				N/mm <sup>2</sup>	Kg
WLB140	135	62000	918	280	250	252	218	490	11	M20 x 210	931	10.9	194	55
WLB140	140	67000	957	280	250	252	218	490	11	M20 x 210	931	10.9	196	55
WLB140	144	71000	986	280	250	252	218	490	11	M20 x 210	931	10.9	198	55
WLB150	145	73000	1006	302	265	267	230	490	12	M20 x 220	931	10.9	186	70
WLB150	150	78000	1040	302	265	267	230	490	12	M20 x 220	931	10.9	188	70
WLB150	154	82000	1065	302	265	267	230	490	12	M20 x 220	931	10.9	190	70
WLB160	155	82000	1058	315	280	285	242	490	13	M20 x 230	931	10.9	180	80
WLB160	160	88000	1100	315	280	285	242	490	13	M20 x 230	931	10.9	182	80
WLB160	165	97000	1175	315	280	285	242	490	13	M20 x 230	931	10.9	184	80
WLB180	166	108000	1301	345	310	312	265	490	16	M20 x 250	931	10.9	179	105
WLB180	180	132000	1465	345	310	312	265	490	16	M20 x 250	931	10.9	181	105
WLB180	185	140000	1513	345	310	312	265	490	16	M20 x 250	931	10.9	183	105
WLB200	186	153000	1645	375	350	355	295	490	20	M20 x 280	931	10.9	174	135
WLB200	200	184000	1840	375	350	355	295	490	20	M20 x 280	931	10.9	178	135
WLB200	210	204000	1943	375	350	355	295	490	20	M20 x 280	931	10.9	182	135
WLB220	211	214000	2028	410	390	392	320	840	18	M24 x 320	931	10.9	191	180
WLB220	220	240000	2180	410	390	392	320	840	18	M24 x 320	931	10.9	193	180
WLB220	230	260000	2260	410	390	392	320	840	18	M24 x 320	931	10.9	196	180
WLB240	231	280000	2424	435	430	435	350	840	20	M24 x 340	931	10.9	182	210
WLB240	240	305000	2540	435	430	435	350	840	20	M24 x 340	931	10.9	184	210
WLB240	250	334000	2672	435	430	435	350	840	20	M24 x 340	931	10.9	185	210
WLB260	251	390000	3108	515	450	452	380	1250	20	M27 x 360	931	10.9	204	345
WLB260	260	425000	3270	515	450	452	380	1250	20	M27 x 360	931	10.9	206	345
WLB260	270	465000	3444	515	450	452	380	1250	20	M27 x 360	931	10.9	208	345



**TAS**  
**SCHÄFER**

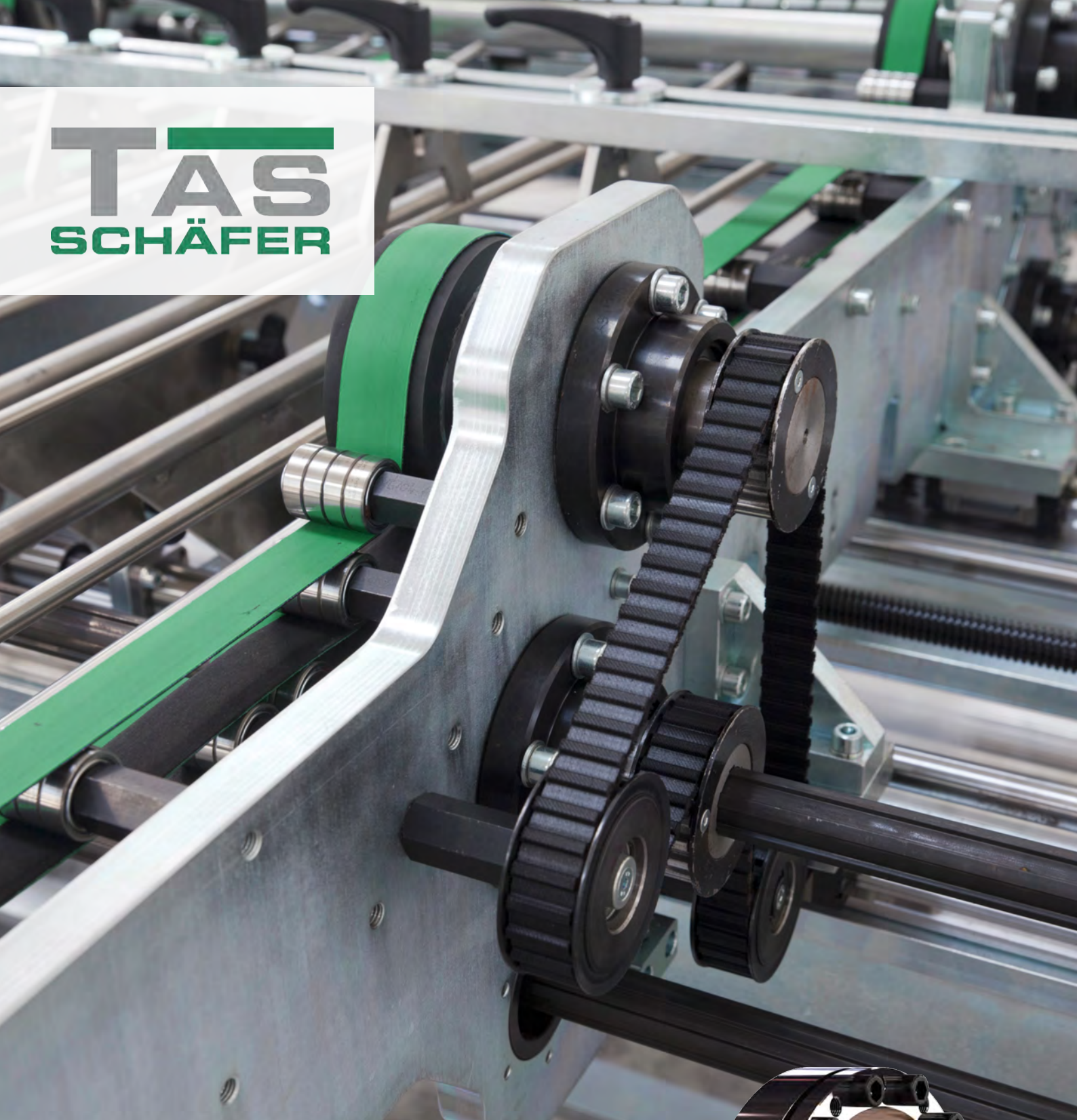

# Internal Locking Devices

Shaft-Hub-Connection

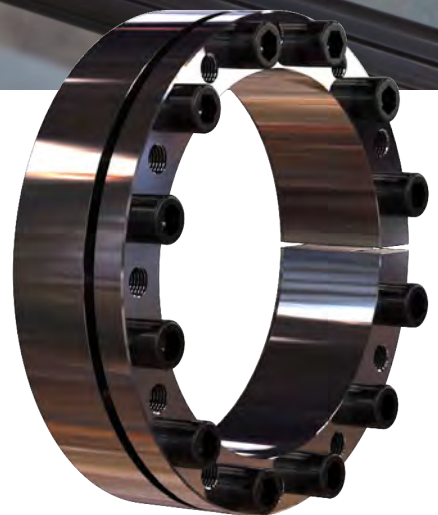

# Product overview

## Shaft/ Hub-connections

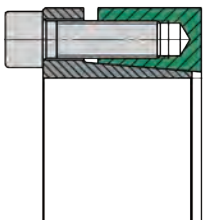

### 3003 plus / 3003

For low torque transmission.  
For medium bending moments  
Short installation length

**Page 151**

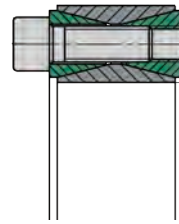

### 3020

For high torque transmission  
Low bending moment takes place  
via the hub Short installation length

**Page 173**

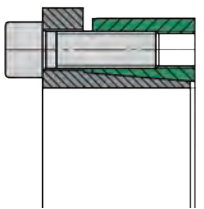

### 3006 plus / 3006

For medium torque transmission.  
For medium bending moments  
Short installation length

**Page 155**

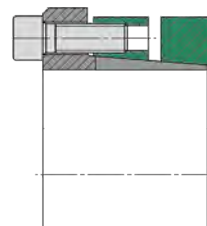

### 4006

For very high torque transmission.  
For very high bending moments.  
Wide installation length (Especially  
for pulley)

**Page 177**

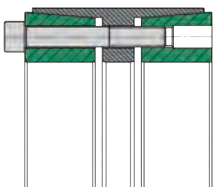

### 3012

For very high torque transmission.  
For high bending moments  
Wide installation length

**Page 159**

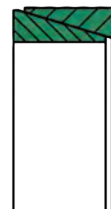

### 8006 (Locking elements)

For low torque transmission  
Small installation space

**Page 181**

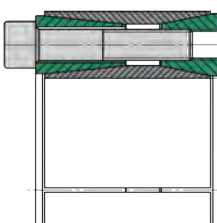

### 3014

For high torque transmission  
For medium bending moments  
Wide installation length

**Page 161**

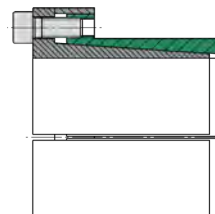

### TAS 110

For medium torque transmission.  
For medium bending moments.  
Small hub diameter

**Page 185**

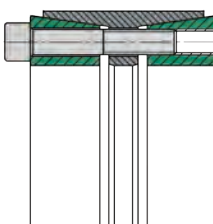

### RB,3015,3015.1

For medium torque transmission.  
For medium bending moments  
Average installation length

**Page 163**

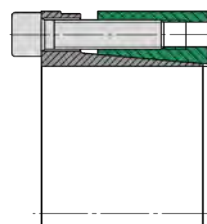

### TAS 130

For medium torque transmission.  
For medium bending moments.  
Average installation length

**Page 187**

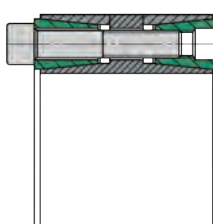

### 3015 DK, 3015.1 DK

For high torque transmission.  
For medium bending moments.  
Average installation length

**Page 169**

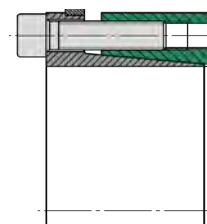

### TAS 131

For medium torque transmission.  
For medium bending moments.  
Average installation length

**Page 189**

# Description of function

## Locking devices of the types TAS ...

The main function of a locking assembly is the safe connection of a shaft to a hub by means of friction. For example, between a shaft and a gear hub. The locking assembly creates a play-free connection by expanding between the shaft and the hub. This type of connection is used mainly for transmitting torque.

It is installed by inserting the locking assembly between the components and the subsequent tightening of the screws. By using conical surfaces, the outer diameter increases and the inner diameter reduces. Radial pressure is built up. The clamping forces are provided and controlled by the screws (force-controlled). This allows the direct compensation of the clearance between shaft and hub.

The supplied locking devices are ready for installation.

To achieve proper operation with a sufficiently high coefficient of friction, the contact surfaces between shaft and hub must be clean and slightly oiled. Machine oil must be used as a lubricant. The functional surfaces of the locking assembly, threads and screw heads are prepared at the factory with oil film.

### Product data

A detailed installation manual is available on our Homepage.

### Data sheets

Contact us if a data sheet for an individual product is required.

- For CAD data of couplings, contact us directly, please.

**Rolf Gertner**  
rolf.gertner@tas-schaefer.de

or

**Mike Kemper**  
mike.kemper@tas-schaefer.de

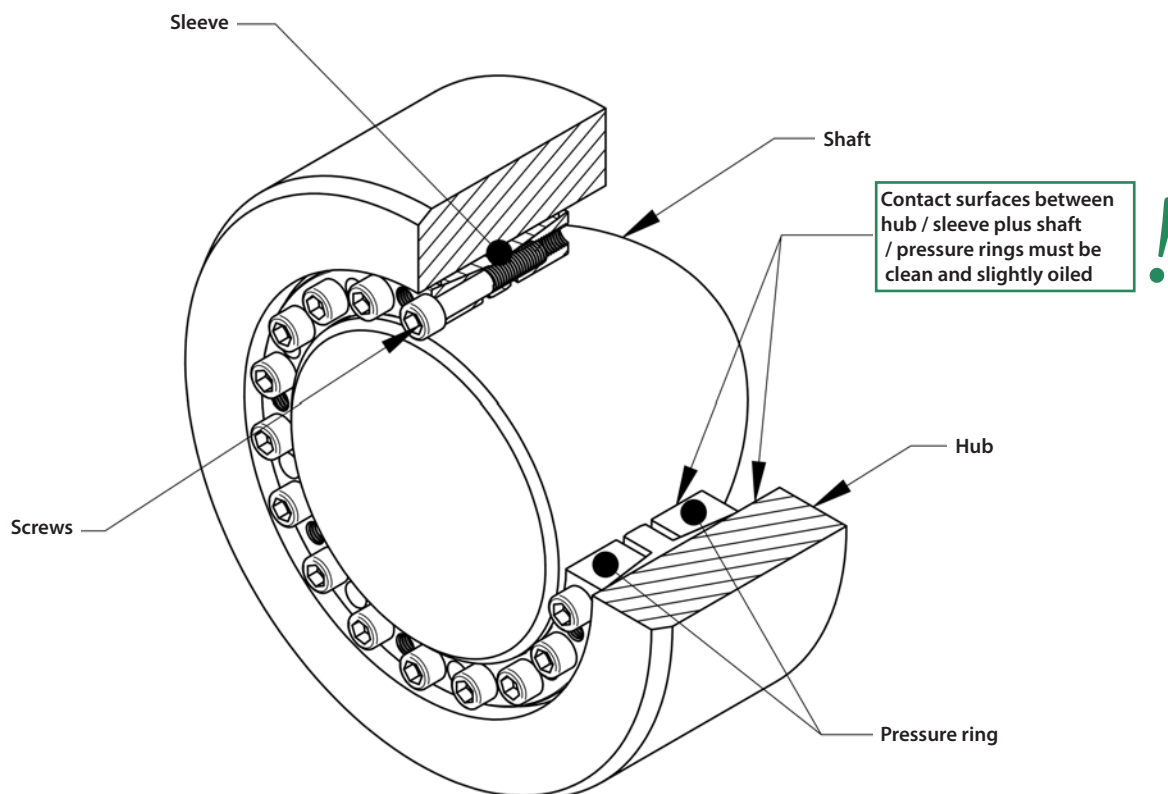



# Basic-Design

## Clamping length for locking devices

Pressure rings and bush of a locking device must be fully supported on the shaft and in the hub bore.

### Tightening torque of the clamping screws

The tightening torque values for screws given in the tables are based on a friction  $\mu_{ges} = 0,14$ . Basically the specified tightening torque  $M_A$  can be reduced to  $M_{Agew}$ , to reduce the stresses in the components. When using soft materials, as well as bored shafts, it might become necessary. By reducing  $M_A$ , the pressures of  $P_N$  and  $P_W$  and the transmittable torque  $M_t$  are also reduced. The ratio is approximately proportional and can be converted accordingly (approximately):

$$M = \frac{M_{Agew}}{M_A} M_t \quad \text{and} \quad p_{N,W} = \frac{M_{Agew}}{M_A} p_{N,W}$$

The tightening torques can not be reduced arbitrary, therefore apply the following limits:

$$M_{Agew} \geq \left( \begin{array}{l} \text{Class 8.8 : } 0,85 M_A \\ \text{Class 10.9 : } 0,70 M_A \\ \text{Class 12.9 : } 0,60 M_A \end{array} \right) \leq M_A$$

Locking assemblies of type RB, 3015.1 and 3015.1 DK are excluded because they are already provided with reduced values.

### Tolerances and surfaces

The values found in the product data, base on surface quality and tolerances according to the tables there. These values are given as recommendations.

Higher surface roughness reduces the transmissible torque and promote unwanted settlings. Larger clearance also reduces the transmissible torque.

**In case of significantly differnt values, please contact us!**

The calculation of the values, given in the catalog, are based on the following assumptions and simplification:

### Transmissible torque

A connection by locking assembly is capable of transmitting torque, bending moment and axial force. Alternatively, the transmissible torque  $M_{res}^{max}$  is specified in the product data. If such loads occur simultaneously, they must be added vectorially to form a resultant moment  $M_{res}$ . For the resultant moment applies:

$$M_{res} \leq M_{max}$$

At different load cases, these are individually checked against  $M_{max}$ !

$M_{res}$  is determined for combined load as follows:

$$M_{res} = \sqrt{M_T^2 + 2M_B^2 + (F_{Ax} \frac{d_W}{2})^2}$$

\*Basically the maximum bending moment corresponds to the maximum transmissible torque. A limitation is due to the change of the surface pressure at the edges of the connection, or by the higher loading of the locking assembly itself. Appropriate limits are found under each product. (See also under „bending moment“)

### This results in the following relationships:

#### Torque only:

The maximum torque is equivalent to  $M_{max}$ .

#### Bending moment only:

The Bending moment corresponds with the indicated portion of  $M_T$ , on the product page.

#### Axial force only:

The maximum axial force is  $M_{max} \frac{2}{d_W}$ .

Depending on the application, additional safety factors need to be considered for the individual loads!



# Basics-Calculation

## Radial Force:

Radial forces cause a change in pressure at the contact surface. In the force direction, the pressure increases on one side and is reduced accordingly on the other side. This depends on the amount of radial force and the rigidity of the parts. The following equation can be used to approximate the pressure change:

$$\Delta p_w = 0,75 \frac{F_{AX}}{d_w l_K}$$

The modified pressures  $p_{wmin,max}$  results from the following equation:

$$p_{wmin,max} = p_w \pm \Delta p_w$$

The minimum pressure  $p_{wmin}$  should be at least 30 N/mm<sup>2</sup> to avoid gap corrosion. In addition, the material must be selected for a maximum pressure  $p_{wmax}$ .

## Bending moment

Here the situation is similar to the radial forces. The pressure is greatest at the ends of the connection in this case. Again, the amount and stiffness are important. This leads to the following approximation:

$$\Delta p_{w,N} = 4,5 \frac{M_B}{d_w l_K^2}$$

As before, the modified pressures results from:

$$p_{w,Nmin,max} = p_{w,N} \pm \Delta p_{w,N}$$

The conditions for minimum and maximum pressure are the same as before. It should be noted that there could be a change in pressure due to radial force!



## Shaft and hub calculation

The catalogue contains information about the generated surface pressure of each locking assembly. Due to the generated radial pressure the hub is deformed, whereupon resilience of the shaft and surface smoothing still has to be added. For solid shafts resilience is negligible but has to be considered for hollow shafts. They are showing greater deformation and therefore greater stresses. This should be considered in addition to the other loads.

The equivalent stresses in the hub can be determined according to various hypotheses such as GEH. On the following pages you will find tables showing required hub sizes, taking pressure, shape and yield strength of hub material into consideration. The shown values for hub sizes are only valid for a solid hub cross-section! The calculation is simplified, includes no additional safety and covers the range of static loads only. Various calculation methods for different cases can be found in mechanical engineering literature. Specialized software allows the same. For complex geometry reliable results can be determined only by verified FEA.

The minimum yield strength of solid shafts should be at least  $2 * P_w$ , the yield point of hub material at least  $1 * P_N$ . These values are for orientation only, represent minimum requirements and cannot replace calculations for each application! They also do not release from doing so!

## Notch effect

Generally there is a notch effect on the components, caused by the radial pressure of the locking device. This depends mainly on the applied pressure. On the shaft the notch effect is usually much higher than at the hub, as the pressure is higher here. The factors are in the range of 1.2 to 1.8 at the shaft. This can, for example, be mitigated by appropriate design details, such as relief notches.

## Bore in the shaft (Hollow shaft)

A large bore  $d_b$  in the shaft or use of a hollow shaft, reduces the stiffness of this component against radial pressure. Basically, a bore should not be greater than  $0,3 d_w$ .

# Hub-Calculation

The K-Values can directly be taken from the tables or can be calculated as follows:

When using TAS Locking assemblies a tension is generated by the surface pressure  $P_N$  between locking assembly and hub. The required hub diameter is calculated using the same formula, as used for thick-walled hollow cylinder. The real tensions depend on the hub length and shape with respect to the length  $L$  of the locking assemblies. Depending on the type of hub, the factor  $C$  is taken into account for calculation.

$$D_N \geq D \cdot K \quad K = \sqrt{\frac{\sigma_{02} + (C \cdot p_n)}{\sigma_{02} - (C \cdot p_n)}}$$

$B \geq 2 L$

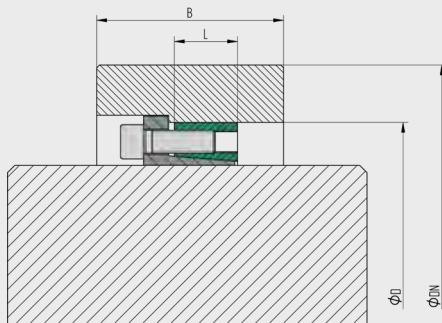

$C = 0,6$

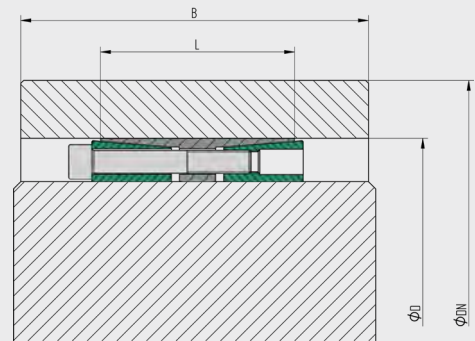

$C = 0,8$

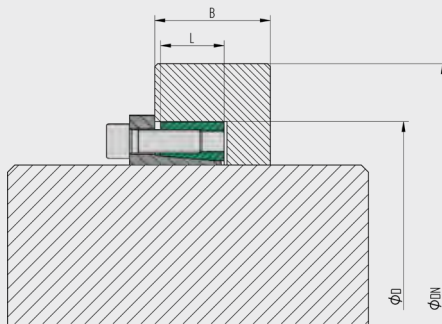

$C = 1,0$

$B \geq L$

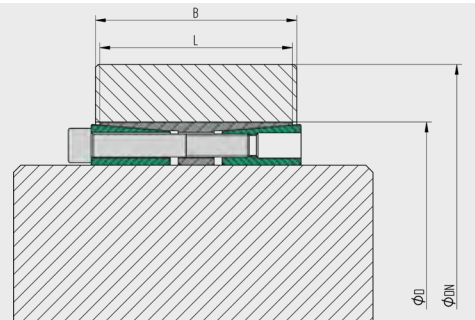
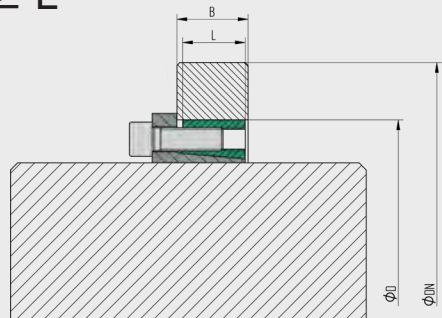



# Hub Outside Diameter

## K-Factor for hubtype with C = 0,6

### Yield strength hubmaterial (N/mm<sup>2</sup>)

$P_N$ N/mm <sup>2</sup>	Yield strength hubmaterial (N/mm <sup>2</sup> )										
	150	180	210	240	270	300	330	360	390	420	450
50	1,225	1,184	1,155	1,134	1,119	1,106	1,096	1,088	1,081	1,075	1,070
55	1,251	1,204	1,172	1,149	1,131	1,117	1,106	1,097	1,089	1,082	1,077
60	1,278	1,225	1,190	1,164	1,144	1,129	1,116	1,106	1,097	1,090	1,084
65	1,305	1,247	1,207	1,179	1,157	1,140	1,127	1,115	1,106	1,098	1,091
70	1,334	1,269	1,225	1,194	1,170	1,152	1,137	1,125	1,115	1,106	1,099
75	1,363	1,291	1,244	1,209	1,184	1,164	1,148	1,134	1,123	1,114	1,106
80	1,394	1,315	1,262	1,225	1,197	1,176	1,158	1,144	1,132	1,122	1,114
85	1,425	1,339	1,282	1,241	1,211	1,188	1,169	1,154	1,141	1,130	1,121
90	1,458	1,363	1,301	1,258	1,225	1,200	1,180	1,164	1,150	1,139	1,129
95	1,492	1,389	1,322	1,274	1,240	1,213	1,191	1,174	1,159	1,147	1,136
100	1,528	1,415	1,342	1,291	1,254	1,225	1,202	1,184	1,168	1,155	1,144
105	1,565	1,442	1,363	1,309	1,269	1,238	1,214	1,194	1,177	1,164	1,152
110	1,604	1,469	1,385	1,327	1,284	1,251	1,225	1,204	1,187	1,172	1,160
115	1,645	1,498	1,407	1,345	1,299	1,264	1,237	1,215	1,196	1,181	1,168
120	1,688	1,528	1,430	1,363	1,315	1,278	1,249	1,225	1,206	1,190	1,176
125	1,733	1,559	1,453	1,382	1,331	1,291	1,261	1,236	1,215	1,198	1,184
130	1,780	1,591	1,478	1,402	1,347	1,305	1,273	1,247	1,225	1,207	1,192
135	1,830	1,624	1,502	1,421	1,363	1,319	1,285	1,258	1,235	1,216	1,200
140	1,883	1,659	1,528	1,442	1,380	1,334	1,298	1,269	1,245	1,225	1,208
145	1,940	1,695	1,554	1,462	1,397	1,348	1,310	1,280	1,255	1,234	1,217
150	-	1,733	1,582	1,484	1,415	1,363	1,323	1,291	1,265	1,244	1,225
155	-	1,772	1,610	1,506	1,433	1,378	1,336	1,303	1,276	1,253	1,234
160	-	1,813	1,639	1,528	1,451	1,394	1,350	1,315	1,286	1,262	1,242
165	-	1,856	1,669	1,551	1,469	1,409	1,363	1,327	1,297	1,272	1,251
170	-	1,902	1,700	1,575	1,489	1,425	1,377	1,339	1,308	1,282	1,260
175	-	1,950	1,733	1,599	1,508	1,442	1,391	1,351	1,318	1,291	1,269
180	-	-	1,766	1,624	1,528	1,458	1,405	1,363	1,329	1,301	1,278
185	-	-	1,801	1,650	1,548	1,475	1,420	1,376	1,341	1,311	1,287
190	-	-	1,838	1,677	1,569	1,492	1,434	1,389	1,352	1,322	1,296
195	-	-	1,876	1,704	1,591	1,510	1,449	1,402	1,363	1,332	1,305
200	-	-	1,915	1,733	1,613	1,528	1,464	1,415	1,375	1,342	1,315
205	-	-	1,957	1,762	1,636	1,546	1,480	1,428	1,387	1,353	1,324
210	-	-	-	1,792	1,659	1,565	1,496	1,442	1,399	1,363	1,334
215	-	-	-	1,824	1,683	1,584	1,512	1,455	1,411	1,374	1,344
220	-	-	-	1,856	1,707	1,604	1,528	1,469	1,423	1,385	1,353
225	-	-	-	1,890	1,733	1,624	1,545	1,484	1,435	1,396	1,363
230	-	-	-	1,926	1,759	1,645	1,562	1,498	1,448	1,407	1,373
235	-	-	-	1,962	1,785	1,666	1,579	1,513	1,461	1,419	1,383
240	-	-	-	-	1,813	1,688	1,597	1,528	1,474	1,430	1,394
245	-	-	-	-	1,842	1,710	1,615	1,543	1,487	1,442	1,404
250	-	-	-	-	1,871	1,733	1,633	1,559	1,500	1,453	1,415

# Hub Outside Diameter

K-Factor for hubtype with C = 0,8											
$p_N$	Yield strength hubmaterial (N/mm <sup>2</sup> )										
	150	180	210	240	270	300	330	360	390	420	450
50	1,315	1,254	1,213	1,184	1,161	1,144	1,130	1,119	1,109	1,101	1,094
55	1,353	1,284	1,237	1,204	1,179	1,160	1,144	1,131	1,120	1,111	1,104
60	1,394	1,315	1,262	1,225	1,197	1,176	1,158	1,144	1,132	1,122	1,114
65	1,436	1,347	1,288	1,247	1,216	1,192	1,173	1,157	1,144	1,133	1,124
70	1,481	1,380	1,315	1,269	1,235	1,208	1,187	1,170	1,156	1,144	1,134
75	1,528	1,415	1,342	1,291	1,254	1,225	1,202	1,184	1,168	1,155	1,144
80	1,578	1,451	1,370	1,315	1,274	1,242	1,218	1,197	1,181	1,166	1,154
85	1,631	1,489	1,400	1,339	1,294	1,260	1,233	1,211	1,193	1,178	1,165
90	1,688	1,528	1,430	1,363	1,315	1,278	1,249	1,225	1,206	1,190	1,176
95	1,748	1,569	1,461	1,389	1,336	1,296	1,265	1,240	1,219	1,201	1,186
100	1,813	1,613	1,494	1,415	1,358	1,315	1,281	1,254	1,232	1,213	1,197
105	1,883	1,659	1,528	1,442	1,380	1,334	1,298	1,269	1,245	1,225	1,208
110	1,960	1,707	1,563	1,469	1,403	1,353	1,315	1,284	1,259	1,237	1,220
115	2,043	1,759	1,600	1,498	1,427	1,373	1,332	1,299	1,272	1,250	1,231
120	2,135	1,813	1,639	1,528	1,451	1,394	1,350	1,315	1,286	1,262	1,242
125	2,237	1,871	1,679	1,559	1,476	1,415	1,368	1,331	1,300	1,275	1,254
130	2,350	1,934	1,722	1,591	1,502	1,436	1,386	1,347	1,315	1,288	1,266
135	2,479	2,000	1,766	1,624	1,528	1,458	1,405	1,363	1,329	1,301	1,278
140	2,626	2,073	1,813	1,659	1,555	1,481	1,424	1,380	1,344	1,315	1,290
145	2,798	2,151	1,863	1,695	1,584	1,504	1,444	1,397	1,359	1,328	1,302
150	-	2,237	1,915	1,733	1,613	1,528	1,464	1,415	1,375	1,342	1,315
155	-	2,330	1,971	1,772	1,643	1,553	1,485	1,433	1,391	1,356	1,327
160	-	2,434	2,031	1,813	1,675	1,578	1,506	1,451	1,407	1,370	1,340
165	-	2,550	2,094	1,856	1,707	1,604	1,528	1,469	1,423	1,385	1,353
170	-	2,680	2,163	1,902	1,741	1,631	1,550	1,489	1,440	1,400	1,367
175	-	2,829	2,237	1,950	1,776	1,659	1,573	1,508	1,457	1,415	1,380
180	-	-	2,316	2,000	1,813	1,688	1,597	1,528	1,474	1,430	1,394
185	-	-	2,403	2,054	1,852	1,717	1,621	1,548	1,492	1,446	1,408
190	-	-	2,499	2,111	1,892	1,748	1,646	1,569	1,510	1,461	1,422
195	-	-	2,604	2,172	1,934	1,780	1,672	1,591	1,528	1,478	1,436
200	-	-	2,721	2,237	1,978	1,813	1,698	1,613	1,547	1,494	1,451
205	-	-	2,852	2,306	2,024	1,848	1,726	1,636	1,566	1,511	1,466
210	-	-	-	2,381	2,073	1,883	1,754	1,659	1,586	1,528	1,481
215	-	-	-	2,462	2,124	1,921	1,783	1,683	1,606	1,546	1,496
220	-	-	-	2,550	2,179	1,960	1,813	1,707	1,627	1,563	1,512
225	-	-	-	2,646	2,237	2,000	1,844	1,733	1,648	1,582	1,528
230	-	-	-	2,752	2,298	2,043	1,877	1,759	1,670	1,600	1,544
235	-	-	-	2,869	2,364	2,088	1,910	1,785	1,692	1,619	1,561
240	-	-	-	-	2,434	2,135	1,945	1,813	1,715	1,639	1,578
245	-	-	-	-	2,510	2,184	1,982	1,842	1,738	1,659	1,595
250	-	-	-	-	2,592	2,237	2,020	1,871	1,763	1,679	1,613

# Hub Outside Diameter

## K-Factor for hubtype with C = 1,0

### Yield strength hubmaterial (N/mm<sup>2</sup>)

$p_N$ N/mm <sup>2</sup>	150	180	210	240	270	300	330	360	390	420	450
50	1,415	1,331	1,275	1,236	1,207	1,184	1,165	1,151	1,138	1,128	1,119
55	1,469	1,372	1,308	1,263	1,230	1,204	1,184	1,167	1,153	1,141	1,131
60	1,528	1,415	1,342	1,291	1,254	1,225	1,202	1,184	1,168	1,155	1,144
65	1,591	1,460	1,378	1,321	1,279	1,247	1,221	1,201	1,184	1,169	1,157
70	1,659	1,508	1,415	1,351	1,304	1,269	1,241	1,218	1,199	1,184	1,170
75	1,733	1,559	1,453	1,382	1,331	1,291	1,261	1,236	1,215	1,198	1,184
80	1,813	1,613	1,494	1,415	1,358	1,315	1,281	1,254	1,232	1,213	1,197
85	1,902	1,671	1,537	1,449	1,386	1,339	1,302	1,273	1,248	1,228	1,211
90	2,000	1,733	1,582	1,484	1,415	1,363	1,323	1,291	1,265	1,244	1,225
95	2,111	1,799	1,629	1,520	1,445	1,389	1,345	1,311	1,283	1,259	1,240
100	2,237	1,871	1,679	1,559	1,476	1,415	1,368	1,331	1,300	1,275	1,254
105	2,381	1,950	1,733	1,599	1,508	1,442	1,391	1,351	1,318	1,291	1,269
110	2,550	2,036	1,789	1,641	1,542	1,469	1,415	1,372	1,337	1,308	1,284
115	2,752	2,131	1,850	1,686	1,577	1,498	1,439	1,393	1,356	1,325	1,299
120	3,000	2,237	1,915	1,733	1,613	1,528	1,464	1,415	1,375	1,342	1,315
125	3,317	2,355	1,986	1,782	1,651	1,559	1,490	1,437	1,395	1,360	1,331
130	3,742	2,490	2,062	1,835	1,691	1,591	1,517	1,460	1,415	1,378	1,347
135	4,359	2,646	2,145	1,890	1,733	1,624	1,545	1,484	1,435	1,396	1,363
140	5,386	2,829	2,237	1,950	1,776	1,659	1,573	1,508	1,457	1,415	1,380
145	7,682	3,048	2,337	2,014	1,823	1,695	1,603	1,533	1,478	1,434	1,397
150	-	3,317	2,450	2,082	1,871	1,733	1,633	1,559	1,500	1,453	1,415
155	-	3,661	2,577	2,156	1,923	1,772	1,665	1,585	1,523	1,474	1,433
160	-	4,124	2,721	2,237	1,978	1,813	1,698	1,613	1,547	1,494	1,451
165	-	4,796	2,887	2,324	2,036	1,856	1,733	1,641	1,571	1,515	1,469
170	-	5,917	3,083	2,421	2,098	1,902	1,768	1,671	1,596	1,537	1,489
175	-	8,427	3,317	2,527	2,165	1,950	1,806	1,701	1,622	1,559	1,508
180	-	-	3,606	2,646	2,237	2,000	1,844	1,733	1,648	1,582	1,528
185	-	-	3,975	2,780	2,314	2,054	1,885	1,765	1,675	1,605	1,548
190	-	-	4,473	2,933	2,398	2,111	1,928	1,799	1,703	1,629	1,569
195	-	-	5,197	3,110	2,490	2,172	1,973	1,835	1,733	1,654	1,591
200	-	-	6,404	3,317	2,592	2,237	2,020	1,871	1,763	1,679	1,613
205	-	-	9,111	3,566	2,704	2,306	2,069	1,910	1,794	1,705	1,636
210	-	-	-	3,873	2,829	2,381	2,122	1,950	1,826	1,733	1,659
215	-	-	-	4,267	2,970	2,462	2,177	1,992	1,860	1,760	1,683
220	-	-	-	4,796	3,131	2,550	2,237	2,036	1,895	1,789	1,707
225	-	-	-	5,568	3,317	2,646	2,300	2,082	1,931	1,819	1,733
230	-	-	-	6,856	3,536	2,752	2,367	2,131	1,969	1,850	1,759
235	-	-	-	9,747	3,799	2,869	2,439	2,182	2,009	1,882	1,785
240	-	-	-	-	4,124	3,000	2,517	2,237	2,050	1,915	1,813
245	-	-	-	-	4,539	3,148	2,601	2,294	2,093	1,950	1,842
250	-	-	-	-	5,100	3,317	2,693	2,355	2,139	1,986	1,871



# 3003 plus

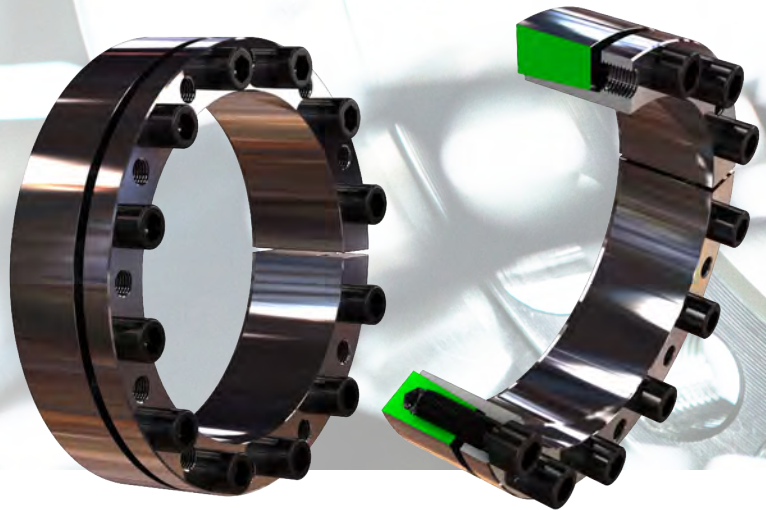
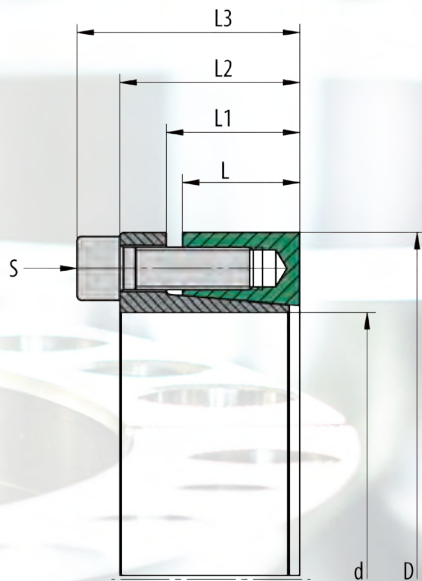

## Used symbols

d [mm]	Shaft diameter	
D [mm]	Hub inside diameter	
$M_t$ [Nm]	Max. transmittable torque	$F_{ax} = 0$
$F_{ax}$ [kN]	Max. transmittable axial force	$M_t = 0$
$p_w$ [N/mm <sup>2</sup> ]	Average pressure on the shaft	
$p_N$ [N/mm <sup>2</sup> ]	Average pressure on the hub	
L [mm]	Length of the pressure ring	
$L_1$ [mm]	Distance of the pressure ring	
$L_2$ [mm]	Width of the locking device without screws	
$L_3$ [mm]	Width of the locking device with screws	
Z	Number of clamping screws	
S	Size of the clamping screws	
$M_A$ [Nm]	Tightening torque of the clamping screws	

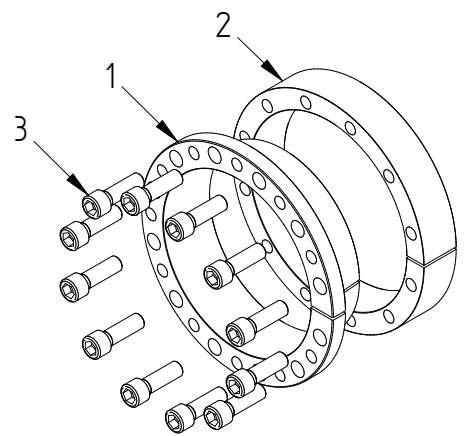

## Recommended tolerances & surfaces

Shaft	h8 / Rz10
Hub	H8 / Rz10

Pos.	Designation
1	Sleeve
2	Pressure ring
3	Screw

## Bending loads

Bending moment (share)	$M_B \text{ max} = 0,3 * M_t$
Bending angle	max. 5°

## More properties

- axial displacement during assembly
- good self-centering
- low self-locking

Ordering information: TAS 3003/d/D plus (e.g: TAS 3003/150/200 plus ... further sizes on request)

# 3003 plus

<b>d</b> mm		<b>D</b> mm	<b>M<sub>t</sub></b> Nm	<b>F<sub>ax</sub></b> kN	<b>P<sub>w</sub></b> N/mm <sup>2</sup>	<b>P<sub>N</sub></b> N/mm <sup>2</sup>	<b>Z</b> Pcs.	<b>S</b>	<b>M<sub>A</sub></b> Nm	<b>L</b> mm	<b>L<sub>1</sub></b> mm	<b>L<sub>2</sub></b> mm	<b>L<sub>3</sub></b> mm	<b>Weight</b> kg
20	x	47	360	36	281	119	5	M6 x 020	14	17	22	28	34	0,2
22	x	47	390	36	255	119	5	M6 x 020	14	17	22	28	34	0,25
24	x	50	430	36	234	112	5	M6 x 020	14	17	22	28	34	0,3
25	x	50	540	43	270	135	6	M6 x 020	14	17	22	28	34	0,3
28	x	55	600	43	241	123	6	M6 x 020	14	17	22	28	34	0,4
30	x	55	640	43	225	123	6	M6 x 020	14	17	22	28	34	0,35
32	x	60	920	58	281	150	8	M6 x 020	14	17	22	28	34	0,4
35	x	60	1000	58	257	150	8	M6 x 020	14	17	22	28	34	0,38
38	x	65	1000	58	236	138	8	M6 x 020	14	17	22	30	36	0,45
40	x	65	1100	58	225	138	8	M6 x 020	14	17	22	30	36	0,4
45	x	75	2400	110	325	195	8	M8 x 025	35	20	25	34	42	0,7
50	x	80	2700	110	293	183	8	M8 x 025	35	20	25	34,5	42,5	0,75
55	x	85	3000	110	266	172	8	M8 x 025	35	20	25	34,5	42,5	0,8
60	x	90	3300	110	244	163	8	M8 x 025	35	20	25	34,5	42,5	0,8
65	x	95	4000	124	253	173	9	M8 x 025	35	20	25	34,5	42,5	0,9
70	x	110	6000	173	274	174	8	M10 x 030	69	24	29	41	51	1,6
75	x	115	6500	173	255	167	8	M10 x 030	69	24	29	41	51	1,7
80	x	120	6900	173	239	160	8	M10 x 030	69	24	29	41	51	1,8
85	x	125	8200	195	254	172	9	M10 x 030	69	24	29	41	51	1,9
90	x	130	8700	195	239	166	9	M10 x 030	69	24	29	41	51	2,0
95	x	135	10200	217	252	177	10	M10 x 030	69	24	29	41	51	2,0
100	x	145	14200	285	291	201	9	M12 x 035	120	26	31	46	58	2,8
110	x	155	15600	285	265	188	9	M12 x 035	120	26	31	46	58	3,0
120	x	165	17100	285	242	176	9	M12 x 035	120	26	32	46	58	3,2
130	x	180	25100	387	232	168	9	M14 x 040	190	34	40	57	71	4,7
140	x	190	27100	387	216	159	9	M14 x 040	190	34	40	57	71	5,0
150	x	200	32200	430	224	168	10	M14 x 040	190	34	40	57	71	5,4
160	x	210	41200	516	252	192	12	M14 x 040	190	34	40	57	71	5,6
170	x	225	43800	516	183	138	12	M14 x 040	190	44	50	67	81	7,9
180	x	235	46400	516	173	132	12	M14 x 040	190	44	50	67	81	8,3
190	x	250	67800	714	227	172	12	M16 x 050	295	44	50	67,5	83,5	10,0
200	x	260	71300	714	215	166	12	M16 x 050	295	44	50	67,5	83,5	10,5
220	x	285	78500	714	172	133	12	M16 x 050	295	50	56	76	92	14,2
240	x	305	107000	892	197	155	15	M16 x 050	295	50	56	76	92	15,2
260	x	325	139000	1071	219	175	18	M16 x 050	295	50	56	76	92	16,4
280	x	355	159000	1136	179	141	16	M18 x 060	405	60	66	88	106	23,9
300	x	375	191000	1278	188	151	18	M18 x 060	405	60	66	88	106	25,6
320	x	405	265000	1660	186	147	18	M20 x 060	580	74	81	104	124	36,9
340	x	425	329000	1937	204	163	21	M20 x 060	580	74	81	104	124	38,9
360	x	455	374000	2081	178	141	18	M22 x 060	780	86	94	120	142	53,5
380	x	475	461000	2428	197	158	21	M22 x 060	780	86	94	120	142	56,1
400	x	495	485000	2428	187	151	21	M22 x 060	780	86	94	120	142	58,7

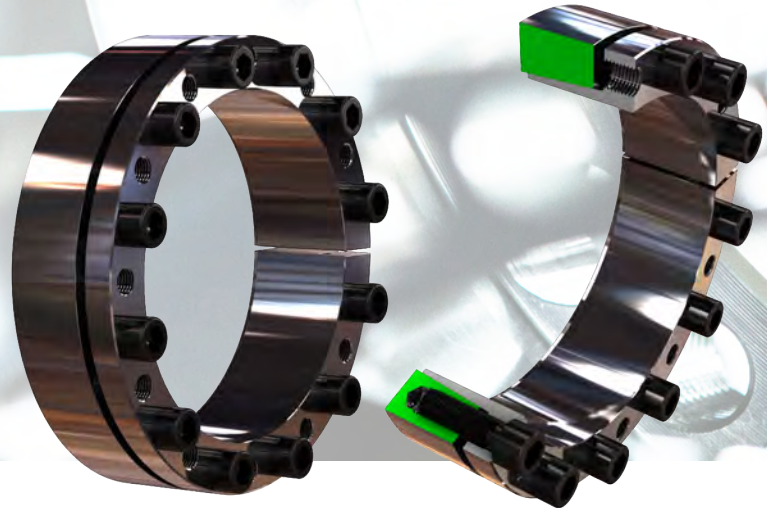
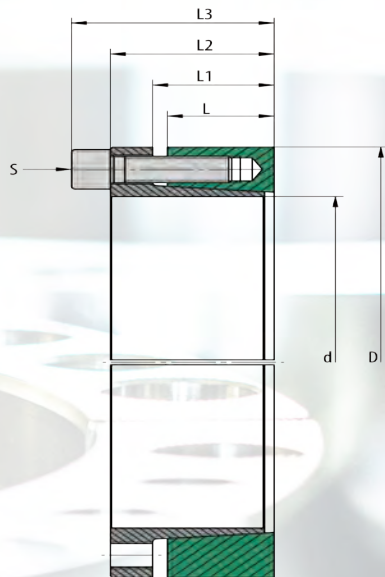

## Used symbols

d [mm]	Shaft diameter	
D [mm]	Hub inside diameter	
$M_t$ [Nm]	Max. transmittable torque	$F_{ax} = 0$
$F_{ax}$ [kN]	Max. transmittable axial force	$M_t = 0$
$p_w$ [N/mm <sup>2</sup> ]	Average pressure on the shaft	
$p_N$ [N/mm <sup>2</sup> ]	Average pressure on the hub	
L [mm]	Length of the pressure ring	
$L_1$ [mm]	Distance of the pressure ring	
$L_2$ [mm]	Width of the locking device without screws	
$L_3$ [mm]	Width of the locking device with screws	
Z	Number of clamping screws	
S	Size of the clamping screws	
$M_A$ [Nm]	Tightening torque of the clamping screws	

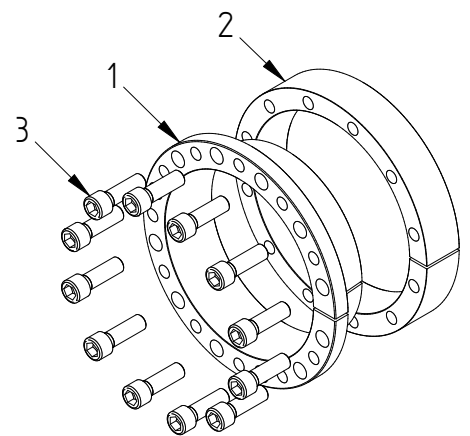

## Recommended tolerances & surfaces

Shaft	h8 / Rz10
Hub	H8 / Rz10

## Bending loads

Bending moment (share)	$M_B \text{ max} = 0,3 * M_t$
Bending angle	max. 5°

## More properties

- axial displacement during assembly
- good self-centering
- low self-locking

Ordering information: TAS 3003/d/D (e.g: TAS 3003/150/200 ... further sizes on request)

Pos.	Designation
1	Sleeve
2	Pressure ring
3	Screw



# 3003

<b>d</b> mm		<b>D</b> mm	<b>M<sub>t</sub></b> Nm	<b>F<sub>ax</sub></b> kN	<b>P<sub>w</sub></b> N/mm <sup>2</sup>	<b>P<sub>N</sub></b> N/mm <sup>2</sup>	<b>Z</b> Pcs.	<b>S</b>	<b>M<sub>A</sub></b> Nm	<b>L</b> mm	<b>L<sub>1</sub></b> mm	<b>L<sub>2</sub></b> mm	<b>L<sub>3</sub></b> mm	<b>Weight</b> kg
20	x	47	410	41	320	136	6	M6 x 020	14	17	22	28	34	0,26
22	x	47	450	41	290	136	6	M6 x 020	14	17	22	28	34	0,24
24	x	50	490	41	265	127	6	M6 x 020	14	17	22	28	34	0,27
25	x	50	510	41	255	127	6	M6 x 020	14	17	22	28	34	0,27
28	x	55	570	41	227	116	6	M6 x 020	14	17	22	28	34	0,32
30	x	55	610	41	212	115	6	M6 x 020	14	17	22	28	34	0,30
32	x	60	880	55	268	143	8	M6 x 020	14	17	22	28	34	0,37
35	x	60	960	55	245	143	8	M6 x 020	14	17	22	28	34	0,34
38	x	65	1000	53	216	126	8	M6 x 020	14	17	22	28	34	0,43
40	x	65	1100	55	215	132	8	M6 x 020	14	17	22	28	34	0,40
42	x	75	2200	105	331	185	8	M8 x 025	35	20	25	33	41	0,68
45	x	75	2400	107	314	189	8	M8 x 025	35	20	25	33	41	0,64
48	x	80	2500	104	288	173	8	M8 x 025	35	20	24	33,5	41	0,73
50	x	80	2600	104	276	172	8	M8 x 025	35	20	24	33,5	41	0,71
55	x	85	2900	105	254	165	8	M8 x 025	35	20	24	33,5	41	0,76
60	x	90	3100	103	228	152	8	M8 x 025	35	20	24	33,5	41	0,82
65	x	95	3400	105	213	146	8	M8 x 025	35	20	24	33,5	41	0,87
70	x	110	6000	171	271	172	8	M10 x 030	70	24	29	40	50	1,6
75	x	115	6400	171	252	164	8	M10 x 030	70	24	29	40	50	1,7
80	x	120	6800	170	235	157	8	M10 x 030	70	24	29	40	50	1,8
85	x	125	9000	212	275	187	10	M10 x 030	70	24	29	40	50	1,9
90	x	130	9600	213	262	181	10	M10 x 030	70	24	29	40	50	2,0
95	x	135	10200	215	250	176	10	M10 x 030	70	24	29	40	50	2,0
100	x	145	12000	240	245	169	8	M12 x 035	115	26	31	44	56	2,8
110	x	155	13000	236	219	156	8	M12 x 035	115	26	31	44	56	3,0
120	x	165	16000	267	227	165	9	M12 x 035	115	26	31	44	56	3,2
130	x	180	23000	354	212	153	12	M12 x 035	115	34	39	52	68	4,9
140	x	190	25000	357	199	147	9	M14 x 040	185	34	39	54	68	5,2
150	x	200	30000	400	208	156	10	M14 x 040	185	34	39	54	68	5,5
160	x	210	38800	485	236	180	12	M14 x 040	185	34	39	54	68	5,8
170	x	225	41300	486	172	130	12	M14 x 040	185	44	49	64	78	8,2
180	x	235	43700	486	163	125	12	M14 x 040	185	44	49	64	78	8,6
190	x	250	57700	607	193	146	15	M14 x 040	185	44	49	64	78	10,0
200	x	260	60700	607	183	141	15	M14 x 040	185	44	49	64	78	10,5

# 3006 plus

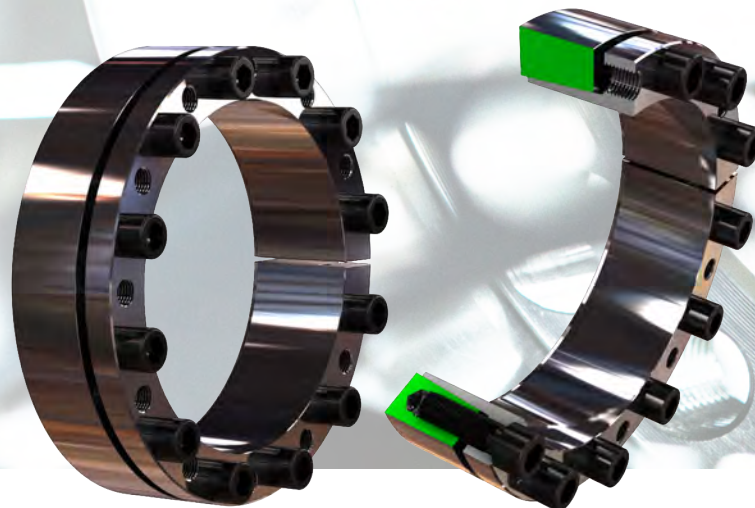
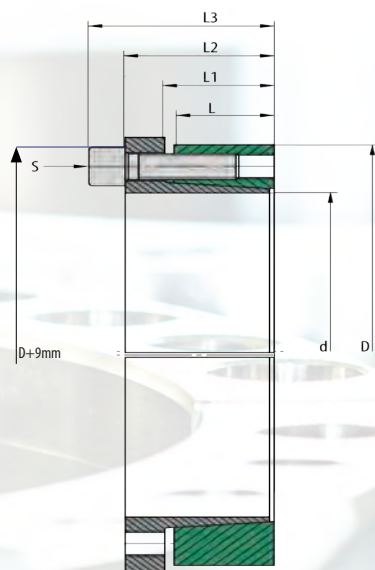

## Used symbols

d	[mm]	Shaft diameter	
D	[mm]	Hub inside diameter	
$M_t$	[Nm]	Max. transmittable torque	$F_{ax} = 0$
$F_{ax}$	[kN]	Max. transmittable axial force	$M_t = 0$
$p_w$	[N/mm <sup>2</sup> ]	Average pressure on the shaft	
$p_N$	[N/mm <sup>2</sup> ]	Average pressure on the hub	
L	[mm]	Length of the pressure ring	
$L_1$	[mm]	Distance of the pressure ring	
$L_2$	[mm]	Width of the locking device without screws	
$L_3$	[mm]	Width of the locking device with screws	
Z		Number of clamping screws	
S		Size of the clamping screws	
$M_A$	[Nm]	Tightening torque of the clamping screws	

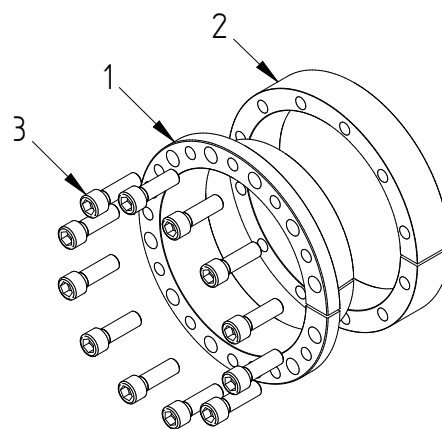

## Recommended tolerances & surfaces

Shaft	h8 / Rz10
Hub	H8 / Rz10

## Bending loads

Bending moment (share)	$M_B \text{ max} = 0,3 * M_t$
Bending angle	max. 5°

## More properties

- axial displacement during assembly
- good self-centering
- low self-locking

Ordering information: TAS 3006/d/D plus (e.g: TAS 3006/150/200 plus ... further sizes on request)

Pos.	Designation
1	Sleeve
2	Pressure ring
3	Screw

# 3006 plus

<b>d</b> mm		<b>D</b> mm	<b>M<sub>t</sub></b> Nm	<b>F<sub>ax</sub></b> kN	<b>p<sub>w</sub></b> N/mm <sup>2</sup>	<b>p<sub>N</sub></b> N/mm <sup>2</sup>	<b>Z</b> Pcs	<b>S</b>	<b>M<sub>A</sub></b> Nm	<b>L</b> mm	<b>L<sub>1</sub></b> mm	<b>L<sub>2</sub></b> mm	<b>L<sub>3</sub></b> mm	<b>Weight</b> kg
20	x	47	260	27	208	88	5	M6 x 020	17	17	22	30	36	0,3
22	x	47	290	27	189	88	5	M6 x 020	17	17	22	30	36	0,3
24	x	50	310	27	173	83	5	M6 x 020	17	17	22	30	36	0,35
25	x	50	390	32	199	100	6	M6 x 020	17	17	22	30	36	0,3
28	x	55	440	32	178	91	6	M6 x 020	17	17	22	28	34	0,4
30	x	55	470	32	166	91	6	M6 x 020	17	17	22	30	36	0,35
32	x	60	680	43	208	111	8	M6 x 020	17	17	22	28	34	0,4
35	x	60	740	43	190	111	8	M6 x 020	17	17	22	30	36	0,4
38	x	65	800	43	175	102	8	M6 x 020	17	17	22	30	36	0,5
40	x	65	850	43	166	102	8	M6 x 020	17	17	22	30	36	0,40
45	x	75	1700	79	232	139	8	M8 x 025	41	20	25	34	42	0,8
50	x	80	1900	79	209	131	8	M8 x 025	41	20	25	34	42	0,8
55	x	85	2100	79	190	123	8	M8 x 025	41	20	25	34	42	0,75
60	x	90	2300	79	174	116	8	M8 x 025	41	20	25	34	42	0,95
65	x	95	2800	89	181	124	9	M8 x 025	41	20	25	34	42	1,0
70	x	110	4500	130	205	131	8	M10 x 030	83	24	29	41	51	1,8
75	x	115	4800	130	192	125	8	M10 x 030	83	24	30	42	52	1,9
80	x	120	5100	130	180	120	8	M10 x 030	83	24	30	41	51	2,0
85	x	125	6200	146	190	129	9	M10 x 030	83	24	30	41	51	2,1
90	x	130	6500	146	180	124	9	M10 x 030	83	24	29	41	51	2,2
95	x	135	7700	162	189	133	10	M10 x 030	83	24	29	41	51	2,3
100	x	145	10800	216	220	152	9	M12 x 035	145	26	32	46	58	3,0
110	x	155	11800	216	200	142	9	M12 x 035	145	26	32	46	58	3,2
120	x	165	12900	216	184	134	9	M12 x 035	145	26	31	46	58	3,4
130	x	180	18800	290	174	126	9	M14 x 040	230	34	40	57	71	5,1
140	x	190	20200	290	162	119	9	M14 x 040	230	34	40	57	71	5,4
150	x	200	24100	322	168	126	10	M14 x 040	230	34	40	57	71	5,8
160	x	210	30900	387	189	144	12	M14 x 040	230	34	40	57	71	6,0
170	x	225	32800	387	137	104	12	M14 x 040	230	44	50	67	81	8,3
180	x	235	34700	387	129	99	12	M14 x 040	230	44	50	67	81	8,8
190	x	250	50400	531	168	128	12	M16 x 050	355	44	50	67	83	10,3
200	x	260	53000	531	160	123	12	M16 x 050	355	44	50	67	83	10,8
220	x	285	58300	531	128	99	12	M16 x 050	355	50	56	75	91	14,8
240	x	305	79500	663	147	115	15	M16 x 050	355	50	56	75	91	16,0
260	x	325	103000	796	162	130	18	M16 x 050	355	50	56	76	93	17,2
280	x	355	120000	858	135	107	16	M18 x 060	485	60	66	87	105	25,0
300	x	375	144000	965	142	114	18	M18 x 060	485	60	66	87	105	26,4
320	x	405	198000	1241	139	110	18	M20 x 060	690	74	81	104	124	36,85
340	x	425	246000	1447	153	122	21	M20 x 060	690	74	81	104	124	38,89
360	x	455	278000	1548	133	105	18	M22 x 060	930	86	94	120	142	53,46
380	x	475	343000	1805	147	117	21	M22 x 060	930	86	94	120	142	56,09
400	x	495	361000	1805	139	112	21	M22 x 060	930	86	94	120	142	58,71



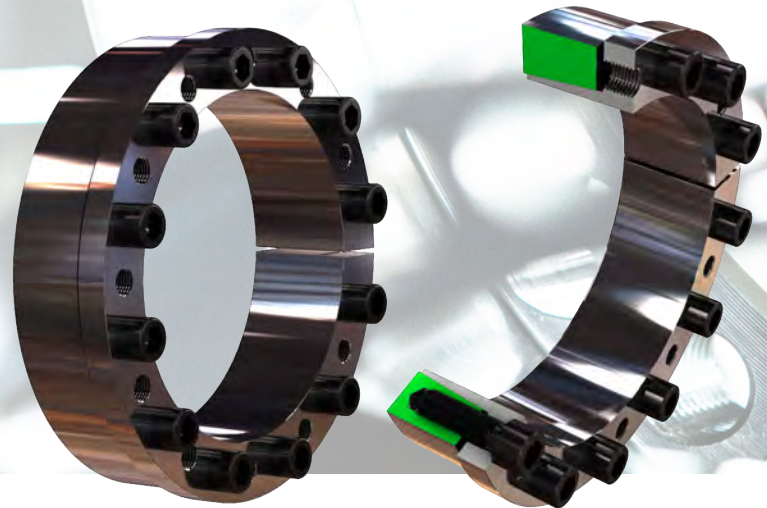
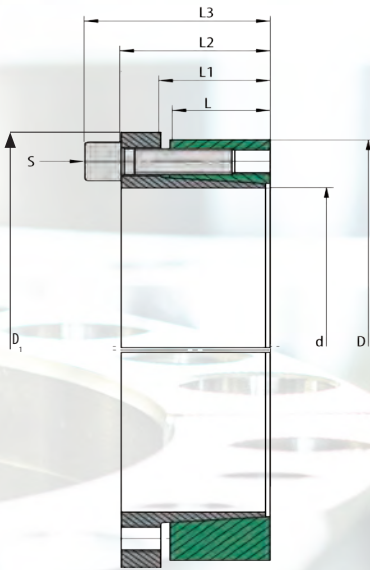

## Used symbols

d [mm]	Shaft diameter	
D [mm]	Hub inside diameter	
$M_t$ [Nm]	Max. transmittable torque	$F_{ax} = 0$
$F_{ax}$ [kN]	Max. transmittable axial force	$M_t = 0$
$p_w$ [N/mm <sup>2</sup> ]	Average pressure on the shaft	
$p_N$ [N/mm <sup>2</sup> ]	Average pressure on the hub	
L [mm]	Length of the pressure ring	
$L_1$ [mm]	Distance of the pressure ring	
$L_2$ [mm]	Width of the locking device without screws	
$L_3$ [mm]	Width of the locking device with screws	
Z	Number of clamping screws	
S	Size of the clamping screws	
$M_A$ [Nm]	Tightening torque of the clamping screws	

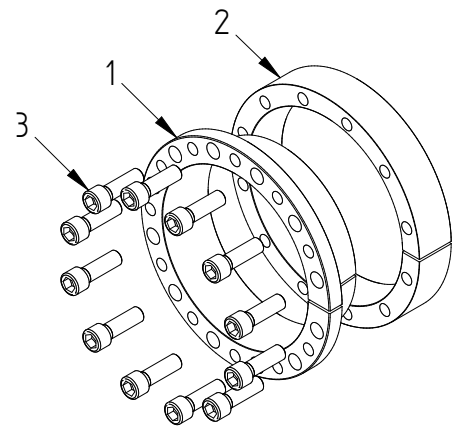

## Recommended tolerances & surfaces

Shaft	h8 / Rz10
Hub	H8 / Rz10

## Bending loads

Bending moment (share)	$M_B \text{ max} = 0,3 * M_t$
Bending angle	max. 5°

## More properties

- axial displacement during assembly
- good self-centering
- low self-locking

Ordering information: TAS 3006/d/D (e.g: TAS 3006/150/200 ...  
further sizes on request)

Pos.	Designation
1	Sleeve
2	Pressure ring
3	Screw

# 3006

<b>d</b> mm	<b>D</b> mm	<b>D1</b> mm	<b>M<sub>t</sub></b> Nm	<b>F<sub>ax</sub></b> kN	<b>p<sub>w</sub></b> N/mm <sup>2</sup>	<b>p<sub>N</sub></b> N/mm <sup>2</sup>	<b>Z</b> Pcs.	<b>S</b>	<b>M<sub>A</sub></b> Nm	<b>L</b> mm	<b>L<sub>1</sub></b> mm	<b>L<sub>2</sub></b> mm	<b>L<sub>3</sub></b> mm	<b>Weight</b> kg
20	x 47	53	320	32	250	106	6	M6 x 020	17	17	22	28	34	0,28
22	x 47	53	350	32	226	106	6	M6 x 020	17	17	22	28	34	0,27
24	x 50	56	390	33	211	101	6	M6 x 020	17	17	22	28	34	0,30
25	x 50	56	400	32	200	100	6	M6 x 020	17	17	22	28	34	0,29
28	x 55	61,4	450	32	179	91	6	M6 x 020	17	17	22	28	34	0,32
30	x 55	61,4	490	33	170	93	6	M6 x 020	17	17	22	28	34	0,33
32	x 60	67	700	44	213	114	8	M6 x 020	17	17	22	28	34	0,37
35	x 60	67	760	43	194	113	8	M6 x 020	17	17	22	28	34	0,37
38	x 65	72	820	43	177	104	8	M6 x 020	17	17	22	28	34	0,43
40	x 65	72	870	44	170	104	8	M6 x 020	17	17	22	28	34	0,40
42	x 75	84	1700	81	256	143	8	M8 x 025	41	20	25	33	41	0,69
45	x 75	84	1800	80	236	141	8	M8 x 025	41	20	25	33	41	0,64
48	x 80	89	1900	79	219	131	8	M8 x 025	41	20	24	33,5	41	0,74
50	x 80	89	2000	80	212	133	8	M8 x 025	41	20	24	33,5	41	0,70
55	x 85	94	2200	80	193	125	8	M8 x 025	41	20	24	33,5	41	0,75
60	x 90	99	2400	80	177	118	8	M8 x 025	41	20	24	33,5	41	0,80
65	x 95	104	2600	80	163	112	8	M8 x 025	41	20	24	33,5	41	0,86
70	x 110	119	4600	131	208	132	8	M10 x 030	83	24	29	40	50	1,60
75	x 115	124	5000	133	196	128	8	M10 x 030	83	24	29	40	50	1,69
80	x 120	129	5300	133	183	122	8	M10 x 030	83	24	29	40	50	1,73
85	x 125	134	7000	165	214	146	10	M10 x 030	83	24	29	40	50	1,81
90	x 130	139	7400	164	202	140	10	M10 x 030	83	24	29	40	50	1,95
95	x 135	144	7800	164	191	134	10	M10 x 030	83	24	29	40	50	2,04
100	x 145	154	9700	194	198	136	8	M12 x 035	145	26	31	44	56	2,72
110	x 155	164	10700	195	180	128	8	M12 x 035	145	26	31	44	56	2,94
120	x 165	174	13100	218	186	135	9	M12 x 035	145	26	31	44	56	3,24
130	x 180	189	19000	292	175	127	12	M12 x 035	145	34	39	52	68	4,87
140	x 190	199	20500	293	163	120	9	M14 x 040	230	34	39	54	68	5,19
150	x 200	209	24500	327	170	127	10	M14 x 040	230	34	39	54	68	5,50
160	x 210	219	31300	391	191	145	12	M14 x 040	230	34	39	54	68	5,82
170	x 225	234	33200	391	139	105	12	M14 x 040	230	44	49	64	78	8,17
180	x 235	244	35000	389	130	100	12	M14 x 040	230	44	49	64	78	8,58
190	x 250	259	46500	489	155	118	15	M14 x 040	230	44	49	64	78	9,93
200	x 260	269	49000	490	148	114	15	M14 x 040	230	44	49	64	78	10,38

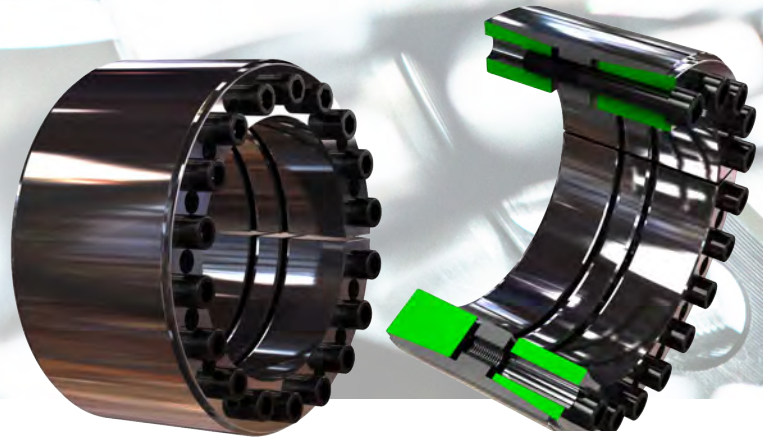
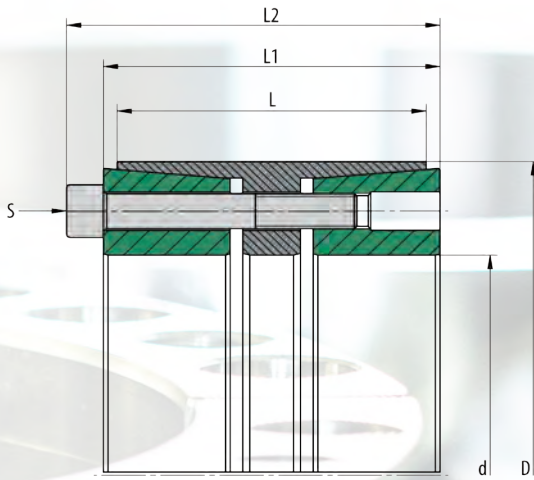

## Used symbols

$d$	[mm]	Shaft diameter	
$D$	[mm]	Hub inside diameter	
$M_t$	[Nm]	Max. transmittable torque	$F_{ax} = 0$
$F_{ax}$	[kN]	Max. transmittable axial force	$M_t = 0$
$p_w$	[N/mm <sup>2</sup> ]	Average pressure on the shaft	
$p_N$	[N/mm <sup>2</sup> ]	Average pressure on the hub	
$L$	[mm]	Length of the sleeve	
$L_1$	[mm]	Width of the locking device without screws	
$L_2$	[mm]	Width of the locking device with screws	
$Z$		Number of clamping screws	
$S$		Size of the clamping screws	
$M_A$	[Nm]	Tightening torque of the clamping screws	

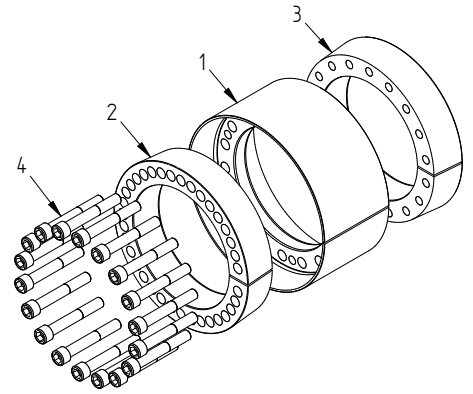

## Recommended tolerances & surfaces

Shaft	h8 / Rz10
Hub	H8 / Rz10

## Bending loads

Bending moment (share)	$M_B \max = 0,4 * M_t$
Bending angle	max. 5'

## More properties

- low axial displacement during assembly
- very good self-centering
- high self-locking

Pos.	Benennung
1	Sleeve
2	Pressure ring 1
3	Pressure ring 2
4	Screw

Ordering information: TAS 3012/d/D (e.g: TAS 3012/150/200 ...  
further sizes on request)



# 3012

<b>d</b> mm	<b>D</b> mm	<b>M<sub>t</sub></b> Nm	<b>F<sub>ax</sub></b> kN	<b>p<sub>w</sub></b> N/mm <sup>2</sup>	<b>p<sub>N</sub></b> N/mm <sup>2</sup>	<b>Z</b> Pcs.	<b>S</b>	<b>M<sub>A</sub></b> Nm	<b>L</b> mm	<b>L<sub>1</sub></b> mm	<b>L<sub>2</sub></b> mm	<b>Weight</b> kg
25	x 50	660	53	153	63	5	M6 x 045	17	45	53	59	0,5
30	x 55	950	64	153	68	6	M6 x 045	17	45	55	61	0,6
35	x 60	1300	75	153	73	7	M6 x 045	17	45	55	61	0,6
38	x 65	1600	85	161	77	8	M6 x 045	17	45	55	61	0,7
40	x 65	1700	85	153	77	8	M6 x 045	17	45	55	61	0,7
45	x 75	3100	138	239	111	7	M8 x 050	41	44	54	62	1,0
50	x 80	3900	158	190	93	8	M8 x 050	41	56	64	72	1,2
55	x 85	4800	177	194	99	9	M8 x 050	41	56	64	72	1,3
60	x 90	5900	197	198	104	10	M8 x 050	41	56	64	72	1,4
65	x 95	6400	197	183	98	10	M8 x 050	41	56	64	72	1,5
70	x 110	11300	325	220	112	10	M10 x 060	83	70	78	88	2,8
80	x 120	14200	357	212	113	11	M10 x 060	83	70	78	88	3,1
90	x 130	17500	390	205	114	12	M10 x 060	83	70	78	88	3,4
100	x 145	26400	528	200	107	11	M12 x 080	145	90	100	112	5,5
110	x 155	31600	576	198	110	12	M12 x 080	145	90	100	112	5,9
120	x 165	40300	672	212	120	14	M12 x 080	145	90	100	112	7,1
130	x 180	50200	773	188	110	12	M14 x 090	230	104	116	130	9,0
140	x 190	63100	902	203	121	14	M14 x 090	230	104	116	130	9,4
150	x 200	72400	966	203	123	15	M14 x 090	230	104	116	130	10,0
160	x 210	82400	1031	203	125	16	M14 x 090	230	104	118	132	10,6
170	x 225	105000	1238	176	109	14	M16 x 110	355	134	146	162	16,1
180	x 235	119000	1327	178	112	15	M16 x 110	355	134	146	162	16,8
190	x 250	134000	1415	180	112	16	M16 x 110	355	134	146	162	19,7
200	x 260	141000	1415	171	108	16	M16 x 110	355	134	146	162	22,8
220	x 285	175000	1592	174	111	18	M16 x 110	355	134	146	162	24,8
240	x 305	212000	1769	178	115	20	M16 x 110	355	134	146	162	26,6
260	x 325	229000	1769	164	108	20	M16 x 110	355	134	146	162	38,8
280	x 355	347000	2481	178	112	18	M20 x 130	690	165	177	197	42,8
300	x 375	413000	2757	185	118	20	M20 x 130	690	165	177	197	45,4
320	x 405	463000	2895	182	115	21	M20 x 130	690	165	177	197	62,7
340	x 425	515000	3033	174	115	22	M20 x 130	690	165	177	197	66,1
360	x 455	649000	3611	174	111	21	M22 x 150	930	190	202	224	90,7
380	x 475	718000	3783	173	111	22	M22 x 150	930	190	202	224	95,1
400	x 495	825000	4127	179	116	24	M22 x 150	930	190	202	224	100
420	x 515	866000	4127	170	112	24	M22 x 150	930	190	202	224	104
440	x 535	907000	4127	163	108	24	M22 x 150	930	190	202	224	109
460	x 555	949000	4127	156	104	24	M22 x 150	930	190	202	224	113
480	x 575	1155000	4814	174	117	28	M22 x 150	930	190	202	224	117
500	x 595	1203000	4814	167	113	28	M22 x 150	930	190	202	224	122
520	x 615	1341000	5158	172	117	30	M22 x 150	930	190	202	224	126
540	x 635	1437000	5325	171	117	30	M22 x 150	930	190	202	224	131
560	x 655	1590000	5680	176	121	32	M22 x 150	930	190	202	224	135
580	x 675	1698000	5857	175	121	33	M22 x 150	930	190	202	224	140
600	x 695	1757000	5857	169	118	33	M22 x 150	930	190	202	224	144
620	x 715	1870000	6035	169	118	34	M22 x 150	930	190	202	224	149

# 3014

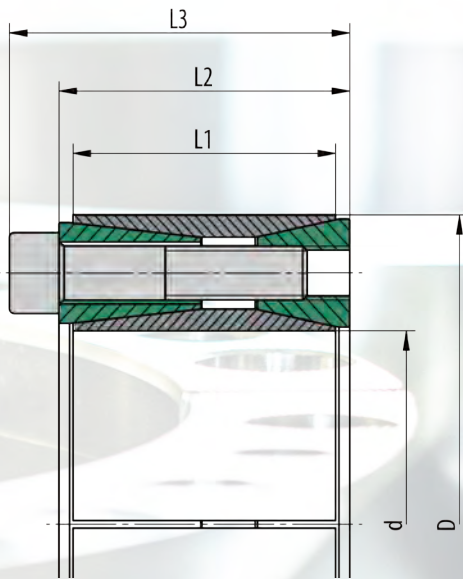

## Used symbols

$d$ [mm]	Shaft diameter
$D$ [mm]	Hub inside diameter
$M_t$ [Nm]	Max. transmittable torque $F_{ax} = 0$
$F_{ax}$ [kN]	Max. transmittable axial force $M_t = 0$
$p_w$ [N/mm <sup>2</sup> ]	Average pressure on the shaft
$p_N$ [N/mm <sup>2</sup> ]	Average pressure on the hub
$L_1$ [mm]	Length of the sleeve inside and outside
$L_2$ [mm]	Width of the locking device without screws
$L_3$ [mm]	Width of the locking device with screws
$Z$	Number of clamping screws
$S$	Size of the clamping screws
$M_A$ [Nm]	Tightening torque of the clamping screws

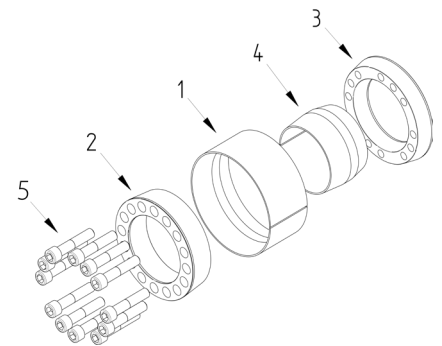

## Recommended tolerances & surfaces

Shaft	k9-h9 / Rz10
Hub	N9-H9 / Rz10

## Bending loads

Bending moment (share)	$M_B \max = 0,3 * M_t$
Bending angle	max. 5°

## More properties

- no axial displacement during assembly
- very good self-centering
- low self-locking

In order to be able to dismantle these clamping sets, the back pressure ring pos. 3 must bear against a stop !

Ordering information: TAS 3014/d/D (e.g: TAS 3014/150/200 ... further sizes on request)

# 3014

<b>d</b> mm	<b>x</b>	<b>D</b> mm	<b>M<sub>t</sub></b> Nm	<b>F<sub>ax</sub></b> kN	<b>p<sub>w</sub></b> N/mm <sup>2</sup>	<b>p<sub>N</sub></b> N/mm <sup>2</sup>	<b>Z</b> Pcs.	<b>S</b>	<b>M<sub>A</sub></b> Nm	<b>L<sub>1</sub></b> mm	<b>L<sub>2</sub></b> mm	<b>L<sub>3</sub></b> mm	<b>Weight</b> kg
70	x	120	7136	204	206	120	8	M12 x 055	145	56	62	74	3,2
80	x	130	12233	306	271	166	12	M12 x 055	145	56	62	74	3,6
90	x	140	13762	306	240	155	12	M12 x 055	145	56	62	74	3,9
100	x	160	20967	419	219	137	12	M14 x 070	235	72	82	96	7,0
110	x	170	26908	489	233	151	14	M14 x 070	235	72	82	96	7,5
120	x	180	31450	524	228	152	15	M14 x 070	235	72	82	96	8,0
130	x	190	34071	524	211	144	15	M14 x 070	235	72	82	96	8,5
140	x	200	41585	594	222	155	17	M14 x 070	235	72	82	96	9,1
150	x	210	47176	629	219	151	18	M14 x 070	235	72	82	96	9,6
160	x	230	65643	821	231	161	17	M16 x 080	365	84	94	110	13,8
170	x	240	73848	869	230	163	18	M16 x 080	365	84	94	110	14,5
180	x	250	86880	965	241	174	20	M16 x 080	365	84	94	110	15,3
190	x	260	96292	1014	240	175	21	M16 x 080	365	84	94	110	16,0
200	x	270	111013	1110	250	185	23	M16 x 080	365	84	94	110	17,0
220	x	300	135579	1233	198	145	21	M18 x 100	500	105	116	134	27,0
240	x	320	169033	1408	208	156	24	M18 x 100	500	105	116	134	29,2
260	x	340	183119	1409	192	147	24	M18 x 100	500	105	116	134	31,3
280	x	370	252994	1807	194	147	24	M20 x 120	710	125	136	156	45,0
300	x	390	271065	1807	181	139	24	M20 x 120	710	125	136	156	47,7





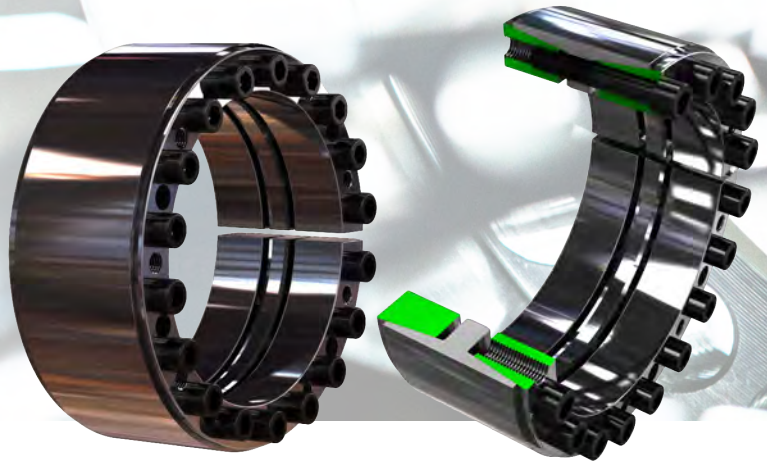
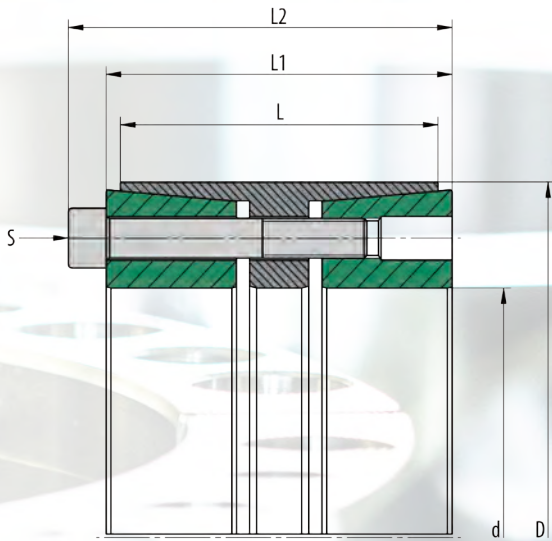

## Used symbols

$d$	[mm]	Shaft diameter	
$D$	[mm]	Hub inside diameter	
$M_t$	[Nm]	Max. transmittable torque	$F_{ax} = 0$
$F_{ax}$	[kN]	Max. transmittable axial force	$M_t = 0$
$p_w$	[N/mm <sup>2</sup> ]	Average pressure on the shaft	
$p_n$	[N/mm <sup>2</sup> ]	Average pressure on the hub	
$L$	[mm]	Length of the sleeve	
$L_1$	[mm]	Width of the locking device without screws	
$L_2$	[mm]	Width of the locking device with screws	
$Z$		Number of clamping screws	
$S$		Size of the clamping screws	
$M_A$	[Nm]	Tightening torque of the clamping screws	

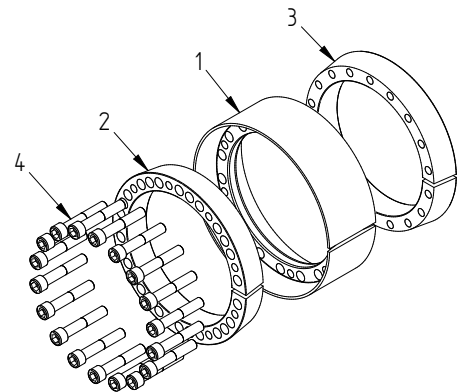

## Recommended tolerances & surfaces

Shaft	h8 / Rz10
Hub	H8 / Rz10

## Bending loads

Bending moment (share)	$M_B \text{ max} = 0,4 * M_t$
Bending angle	max. 5°

## More properties

- low axial displacement during assembly
- good self-centering
- low self-locking

Pos.	Designation
1	Sleeve
2	Pressure ring 1
3	Pressure ring 2
4	Screw

Ordering information: TAS RB/d/D (e.g. TAS RB/150/200 ...  
further sizes on request)

<b>d</b> mm		<b>D</b> mm	<b>M<sub>t</sub></b> Nm	<b>F<sub>ax</sub></b> kN	<b>p<sub>w</sub></b> N/mm <sup>2</sup>	<b>p<sub>N</sub></b> N/mm <sup>2</sup>	<b>Z</b> Pcs.	<b>S</b>	<b>M<sub>A</sub></b> Nm	<b>L</b> mm	<b>L<sub>1</sub></b> mm	<b>L<sub>2</sub></b> mm	<b>Weight</b> kg
100	x	145	7800	157	80	46	7	M10 x 060	83	62	74	84	4,2
110	x	155	9800	180	83	50	8	M10 x 060	83	62	74	84	4,6
120	x	165	12100	202	83	51	9	M10 x 060	83	64	76	86	5,1
130	x	180	14600	225	85	52	10	M10 x 060	83	64	76	86	6,1
140	x	190	17300	247	84	52	11	M10 x 060	83	66	78	88	6,7
150	x	200	18500	247	73	53	11	M10 x 070	83	62	84	94	6,7
160	x	210	23900	299	75	48	9	M12 x 075	145	78	92	104	8,9
170	x	225	28200	332	79	50	10	M12 x 075	145	78	92	104	10,4
180	x	235	29800	332	79	50	10	M12 x 070	145	75	86	100	10,6
190	x	250	38100	401	67	50	9	M14 x 080	230	85	112	126	13,8
200	x	260	44500	446	70	54	10	M14 x 090	230	85	112	126	14,5
220	x	285	53900	490	74	54	11	M14 x 090	230	85	112	126	17,2
240	x	305	66000	551	76	56	9	M16 x 090	355	85	112	128	18,6
260	x	325	87400	673	75	57	11	M16 x 100	355	97	124	140	22,7
280	x	355	111000	795	72	55	13	M16 x 090	355	108	136	152	31,7
300	x	375	119000	795	73	52	13	M16 x 090	355	108	127	143	33,7
320	x	405	138000	865	65	47	15	M16 x 090	355	120	142	142	45,6
340	x	425	142000	841	60	44	15	M16 x 090	355	120	142	158	48,1
360	x	455	195000	1088	67	49	16	M18 x 130	485	130	160	178	62,1
380	x	475	235000	1240	67	48	13	M20 x 130	690	145	172	192	72,6
400	x	495	305000	1526	78	56	16	M20 x 130	690	145	172	192	76,0
420	x	515	320000	1526	69	54	16	M20 x 130	690	145	180	190	79,4
440	x	545	377000	1717	74	52	18	M20 x 130	690	160	180	200	102,0
460	x	565	394000	1717	71	56	18	M20 x 130	690	145	180	200	96,2
480	x	585	457000	1907	75	54	20	M20 x 130	690	160	180	200	110,3
500	x	605	476000	1907	72	60	20	M20 x 130	690	140	180	200	100,1
520	x	630	556000	2141	73	50	18	M22 x 140	930	180	202	224	140,4
540	x	650	610000	2260	74	51	19	M22 x 140	930	180	202	224	145,3
560	x	670	666000	2379	75	52	20	M22 x 140	930	180	202	224	150,2
580	x	690	632000	2180	66	47	20	M22 x 140	930	180	208	208	155,0
600	x	710	653000	2180	64	45	20	M22 x 140	930	180	208	230	159,9
620	x	730	585000	1888	78	62	21	M20 x 090	930	110	140	140	100,7

# 3015

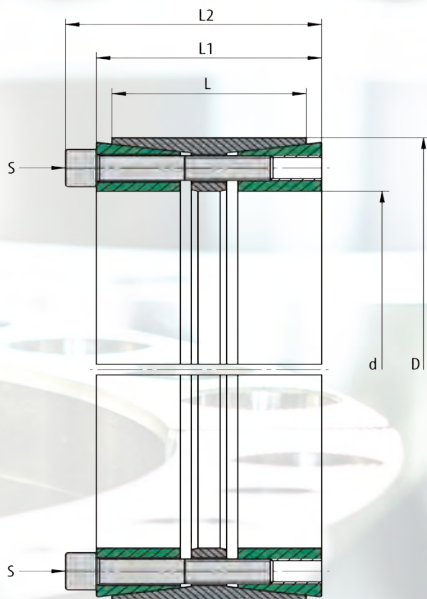

## Used symbols

$d$	[mm]	Shaft diameter	
$D$	[mm]	Hub inside diameter	
$M_t$	[Nm]	Max. transmittable torque	$F_{ax} = 0$
$F_{ax}$	[kN]	Max. transmittable axial force	$M_t = 0$
$p_w$	[N/mm <sup>2</sup> ]	Average pressure on the shaft	
$p_h$	[N/mm <sup>2</sup> ]	Average pressure on the hub	
$L$	[mm]	Length of the sleeve	
$L_1$	[mm]	Width of the locking device without screws	
$L_2$	[mm]	Width of the locking device with screws	
$Z$		Number of clamping screws	
$S$		Size of the clamping screws	
$M_A$	[Nm]	Tightening torque of the clamping screws	

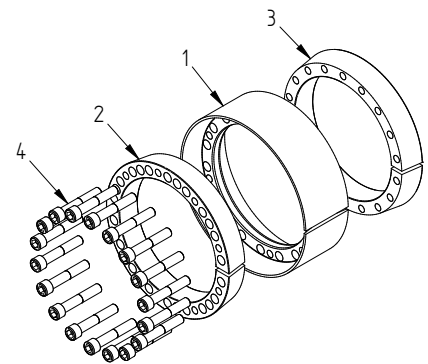

## Recommended tolerances & surfaces

Shaft	h8 / Rz10
Hub	H8 / Rz10

## Bending loads

Bending moment (share)	$M_B \text{ max} = 0,3 * M_t$
Bending angle	max. 5°

## More properties

- low axial displacement during assembly
- good self-centering
- low self-locking

Pos.	Designation
1	Sleeve
2	Pressure ring 1
3	Pressure ring 2
4	Screw

Ordering information: TAS 3015/d/D (e.g: TAS 3015/150/200 ...  
further sizes on request)



# 3015

<b>d</b> mm		<b>D</b> mm	<b>M<sub>t</sub></b> Nm	<b>F<sub>ax</sub></b> kN	<b>p<sub>w</sub></b> N/mm <sup>2</sup>	<b>p<sub>N</sub></b> N/mm <sup>2</sup>	<b>Z</b> Pcs.	<b>S</b>	<b>M<sub>A</sub></b> Nm	<b>L</b> mm	<b>L<sub>1</sub></b> mm	<b>L<sub>2</sub></b> mm	<b>Weight</b> kg
70	x	110	6900	197	187	95	8	M10 x 055	83	50	60	70	2,2
80	x	120	9800	247	204	109	10	M10 x 055	83	50	60	70	2,5
90	x	130	12200	271	200	111	11	M10 x 055	83	50	60	70	2,8
100	x	145	18200	364	201	111	10	M12 x 060	145	60	70	82	4,0
110	x	155	20000	364	183	104	10	M12 x 060	145	60	70	82	4,4
120	x	165	24000	401	185	107	11	M12 x 060	145	60	70	82	4,6
130	x	180	33100	510	193	116	14	M12 x 065	145	65	79	91	6,2
140	x	190	38200	547	192	117	15	M12 x 065	145	65	79	91	6,6
150	x	200	40900	547	179	112	15	M12 x 065	145	65	79	91	7,0
160	x	210	46600	583	179	113	16	M12 x 065	145	65	79	91	7,5
170	x	225	62300	734	179	111	15	M14 x 075	230	78	92	106	10,3
180	x	235	66000	734	169	106	15	M14 x 075	230	78	92	106	10,9
190	x	250	74300	782	144	94	16	M14 x 080	230	88	102	116	14,2
200	x	260	97100	972	170	113	18	M14 x 080	230	88	102	116	14,8
220	x	285	110000	1007	148	98	15	M16 x 090	355	96	108	124	19,0
240	x	305	161000	1342	181	122	20	M16 x 090	355	96	108	124	20,2
260	x	325	174000	1342	167	114	20	M16 x 090	355	96	108	124	21,8
280	x	355	219000	1569	196	122	15	M20 x 100	690	96	110	130	28,4
300	x	375	251000	1674	195	123	16	M20 x 100	690	96	110	130	30,0
320	x	405	334000	2092	181	111	20	M20 x 110	690	124	136	156	44,2
340	x	425	355000	2092	170	105	20	M20 x 110	690	124	136	156	49,7
360	x	455	469000	2610	160	109	20	M22 x 130	930	140	157	179	66,8
380	x	475	495000	2610	152	104	20	M22 x 130	930	140	157	179	70,0
400	x	495	574000	2871	159	110	22	M22 x 130	930	140	157	179	73,4
420	x	515	657000	3132	165	115	24	M22 x 130	930	140	157	179	76,7
440	x	535	689000	3132	157	111	24	M22 x 130	930	140	157	179	79,9
460	x	555	720000	3132	151	107	24	M22 x 130	930	140	157	179	83,2
480	x	575	782000	3262	150	108	25	M22 x 130	930	140	157	179	82,8
500	x	595	815000	3262	144	104	25	M22 x 130	930	140	157	179	89,8
520	x	615	950000	3654	155	113	28	M22 x 130	930	140	157	179	93,1
540	x	635	986000	3654	150	109	28	M22 x 130	930	140	157	179	96,3
560	x	655	1096000	3915	155	113	30	M22 x 130	930	140	157	179	100
580	x	675	1135000	3915	149	110	30	M22 x 130	930	140	157	179	103
600	x	695	1174000	3915	144	107	30	M22 x 130	930	140	157	179	106

# 3015.1

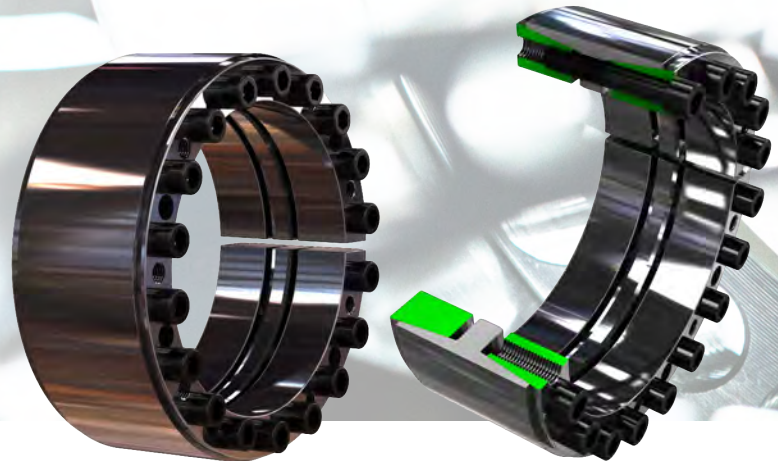
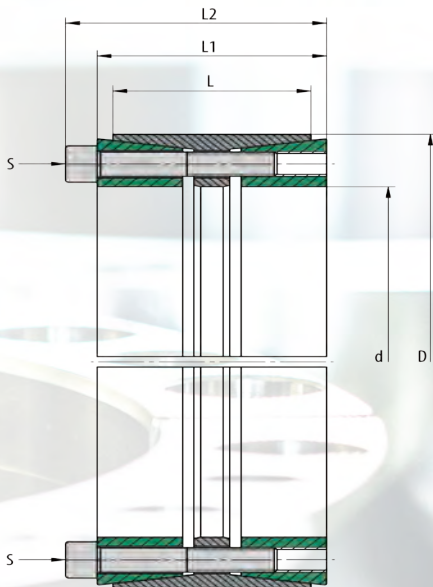

## Used symbols

$d$	[mm]	Shaft diameter	
$D$	[mm]	Hub inside diameter	
$M_t$	[Nm]	Max. transmittable torque	$F_{ax} = 0$
$F_{ax}$	[kN]	Max. transmittable axial force	$M_t = 0$
$p_w$	[N/mm <sup>2</sup> ]	Average pressure on the shaft	
$p_n$	[N/mm <sup>2</sup> ]	Average pressure on the hub	
$L$	[mm]	Length of the sleeve	
$L_1$	[mm]	Width of the locking device without screws	
$L_2$	[mm]	Width of the locking device with screws	
$Z$		Number of clamping screws	
$S$		Size of the clamping screws	
$M_A$	[Nm]	Tightening torque of the clamping screws	

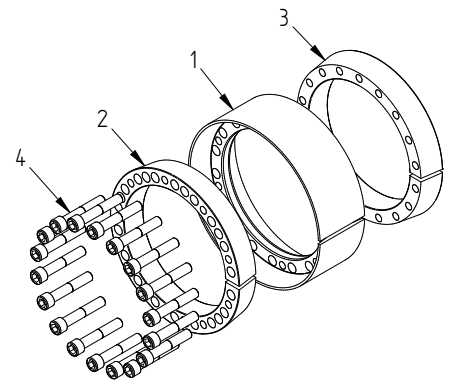

## Recommended tolerances & surfaces

Shaft	h8 / Rz10
Hub	H8 / Rz10

## Bending loads

Bending moment (share)	$M_B \max = 0,4 * M_t$
Bending angle	max. 5°

## More properties

- low axial displacement during assembly
- good self-centering
- low self-locking

Pos.	Designation
1	Sleeve
2	Pressure ring 1
3	Pressure ring 2
4	Screw

Ordering information: TAS 3015.1/d/D (e.g: TAS 3015.1/150/200 ... further sizes on request)

# 3015.1

<b>d</b> mm	<b>x</b>	<b>D</b> mm	<b>M<sub>t</sub></b> Nm	<b>F<sub>ax</sub></b> kN	<b>p<sub>w</sub></b> N/mm <sup>2</sup>	<b>p<sub>N</sub></b> N/mm <sup>2</sup>	<b>Z</b> Pcs.	<b>S</b>	<b>M<sub>A</sub></b> Nm	<b>L</b> mm	<b>L<sub>1</sub></b> mm	<b>L<sub>2</sub></b> mm	<b>Weight</b> kg
70	x	110	4000	116	110	56	8	M10 x 055	49	50	60	70	2,2
80	x	120	5800	146	121	64	10	M10 x 055	49	50	60	70	2,5
90	x	130	7200	160	118	65	11	M10 x 055	49	50	60	70	2,7
100	x	145	8600	173	96	53	10	M12 x 060	69	60	70	82	4,1
110	x	155	9500	173	87	49	10	M12 x 060	69	60	70	82	4,4
120	x	165	11400	191	88	51	11	M12 x 060	69	60	70	82	4,7
130	x	180	15700	243	92	55	14	M12 x 065	69	65	79	91	6,2
140	x	190	18200	260	91	56	15	M12 x 065	69	65	79	91	6,6
150	x	200	19500	260	85	53	15	M12 x 065	69	65	79	91	7,0
160	x	210	22100	277	85	54	16	M12 x 065	69	65	79	91	7,4
170	x	225	29200	344	84	52	15	M14 x 075	108	78	92	106	10,4
180	x	235	30900	344	79	50	15	M14 x 075	108	78	92	106	11,0
190	x	250	34900	367	67	44	16	M14 x 080	108	88	102	116	14,3
200	x	260	45600	456	80	53	18	M14 x 080	108	88	102	116	15,0
220	x	285	52400	476	70	46	15	M16 x 090	168	96	108	124	19,4
240	x	305	76200	635	86	58	20	M16 x 090	168	96	108	124	21,0
260	x	325	82500	635	79	54	20	M16 x 090	168	96	108	124	22,5
280	x	355	117000	839	105	65	15	M20 x 100	369	96	110	130	28,2
300	x	375	134000	895	104	66	16	M20 x 100	369	96	110	130	30,0
320	x	405	179000	1119	97	59	20	M20 x 110	369	124	136	156	47,1
340	x	425	190000	1119	91	56	20	M20 x 110	369	124	136	156	49,7
360	x	455	250000	1389	85	58	20	M22 x 130	495	140	157	179	66,8
380	x	475	263000	1389	81	55	20	M22 x 130	495	140	157	179	70,1
400	x	495	305000	1528	84	58	22	M22 x 130	495	140	157	179	73,4
420	x	515	350000	1667	88	61	24	M22 x 130	495	140	157	179	76,7
440	x	535	366000	1667	84	59	24	M22 x 130	550	140	157	179	79,9
460	x	555	383000	1667	80	57	24	M22 x 130	550	140	157	179	83,2
480	x	575	416000	1736	80	57	25	M22 x 130	550	140	157	179	86,5
500	x	595	434000	1736	77	55	25	M22 x 130	550	140	157	179	89,8
520	x	615	505000	1945	83	60	28	M22 x 130	550	140	157	179	93,1
540	x	635	525000	1945	80	58	28	M22 x 130	550	140	157	179	96,3
560	x	655	583000	2084	82	60	30	M22 x 130	550	140	157	179	99,6
580	x	675	604000	2084	79	58	30	M22 x 130	550	140	157	179	103
600	x	695	625000	2084	77	57	30	M22 x 130	550	140	157	179	106



# 3015 DK

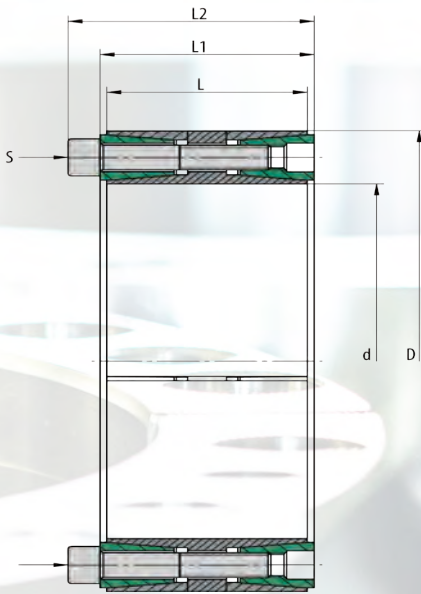

## Used symbols

$d$	[mm]	Shaft diameter	
$D$	[mm]	Hub inside diameter	
$M_t$	[Nm]	Max. transmittable torque	$F_{ax} = 0$
$F_{ax}$	[kN]	Max. transmittable axial force	$M_t = 0$
$p_w$	[N/mm <sup>2</sup> ]	Average pressure on the shaft	
$p_n$	[N/mm <sup>2</sup> ]	Average pressure on the hub	
$L$	[mm]	Length of the sleeve	
$L_1$	[mm]	Width of the locking device without screws	
$L_2$	[mm]	Width of the locking device with screws	
$Z$		Number of clamping screws	
$S$		Size of the clamping screws	
$M_A$	[Nm]	Tightening torque of the clamping screws	

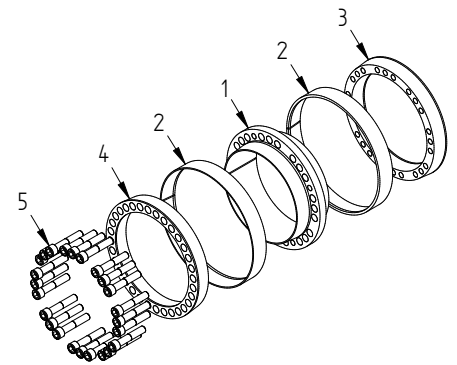

## Recommended tolerances & surfaces

Shaft	h8 / Rz10
Hub	H8 / Rz10

## Bending loads

Bending moment (share)	$M_B \max = 0,25 * M_t$
Bending angle	max. 5°

## More properties

- no axial displacement during assembly
- good self-centering
- low self-locking

Pos.	Designation
1	Sleeve
2	Outer ring
3	Pressure ring 1
4	Pressure ring 2
5	Screw

Ordering information: TAS 3015 DK/d/D (e.g: TAS 3015 DK/150/200 ... further sizes on request)

# 3015 DK

<b>d</b> mm	<b>D</b> mm	<b>M<sub>t</sub></b> Nm	<b>F<sub>ax</sub></b> kN	<b>p<sub>w</sub></b> N/mm <sup>2</sup>	<b>p<sub>N</sub></b> N/mm <sup>2</sup>	<b>Z</b> Pcs.	<b>S</b>	<b>M<sub>A</sub></b> Nm	<b>L</b> mm	<b>L<sub>1</sub></b> mm	<b>L<sub>2</sub></b> mm	<b>Weight</b> kg
100	x 145	15000	300	217	150	10	M12 x 055	145	60	65	77	4,1
110	x 155	16500	300	197	140	10	M12 x 055	145	60	65	77	4,4
120	x 165	21600	360	217	158	12	M12 x 055	145	60	65	77	4,8
130	x 180	29200	450	212	153	15	M12 x 060	145	68	74	86	6,5
140	x 190	37800	540	236	174	18	M12 x 060	145	68	74	86	7,0
150	x 200	40500	540	220	165	18	M12 x 060	145	68	74	86	7,4
160	x 210	48000	600	230	175	20	M12 x 060	145	68	74	86	7,8
170	x 225	61600	725	234	177	18	M14 x 065	230	75	81	95	10,0
180	x 235	65200	725	221	169	18	M14 x 065	230	75	81	95	10,6
190	x 250	76500	805	198	151	20	M14 x 075	230	88	94	108	14,3
200	x 260	96600	966	226	174	24	M14 x 075	230	88	94	108	15,0
220	x 285	109400	995	203	156	18	M16 x 090	355	98	104	120	19,8
240	x 305	159200	1326	248	195	24	M16 x 090	355	98	104	120	21,4
260	x 325	179600	1382	238	191	25	M16 x 090	355	98	104	120	23,0
280	x 355	225200	1608	208	164	24	M18 x 110	485	120	126	144	35,2
300	x 375	251300	1675	202	162	25	M18 x 110	485	120	126	144	37,4
320	x 405	344600	2153	208	164	25	M20 x 120	690	135	142	162	51,3
340	x 425	366100	2153	196	157	25	M20 x 120	690	135	142	162	54,1
360	x 455	483500	2686	198	157	25	M22 x 130	930	158	165	187	75,4
380	x 475	510400	2686	188	150	25	M22 x 130	930	158	165	187	79,0
400	x 495	537200	2686	178	144	25	M22 x 130	930	158	165	187	82,8
420	x 515	676900	3223	204	166	30	M22 x 130	930	158	165	187	86,5
440	x 545	829200	3769	207	167	30	M24 x 150	1200	172	180	204	110
460	x 565	866900	3769	198	161	30	M24 x 150	1200	172	180	204	114
480	x 585	964600	4020	202	166	32	M24 x 150	1200	172	180	204	119
500	x 605	100500	4020	194	160	32	M24 x 150	1200	172	180	204	123
520	x 630	1162900	4473	183	151	30	M27 x 160	1600	190	200	227	148
540	x 650	1207600	4473	176	146	30	M27 x 160	1600	190	200	227	154
560	x 670	1252400	4473	169	142	30	M27 x 160	1600	190	200	227	160
580	x 690	1297100	4473	164	138	30	M27 x 160	1600	190	200	227	165
600	x 710	1431300	4771	169	143	32	M27 x 160	1600	190	200	227	170
620	x 730	1478000	4771	163	139	32	M27 x 160	1600	190	200	227	175

# 3015.1 DK



## Used symbols

$d$	[mm]	Shaft diameter	
$D$	[mm]	Hub inside diameter	
$M_t$	[Nm]	Max. transmittable torque	$F_{ax} = 0$
$F_{ax}$	[kN]	Max. transmittable axial force	$M_t = 0$
$p_w$	[N/mm <sup>2</sup> ]	Average pressure on the shaft	
$p_N$	[N/mm <sup>2</sup> ]	Average pressure on the hub	
$L$	[mm]	Length of the sleeve	
$L_1$	[mm]	Width of the locking device without screws	
$L_2$	[mm]	Width of the locking device with screws	
$Z$		Number of clamping screws	
$S$		Size of the clamping screws	
$M_A$	[Nm]	Tightening torque of the clamping screws	

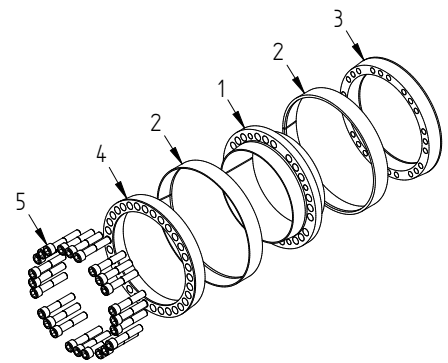

## Recommended tolerances & surfaces

Shaft	h8 / Rz10
Hub	H8 / Rz10

## Bending loads

Bending moment (share)	$M_B \text{ max} = 0,35 * M_t$
Bending angle	max. 5°

## More properties

- no axial displacement during assembly
- good self-centering
- low self-locking

Pos.	Designation
1	Sleeve
2	Outer ring
3	Pressure ring 1
4	Pressure ring 2
5	Screw

Ordering information: TAS 3015.1 DK/d/D (e.g. TAS 3015.1 DK/150/200 ... further sizes on request)



# 3015.1 DK

<b>d</b> mm		<b>D</b> mm	<b>M<sub>t</sub></b> Nm	<b>F<sub>ax</sub></b> kN	<b>p<sub>w</sub></b> N/mm <sup>2</sup>	<b>p<sub>N</sub></b> N/mm <sup>2</sup>	<b>Z</b> Pcs.	<b>S</b>	<b>M<sub>A</sub></b> Nm	<b>L</b> mm	<b>L<sub>1</sub></b> mm	<b>L<sub>2</sub></b> mm	<b>Weight</b> kg
100	x	145	7000	139	101	69	9	M10 x 055	83	60	65	75	4,1
110	x	155	8500	155	102	72	10	M10 x 055	83	60	65	75	4,4
120	x	165	11100	185	112	81	12	M10 x 055	83	60	65	75	4,8
130	x	180	15100	232	109	79	15	M10 x 060	83	68	74	84	6,5
140	x	190	16200	232	101	75	15	M10 x 060	83	68	74	84	7,0
150	x	200	18500	247	101	76	16	M10 x 060	83	68	74	84	7,4
160	x	210	22300	278	106	81	18	M10 x 060	83	68	74	84	7,8
170	x	225	29100	343	111	84	15	M12 x 065	145	75	81	93	10,0
180	x	235	32900	365	111	85	16	M12 x 065	145	75	81	93	10,6
190	x	250	39100	411	101	77	18	M12 x 075	145	88	94	106	14,3
200	x	260	45700	457	107	82	20	M12 x 075	145	88	94	106	15,0
220	x	285	52800	480	98	75	21	M12 x 080	145	98	104	116	19,8
240	x	305	65800	548	102	81	24	M12 x 080	145	98	104	116	21,4
260	x	325	80200	617	106	85	27	M12 x 080	145	98	104	116	23,0
280	x	355	120200	858	111	87	28	M14 x 100	230	120	126	140	35,2
300	x	375	128700	858	104	83	28	M14 x 100	230	120	126	140	37,4
320	x	405	188500	1178	114	90	28	M16 x 110	355	135	142	158	51,3
340	x	425	200300	1178	107	86	28	M16 x 110	355	135	142	158	54,1
360	x	455	220400	1225	90	71	24	M18 x 140	485	158	165	183	75,4
380	x	475	261800	1378	96	77	27	M18 x 140	485	158	165	183	79,0
400	x	495	326600	1633	108	87	32	M18 x 140	485	158	165	183	82,8
420	x	515	342900	1633	103	84	32	M18 x 140	485	158	165	183	86,5
440	x	545	389600	1771	97	78	27	M20 x 140	690	172	180	200	110
460	x	565	407300	1771	93	76	27	M20 x 140	690	172	180	200	114
480	x	585	472200	1968	99	81	30	M20 x 140	690	172	180	200	119
500	x	605	491900	1968	95	78	30	M20 x 140	690	172	180	200	123
520	x	630	545700	2099	86	71	32	M20 x 150	690	190	200	220	148
540	x	650	566700	2099	83	69	32	M20 x 150	690	190	200	220	154
560	x	670	661100	2361	90	75	36	M20 x 150	690	190	200	220	160
580	x	690	684700	2361	86	73	36	M20 x 150	690	190	200	220	165
600	x	710	708300	2361	84	71	36	M20 x 150	690	190	200	220	170
620	x	730	731900	2361	81	69	36	M20 x 150	690	190	200	220	175
640	x	750	755500	2361	78	67	36	M20 x 150	690	190	200	220	180

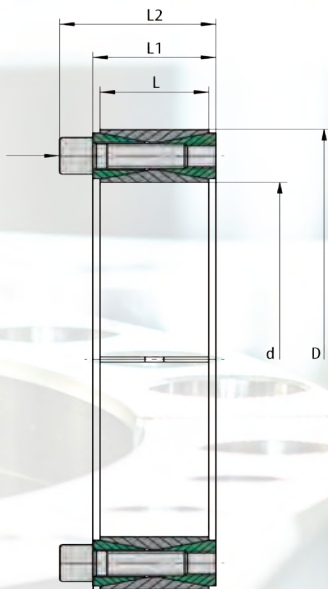

## Used symbols

$d$	[mm]	Shaft diameter
$D$	[mm]	Hub inside diameter
$M_t$	[Nm]	Max. transmittable torque $F_{ax} = 0$
$F_{ax}$	[kN]	Max. transmittable axial force $M_t = 0$
$p_w$	[N/mm <sup>2</sup> ]	Average pressure on the shaft
$p_N$	[N/mm <sup>2</sup> ]	Average pressure on the hub
$L$	[mm]	Length of the sleeve inside and outside
$L_1$	[mm]	Width of the locking device without screws
$L_2$	[mm]	Width of the locking device with screws
$Z$		Number of clamping screws
$S$		Size of the clamping screws
$M_A$	[Nm]	Tightening torque of the clamping screws

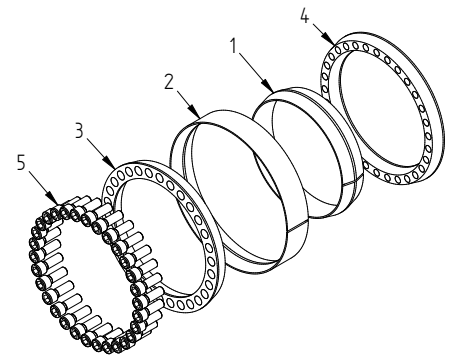

## Recommended tolerances & surfaces

Shaft	from h11 to k11 / Rz10
Hub	from H11 to N11 / Rz10

## Bending loads

Bending moment (share)	depending on hub
Bending angle	max. 2°

## More properties

- no axial displacement during assembly
- no self-centering
- no self-locking

Pos.	Designation
1	Sleeve
2	Outer ring
3	Pressure ring 1
4	Pressure ring 2
5	Screw

Ordering information: TAS 3020/d/D (e.g. TAS 3020/150/200 ... further sizes on request)

<b>d</b> mm	<b>D</b> mm	<b>M<sub>t</sub></b> Nm	<b>F<sub>ax</sub></b> kN	<b>P<sub>w</sub></b> N/mm <sup>2</sup>	<b>P<sub>N</sub></b> N/mm <sup>2</sup>	<b>Z</b> Pcs.	<b>S</b>	<b>M<sub>A</sub></b> Nm	<b>L</b> mm	<b>L<sub>1</sub></b> mm	<b>L<sub>2</sub></b> mm	<b>Weight</b> kg
17	x 47	266	31	291	105	8	M6 x 018	17	17	20	27,5	0,23
18	x 47	282	31	275	105	8	M6 x 018	17	17	20	27,5	0,23
19	x 47	298	31	260	105	8	M6 x 018	17	17	20	27,5	0,23
20	x 47	313	31	247	105	8	M6 x 018	17	17	20	27,5	0,23
22	x 47	345	31	225	105	8	M6 x 018	17	17	20	27,5	0,23
24	x 50	424	35	206	99	9	M6 x 018	17	17	20	27,5	0,26
25	x 50	441	35	198	99	9	M6 x 018	17	17	20	27,5	0,25
28	x 55	549	39	265	135	10	M6 x 018	17	17	20	27,5	0,30
30	x 55	588	39	247	135	10	M6 x 018	17	17	20	27,5	0,29
32	x 60	752	47	232	124	12	M6 x 018	17	17	20	27,5	0,32
35	x 60	822	47	212	124	12	M6 x 018	17	17	20	27,5	0,32
38	x 65	1042	55	244	143	14	M6 x 018	15	17	20	27,5	0,34
40	x 65	1097	55	232	143	14	M6 x 018	17	17	20	27,5	0,34
42	x 75	1740	83	278	156	12	M8 x 022	41	20	24	33,5	0,57
45	x 75	1864	83	259	156	12	M8 x 022	41	20	24	33,5	0,57
48	x 80	1988	83	243	146	12	M8 x 022	41	20	24	33,5	0,60
50	x 80	2071	83	233	146	12	M8 x 022	41	20	24	33,5	0,60
55	x 85	2658	97	265	172	14	M8 x 022	41	20	24	33,5	0,63
60	x 90	2900	97	243	162	14	M8 x 022	41	20	24	33,5	0,69
65	x 95	3587	110	224	153	16	M8 x 022	41	20	24	33,5	0,73
70	x 110	5345	153	286	182	14	M10 x 025	83	24	28	39,5	1,26
75	x 115	5727	153	267	174	14	M10 x 025	83	24	28	39,5	1,33
80	x 120	6108	153	250	167	14	M10 x 025	83	24	28	39,5	1,40
85	x 125	7417	175	236	160	16	M10 x 025	83	24	28	39,5	1,49
90	x 130	7854	175	223	154	16	M10 x 025	83	24	28	39,5	1,53
95	x 135	9326	196	253	178	18	M10 x 025	83	24	28	39,5	1,62
100	x 145	11362	227	273	189	14	M12 x 030	145	26	33	47	2,01
110	x 155	12498	227	248	176	14	M12 x 030	145	26	33	47	2,15
120	x 165	15578	260	243	177	16	M12 x 030	145	26	33	47	2,35
130	x 180	21095	325	214	155	20	M12 x 035	145	34	38	52	3,51
140	x 190	24993	357	219	161	22	M12 x 035	145	34	38	52	3,85
150	x 200	29217	390	223	167	24	M12 x 035	145	34	38	52	4,07
160	x 210	33756	422	226	173	26	M12 x 035	145	34	38	52	4,03
170	x 225	39483	465	217	164	22	M14 x 040	230	38	44	60	5,78
180	x 235	45606	507	223	171	24	M14 x 040	230	38	44	60	6,05
190	x 250	56163	591	204	155	28	M14 x 045	230	46	52	68	8,25
200	x 260	63342	633	207	159	30	M14 x 045	230	46	52	68	8,65
220	x 285	81960	745	206	159	26	M16 x 050	355	50	56	74	11,22
240	x 305	103162	860	218	172	30	M16 x 050	355	50	56	74	12,20
260	x 325	126669	974	228	183	34	M16 x 050	355	50	56	74	13,20
280	x 355	157339	1124	202	159	32	M18 x 060	485	60	66	86,5	19,20
300	x 375	189653	1264	212	169	36	M18 x 060	485	60	66	86,5	20,50
320	x 405	264108	1651	213	168	36	M20 x 070	690	72	78	100,5	29,60



# 3020

<b>d</b> mm		<b>D</b> mm	<b>M<sub>t</sub></b> Nm	<b>F<sub>ax</sub></b> kN	<b>P<sub>w</sub></b> N/mm <sup>2</sup>	<b>P<sub>N</sub></b> N/mm <sup>2</sup>	<b>Z</b> Pcs.	<b>S</b>	<b>M<sub>A</sub></b> Nm	<b>L</b> mm	<b>L<sub>1</sub></b> mm	<b>L<sub>2</sub></b> mm	<b>Weight</b> kg
<b>340</b>	<b>x</b>	<b>425</b>	280614	1651	200	160	36	M20 x 070	690	72	78	100,5	31,1
<b>360</b>	<b>x</b>	<b>455</b>	363061	2017	202	160	36	M22 x 080	930	84	90	116	42,2
<b>380</b>	<b>x</b>	<b>475</b>	383232	2017	191	153	36	M22 x 080	930	84	90	116	44,0
<b>400</b>	<b>x</b>	<b>495</b>	403402	2017	182	147	36	M22 x 080	930	84	90	116	46,0
<b>420</b>	<b>x</b>	<b>515</b>	537000	2559	192	157	40	M22 x 080	930	84	90	116	46,0
<b>440</b>	<b>x</b>	<b>545</b>	658000	2992	188	152	40	M24 x 090	1200	96	102	127	61,2
<b>460</b>	<b>x</b>	<b>565</b>	688000	2992	180	146	40	M24 x 090	1200	96	102	130	63,7
<b>480</b>	<b>x</b>	<b>585</b>	753000	3142	181	148	42	M24 x 090	1200	96	102	130	66,2
<b>500</b>	<b>x</b>	<b>605</b>	822000	3291	182	150	44	M24 x 090	1200	96	102	130	68,7
<b>520</b>	<b>x</b>	<b>630</b>	889000	3422	182	150	45	M24 x 090	1200	96	102	130	74,9
<b>540</b>	<b>x</b>	<b>650</b>	923000	3422	175	145	45	M24 x 090	1200	96	102	127	77,5
<b>560</b>	<b>x</b>	<b>670</b>	1022000	3650	180	151	48	M24 x 090	1200	96	102	130	80,1
<b>580</b>	<b>x</b>	<b>690</b>	1102000	3802	181	152	50	M24 x 090	1200	96	102	130	82,7
<b>600</b>	<b>x</b>	<b>710</b>	1140000	3802	175	148	50	M24 x 090	1200	96	102	130	85,3
<b>620</b>	<b>x</b>	<b>730</b>	1225000	3954	176	150	52	M24 x 090	1200	96	102	130	87,9
<b>640</b>	<b>x</b>	<b>750</b>	1314000	4106	177	151	54	M24 x 090	1200	96	102	130	90,5
<b>660</b>	<b>x</b>	<b>770</b>	1405000	4258	178	153	56	M24 x 090	1200	96	102	130	93,1
<b>680</b>	<b>x</b>	<b>790</b>	1447000	4258	173	149	56	M24 x 090	1200	96	102	130	95,7
<b>700</b>	<b>x</b>	<b>810</b>	1596000	4563	180	156	60	M24 x 090	1200	96	102	130	98,3



**TAS**  
**SCHÄFER**



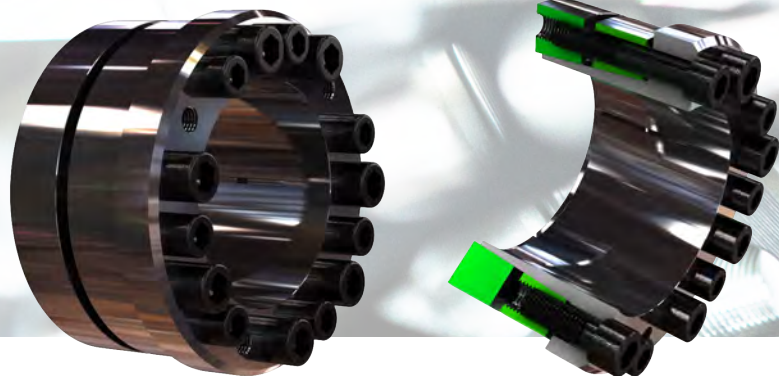
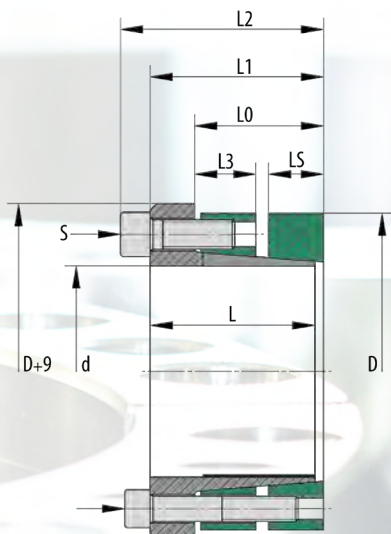

## Used symbols

d [mm]	Shaft diameter
D [mm]	Hub inside diameter
$M_{t1}$ [Nm]	Max. transmittable torque pressure ring 1
$F_{ax1}$ [kN]	Max. transmittable axial force pressure ring 1
$M_{t2}$ [Nm]	Max. transmittable torque pressure ring 2
$F_{ax2}$ [kN]	Max. transmittable axial force pressure ring 2
$M_{t1+2}$ [Nm]	Entire transmittable torque $F_{ax} = 0$
$F_{ax1+2}$ [kN]	Entire transmittable axial force $M_t = 0$
$p_{W1}$ [N/mm <sup>2</sup> ]	Average pressure on the shaft
$p_{N1}$ [N/mm <sup>2</sup> ]	Average pressure on the hub 1
$p_{W2}$ [N/mm <sup>2</sup> ]	Average pressure on the shaft
$p_{N2}$ [N/mm <sup>2</sup> ]	Average pressure on the hub 2
L [mm]	Length of the sleeve
$L_0$ [mm]	Distance pressure ring 2
$L_1$ [mm]	Width of the locking device without screws
$L_2$ [mm]	Width of the locking device with screws
$L_3$ [mm]	Distance pressure ring 1
$L_5$ [mm]	Width of the pressure rings
$Z_1$ & $Z_2$	Number of clamping screws
$S_1$ & $S_2$	Size of the clamping screws
$M_{A1}$ & $M_{A2}$	Tightening torque of the clamping screws

## Empfohlene Toleranzen & Oberflächen

Shaft	h8 / Rz 10
Hub	H8 / Rz 10

## Biegebelastung

Bending moment (share)	$M_{Bmax} = 0,6 * M_t$
Bending angle	max. 5°

## More properties

- no axial displacement during assembly
- very good self-centering
- high self-locking

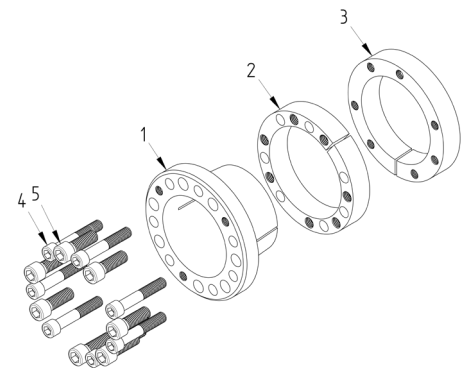

Pos.	Designation
1	Sleeve
2	Pressure ring 1
3	Pressure ring 2
4	Screw $S_2$
5	Screw $S_1$

Ordering information: TAS 4006/d/D (e.g: TAS 4006/030/060 ... further sizes on request)



# 4006

d	D	M <sub>tr</sub>	F <sub>ax1</sub>	M <sub>t2</sub>	F <sub>ax2</sub>	M <sub>tr1+2</sub>	F <sub>ax1+2</sub>	P <sub>W1</sub>	P <sub>M1</sub>	P <sub>W2</sub>	P <sub>M2</sub>	Z <sub>1</sub>	S <sub>1</sub>	M <sub>A1</sub>	Z <sub>2</sub>	S <sub>2</sub>	M <sub>A2</sub>	L	L <sub>0</sub>	L <sub>1</sub>	L <sub>2</sub>	L <sub>3</sub>	L <sub>s</sub>	Weight
mm	mm	Nm	kN	Nm	kN	Nm	kN	N/mm <sup>2</sup>	N/mm <sup>2</sup>	N/mm <sup>2</sup>	N/mm <sup>2</sup>	Pcs.		Nm	Pcs.		Nm	mm	mm	mm	mm	mm	mm	kg
30	x 60	623	42	342	23	965	64	245	124	134	67	4	M8x25	41	4	M6x40	17	45	36	48	56	18	15	0,95
35	x 65	727	42	499	29	1226	70	210	115	144	78	4	M8x25	41	5	M6x40	17	45	36	48	56	18	15	1,00
40	x 70	1039	52	570	29	1609	80	230	133	126	72	5	M8x25	41	5	M6x40	17	45	36	48	56	18	15	1,12
45	x 80	1516	67	1166	52	2682	119	221	126	170	95	4	M10x25	83	5	M8x50	41	54	42	57	67	21	18	1,47
50	x 85	2105	84	1296	52	3401	136	248	148	153	90	5	M10x25	83	5	M8x50	41	54	42	57	67	21	18	1,58
55	x 90	2316	84	1426	52	3741	136	226	140	139	85	5	M10x25	83	5	M8x50	41	54	42	57	67	21	18	1,70
60	x 95	3032	101	1866	62	4898	163	248	159	153	96	6	M10x25	83	6	M8x50	41	54	42	57	67	21	18	1,81
65	x 100	3284	101	2022	62	5306	163	229	151	141	92	6	M10x25	83	6	M8x50	41	54	42	57	67	21	18	1,93
70	x 115	5140	147	3531	101	8672	248	232	143	159	97	6	M12x35	145	6	M10x60	83	70	56	74	86	27	24	3,60
80	x 125	6854	171	4709	118	11562	289	237	154	163	104	7	M12x35	145	7	M10x60	83	70	56	74	86	27	24	4,00
90	x 135	7711	171	5297	118	13008	289	210	142	145	96	7	M12x35	145	7	M10x60	83	70	56	74	86	27	24	4,38
100	x 150	11498	230	8698	174	20195	404	235	159	177	118	7	M14x40	230	7	M12x70	145	78	61	82	96	29	26	6,00
110	x 160	12647	230	9568	174	22215	404	213	149	161	111	7	M14x40	230	7	M12x70	145	78	61	82	96	29	26	6,50
120	x 170	13797	230	10437	174	24235	404	196	140	148	104	7	M14x40	230	7	M12x70	145	78	61	82	96	29	26	6,97
130	x 190	23804	366	17342	267	41146	633	249	170	181	124	8	M16x50	355	8	M14x80	230	90	71	95	111	35	30	11,0
140	x 200	25635	366	18676	267	44311	633	231	162	169	118	8	M16x50	355	8	M14x80	230	90	71	95	111	35	30	11,6
150	x 210	27466	366	20010	267	47476	633	216	154	157	112	8	M16x50	355	8	M14x80	230	90	71	95	111	35	30	13,0
160	x 220	29297	366	21344	267	50641	633	202	147	147	107	8	M16x50	355	8	M14x80	230	90	71	95	111	35	30	12,3
180	x 250	51375	571	32959	366	84334	937	210	151	135	97	8	M20x70	690	8	M16x100	355	114	92	122	142	45	40	22,1
200	x 270	71355	714	45776	458	117131	1171	237	175	152	112	10	M20x70	690	10	M16x100	355	114	92	122	142	45	40	24,3
220	x 290	78490	714	50354	458	128844	1171	215	163	138	105	10	M20x70	690	10	M16x100	355	114	92	122	142	45	40	26,3
240	x 310	102751	856	65918	549	168669	1406	237	183	152	118	12	M20x70	690	12	M16x100	355	114	92	122	142	45	40	28,6
260	x 330	109740	844	70402	542	180143	1386	215	170	138	109	12	M20x70	690	12	M16x110	355	114	92	122	142	45	40	30,6
280	x 365	143639	1026	98485	703	242124	1729	216	166	148	114	10	M24x80	1200	10	M20x120	690	135	108	144	168	50	45	46,5
300	x 385	153899	1026	105520	703	259419	1729	202	157	138	108	10	M24x80	1200	10	M20x120	690	135	108	144	168	50	45	49,3
320	x 405	196991	1231	135065	844	332056	2075	227	179	155	123	12	M24x80	1200	12	M20x120	690	135	108	144	168	50	45	52
340	x 425	244186	1436	167425	985	411611	2421	249	199	171	137	14	M24x80	1200	14	M20x120	690	135	108	144	168	50	45	54
360	x 445	258550	1436	177273	985	435823	2421	235	190	161	130	14	M24x80	1200	14	M20x120	690	135	108	144	168	50	45	57
380	x 465	311902	1642	213853	1126	525755	2767	255	208	175	143	16	M24x80	1200	16	M20x120	690	135	108	144	168	50	45	60
400	x 485	328318	1642	225109	1126	553426	2767	242	200	166	137	16	M24x80	1200	16	M20x120	690	135	108	144	168	50	45	64
420	x 505	344734	1642	236364	1126	581098	2767	230	192	158	131	16	M24x80	1200	16	M20x120	690	135	108	144	168	50	45	66
440	x 525	361150	1642	247619	1126	608769	2767	168	141	115	96	16	M24x80	1200	16	M20x140	690	167	147	178	202	80	59	70
460	x 545	377565	1642	258875	1126	636440	2767	160	135	110	93	16	M24x80	1200	16	M20x140	690	167	147	178	202	80	59	73
480	x 565	393981	1642	270130	1126	664112	2767	154	131	105	90	16	M24x80	1200	16	M20x140	690	167	147	178	202	80	59	76
500	x 585	461697	1847	316559	1266	778256	3113	166	142	114	97	18	M24x80	1200	18	M20x140	690	167	147	178	202	80	59	79

# 4006

d	D	M <sub>t1</sub>	F <sub>ax1</sub>	M <sub>t2</sub>	F <sub>ax2</sub>	M <sub>t1+2</sub>	F <sub>ax1+2</sub>	P <sub>W1</sub>	P <sub>N1</sub>	P <sub>W2</sub>	P <sub>N2</sub>	Z <sub>1</sub>	S <sub>1</sub>	M <sub>A1</sub>	Z <sub>2</sub>	S <sub>2</sub>	M <sub>A2</sub>	L	L <sub>0</sub>	L <sub>1</sub>	L <sub>2</sub>	L <sub>3</sub>	L <sub>s</sub>	Weight
mm	mm	Nm	kN	Nm	kN	Nm	kN	N/mm <sup>2</sup>	N/mm <sup>2</sup>	N/mm <sup>2</sup>	N/mm <sup>2</sup>	Pcs.		Nm	Pcs.		Nm	mm	mm	mm	mm	mm	mm	kg
520	x 605	480165	1847	329221	1266	809386	3113	160	137	109	94	18	M24x80	1200	18	M20x140	690	167	147	178	202	80	59	82
540	x 625	498633	1847	341884	1266	840516	3113	154	133	105	91	18	M24x80	1200	18	M20x140	690	167	147	178	202	80	59	85
560	x 645	517101	1847	354546	1266	871647	3113	148	129	102	88	18	M24x80	1200	18	M20x140	690	167	147	178	202	80	59	88
580	x 665	595076	2052	408009	1407	1003085	3459	159	139	109	95	20	M24x80	1200	20	M20x140	690	167	147	178	202	80	59	91
600	x 685	615596	2052	422079	1407	1037675	3459	154	135	105	92	20	M24x80	1200	20	M20x140	690	167	147	178	202	80	59	94
620	x 705	636116	2052	436148	1407	1072264	3459	149	131	102	90	20	M24x80	1200	20	M20x140	690	167	147	178	202	80	59	98



**Comprehensive  
technical advice  
with decades  
of know-how**

**TAS**  
**SCHÄFER**



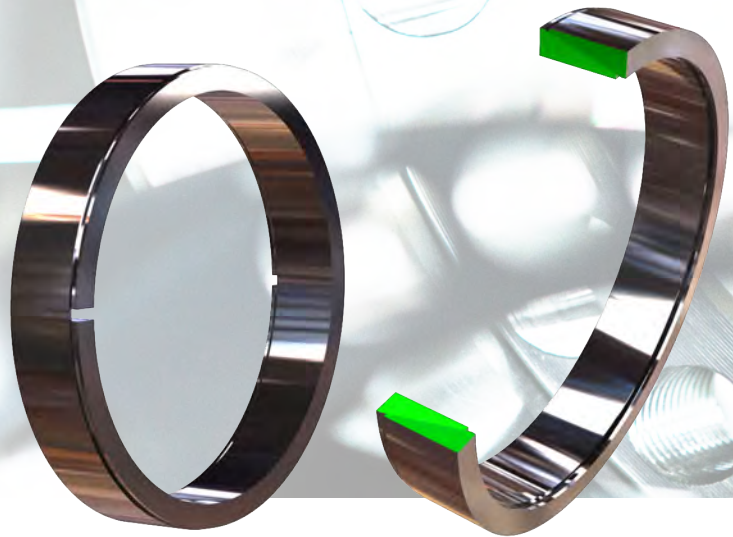
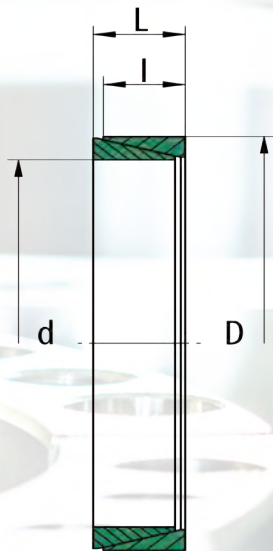

## Used symbols

d	[mm]	Shaft diameter
D	[mm]	Hub inside diameter
L	[mm]	Length of the locking device
l	[mm]	Width of inner ring and outer ring
$A_t$	[mm <sup>2</sup> ]	Contact surface of the shaft
$F_o$	[N]	Pretension to eliminate tolerances (for unslitted version)
$F_A$	[N]	Clamping force required to apply pressure of $p = 100 \text{ N/mm}^2$
T	[Nm]	Max. transmittable torque (at $p = 100 \text{ N/mm}^2$ ) $F_{ax} = 0$
$F_{ax}$	[N]	Max. transmittable axial force (at $p = 100 \text{ N/mm}^2$ ) $T = 0$
x	[mm]	Distance between clamping flange and hub in relation to the number of clamping elements
$d_1$	[mm]	inner diameter spacer bushing
$D_1$	[mm]	outer diameter spacer bushing

## More properties

- axial displacement during assembly
- good self-centering
- no self-locking

## Recommended tolerances & surfaces

Shaft	< d 38mm h6 / > d 40mm h8 / Rz10
Hub	< d 38mm H7 / > d 40mm H8 / Rz10

## Bending loads

Bending moment (share)  
Depending on hub design and number of clamping elements

Ordering information: TAS 8006/d/D (z.B: TAS 8006/150/200 ...further sizes on request)  
TAS 8006/d/D slotted (e.g: TAS 8006/150/200 slotted ... further sizes on request)

# 8006

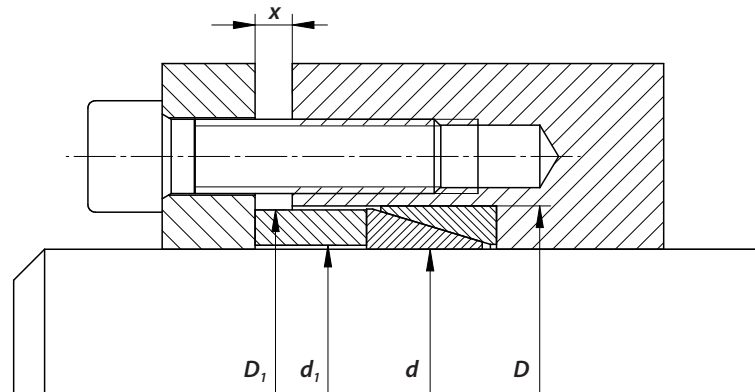
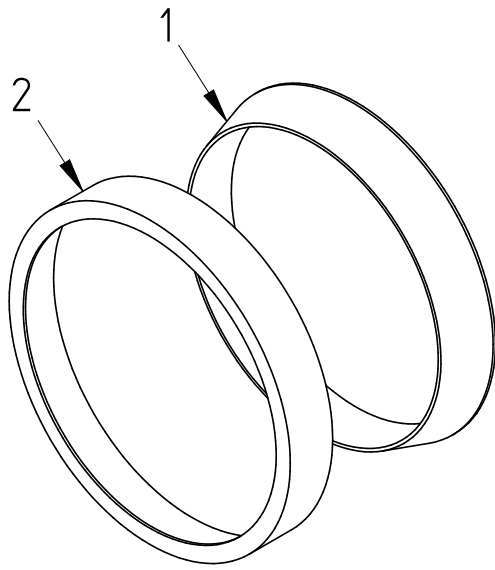

When arranging several elements, ensure that there is no mutual inhibition.



Pos.	Designation
1	Inner ring
2	Outer ring

d	D	L	I	A <sub>t</sub>	F <sub>o</sub>	F <sub>A</sub>	T	F <sub>ax</sub>	x				Weight	d <sub>1</sub>	D <sub>1</sub>
									1	2	3	4			
mm	mm	mm	mm	mm <sup>2</sup>	N	N	Nm	N	Locking elements mm				kg	mm	mm
6	x 9	4,5	3,7	69	-	3240	2,16	720	2	2	3	3	0,00118	6,1	8,9
7	x 10	4,5	3,7	80	-	3780	2,94	840	2	2	3	3	0,00136	7,1	9,9
8	x 11	4,5	3,7	90	-	4300	3,84	960	2	2	3	3	0,00151	8,1	10,9
9	x 12	4,5	3,7	105	7600	5700	5,7	1270	2	2	3	3	0,00166	9,1	11,9
10	x 13	4,5	3,7	116	6950	6300	7	1400	2	2	3	3	0,00182	10,1	12,9
12	x 15	4,5	3,7	139	6950	7500	10	1670	2	2	3	3	0,00214	12,1	14,9
13	x 16	4,5	3,7	151	6450	8150	11,8	1810	2	2	3	3	0,00226	13,1	15,9
14	x 18	6,3	5,3	233	11200	12600	19,6	2800	3	3	4	5	0,00487	14,1	17,9
15	x 19	6,3	5,3	250	10750	13500	22,5	3000	3	3	4	5	0,00526	15,1	18,9
16	x 20	6,3	5,3	266	10100	14400	25,5	3190	3	3	4	5	0,00545	16,1	19,9
17	x 21	6,3	5,3	283	9550	15300	28,9	3400	3	3	4	5	0,0058	17,1	20,9
18	x 22	6,3	5,3	300	9100	16200	32,4	3600	3	3	4	5	0,00612	18,1	21,9
19	x 24	6,3	5,3	316	12600	17100	36	3790	3	3	4	5	0,00782	19,2	23,8
20	x 25	6,3	5,3	333	12050	18000	40	4000	3	3	4	5	0,00817	20,2	24,8
22	x 26	6,3	5,3	366	9050	19800	48	4400	3	3	4	5	0,00724	22,2	25,8
24	x 28	6,3	5,3	400	8350	21600	58	4800	3	3	4	5	0,00792	24,2	27,8
25	x 30	6,3	5,3	416	9900	22500	62	5000	3	3	4	5	0,0101	25,2	29,8
28	x 32	6,3	5,3	466	7400	25200	78	5600	3	3	4	5	0,00918	28,2	31,8
30	x 35	6,3	5,3	499	8500	27000	90	6000	3	3	4	5	0,012	30,2	34,8
32	x 36	6,3	5,3	533	7850	28800	102	6400	3	3	4	5	0,01	32,2	35,8
35	x 40	7	6	659	10100	35600	138	7900	3	3	4	5	0,017	35,2	39,8
36	x 42	7	6	678	11600	36600	147	8200	3	3	4	5	0,02	36,2	41,8
38	x 44	7	6	716	11000	38700	163	8600	3	3	4	5	0,021	38,2	43,8
40	x 45	8	6,6	829	13800	45000	199	9950	3	4	5	6	0,023	40,2	44,8
42	x 48	8	6,6	870	15600	47000	219	10400	3	4	5	6	0,028	42,2	47,8

# 8006

d	D	L	l	A <sub>t</sub>	F <sub>o</sub>	F <sub>A</sub>	T	F <sub>ax</sub>	x				Weight	d <sub>1</sub>	D <sub>1</sub>
									1	2	3	4			
mm	mm	mm	mm	mm <sup>2</sup>	N	N	Nm	N	Locking elements mm				kg	mm	mm
45	x 52	10	8,6	1215	28200	66000	328	14600	3	4	5	6	0,042	45,2	51,8
48	x 55	10	8,6	1296	24600	70000	373	15600	3	4	5	6	0,045	48,2	54,8
50	x 57	10	8,6	1350	23500	73000	405	16200	3	4	5	6	0,047	50,2	56,8
55	x 62	10	8,6	1485	21800	80000	490	17800	3	4	5	6	0,05	55,2	61,8
56	x 64	12	10,4	1829	29400	99000	615	22000	3	4	5	7	0,067	56,2	63,8
60	x 68	12	10,4	1959	27400	106000	705	23500	3	4	5	7	0,072	60,2	67,8
63	x 71	12	10,4	2057	26300	111000	780	24800	3	4	5	7	0,077	63,2	70,8
65	x 73	12	10,4	2123	25400	115000	830	25600	3	4	5	7	0,079	65,2	72,8
70	x 79	14	12,2	2682	31000	145000	1120	32000	3	5	6	7	0,111	70,3	78,7
71	x 80	14	12,2	2720	31000	147000	1160	32600	3	5	6	7	0,113	71,3	79,7
75	x 84	14	12,2	2873	34600	155000	1290	34400	3	5	6	7	0,12	75,3	83,7
80	x 91	17	15	3768	48000	203000	1810	45000	4	5	6	8	0,188	80,3	90,7
85	x 96	17	15	4004	45600	216000	2040	48000	4	5	6	8	0,2	85,3	95,7
90	x 101	17	15	4239	43400	229000	2290	51000	4	5	6	8	0,216	90,3	100,7
95	x 106	17	15	4475	41200	242000	2550	54000	4	5	6	8	0,224	95,3	105,7
100	x 114	21	18,7	5872	60700	317000	3520	70000	4	6	7	9	0,38	100,3	113,7
110	x 124	21	18,7	6459	66000	349000	4250	77000	4	6	7	9	0,41	110,3	123,7
120	x 134	21	18,7	7046	60200	380000	5050	84000	4	6	7	9	0,452	120,3	133,7
130	x 148	28	25,3	10328	96200	558000	8050	124000	5	7	9	11	0,847	130,3	147,6
140	x 158	28	25,3	11122	89000	600000	9350	134000	5	7	9	11	0,91	140,3	157,6
150	x 168	28	25,3	11916	84500	643000	10700	143000	5	7	9	11	0,967	150,4	167,6
160	x 178	28	25,3	12711	78500	686000	12200	152500	5	7	9	11	1,023	160,4	177,6
170	x 191	33	30	16014	117500	865000	16300	192000	6	8	10	12	1,5	170,4	190,5
180	x 201	33	30	16956	111200	916000	18300	204000	6	8	10	12	1,58	180,5	200,5
190	x 211	33	30	17898	105000	966000	20400	214000	6	8	10	12	1,68	190,5	210,5
200	x 224	38	34,8	21854	134000	1180000	26200	262000	6	8	11	13	2,32	200,6	223,4
210	x 234	38	34,8	22947	127000	1239000	28900	275000	6	8	11	13	2,45	210,6	233,4
220	x 244	38	34,8	24040	122000	1298000	31700	288000	6	8	11	13	2,49	220,6	243,4
230	x 257	43	39,5	28527	165000	1540000	39400	342000	6	9	12	14	3,38	230,6	256,4
240	x 267	43	39,5	29767	157500	1610000	43000	358000	6	9	12	14	3,52	240,6	266,4
250	x 280	48	44	34700	190000	1870000	52000	415000	7	10	13	16	4,68	250,8	279,2
260	x 290	48	44	36100	182000	1950000	56500	435000	7	10	13	16	4,82	260,8	289,2
270	x 300	48	44	37500	177000	2030000	61000	450000	7	10	13	16	4,94	270,8	299,2
280	x 313	53	49	43100	206000	2330000	72500	520000	7	10	14	17	6,27	280,8	312,2
290	x 323	53	49	44600	222000	2410000	77500	535000	7	11	14	17	6,5	290,8	332,2
300	x 333	53	49	46200	214000	2490000	83000	555000	7	11	14	17	6,74	300,8	322,2
320	x 360	65	59	59300	292000	3200000	114000	710000	10	15	20	25	10,9	321	359
340	x 380	65	59	63000	272000	3400000	128500	755000	10	15	20	25	11,5	341	379
360	x 400	65	59	66700	258000	3600000	144000	800000	10	15	20	25	12,2	361	399
380	x 420	65	59	70400	269000	3800000	160500	845000	10	15	20	25	12,8	381	419
400	x 440	65	59	74200	256000	4000000	178000	890000	10	15	20	25	13,5	401	439
420	x 460	65	59	77800	244000	4200000	196000	935000	10	15	20	25	14,1	421	459
440	x 480	65	59	81500	234000	4400000	215000	980000	10	15	20	25	14,7	441	479
460	x 500	65	59	85300	224000	4600000	235000	1020000	10	15	20	25	15,4	461	499
480	x 520	65	59	89000	239000	4800000	256000	1070000	10	15	20	25	16	481	519
500	x 540	65	59	92700	229000	5000000	278000	1110000	10	15	20	25	16,6	501	539





203016

Mahr  
COORDINATE  
MEASURING  
MACHINE  
Crystall

WARNING

**TAS**  
SCHÄFER



# TAS 110

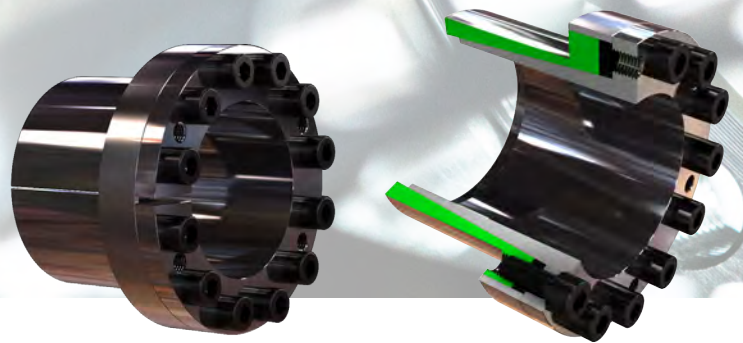
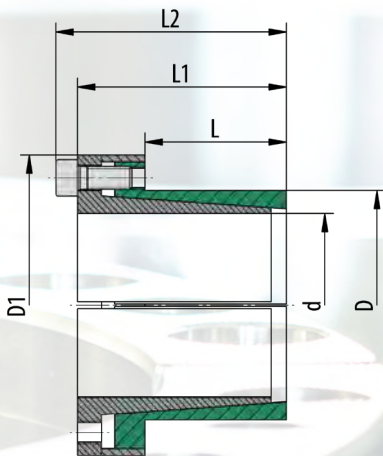

## Used symbols

d [mm]	Shaft diameter	
D [mm]	Hub inside diameter	
$D_1$ [mm]	Diameter of the bush	
$M_t$ [Nm]	Max. transmittable torque	$F_{ax} = 0$
$F_{ax}$ [kN]	Max. transmittable axial force	$M_t = 0$
$p_w$ [N/mm <sup>2</sup> ]	Average pressure on the shaft	
$p_N$ [N/mm <sup>2</sup> ]	Average pressure on the hub	
L [mm]	Length clamping surface of the hub	
$L_1$ [mm]	Width of the locking device without screws	
$L_2$ [mm]	Width of the locking device with screws	
Z	Number of clamping screws	
S	Size of the clamping screws	
$M_A$ [Nm]	Tightening torque of the clamping screws	

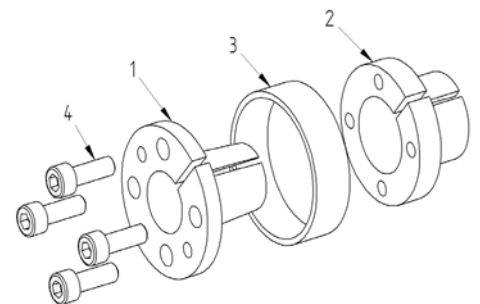

## Recommended tolerances & surfaces

Shaft	h8 / Rz10
Hub	H8 / Rz10

## Bending loads

Bending moment (share)	MB max = 0,25 * $M_t$
Bending angle	max. 3°

## More properties

- no axial displacement during assembly
- good self-centering
- high self-locking

Pos.	Designation
1	Sleeve
2	Sleeve
3	Outer ring
4	Screw

Ordering information: TAS 110 /d/D (e.g. TAS 110/10/16 ...  
further sizes on request)

# TAS 110

<b>d</b> mm	<b>D</b> mm	<b>D<sub>1</sub></b> mm	<b>M<sub>t</sub></b> Nm	<b>F<sub>ax</sub></b> kN	<b>P<sub>w</sub></b> N/mm <sup>2</sup>	<b>P<sub>N</sub></b> N/mm <sup>2</sup>	<b>Z</b> Pcs.	<b>S</b>	<b>M<sub>A</sub></b> Nm	<b>L</b> mm	<b>L<sub>1</sub></b> mm	<b>L<sub>2</sub></b> mm	<b>Weight</b> kg	
6	x	14	25	11	3,8	158	68	4	M 3 x 10	2,6	10	21,5	24,5	0,04
8	x	15	27	26	6,5	185	98	3	M 4 x 10	5,6	11,5	25	29	0,06
9	x	16	28	37	8	174	98	4	M 4 x 10	5,6	14	26	30	0,06
9,525	x	16	29	39	8	165	98	4	M 4 x 10	5,6	14	26	30	0,06
10	x	16	29	42	8	158	98	4	M 4 x 10	5,6	14	26	30	0,06
11	x	18	32	50	9	167	100	4	M 4 x 10	5,6	13,5	26	30	0,07
12	x	18	32	55	9	151	100	4	M 4 x 10	5,6	13,5	26	30	0,07
14	x	23	38	100	14	197	120	6	M 4 x 10	5,6	14	26	30	0,11
15	x	24	44	145	19	209	130	4	M 6 x 18	15	16	36	42	0,22
16	x	24	44	155	19	196	130	4	M 6 x 18	15	16	36	42	0,22
17	x	25	45	162	19	185	125	4	M 6 x 18	15	16	36	42	0,22
17	x	26	47	180	23	185	122	4	M 6 x 18	17	18	38	44	0,23
18	x	26	47	200	23	177	120	4	M 6 x 18	17	18	38	44	0,23
19	x	27	48	210	23	170	120	4	M 6 x 18	17	18	38	44	0,24
20	x	28	49	220	23	166	120	4	M 6 x 18	17	18	38	44	0,25
22	x	32	54	250	23	104	70	4	M 6 x 18	17	25	45	51	0,33
24	x	34	56	270	23	99	70	4	M 6 x 18	17	25	45	51	0,35
25	x	34	56	280	23	95	70	4	M 6 x 18	17	25	45	51	0,34
28	x	39	61	480	34	127	90	6	M 6 x 18	17	25	45	51	0,42
30	x	41	62	510	34	116	84	6	M 6 x 18	17	25	45	51	0,43
32	x	43	65	730	46	154	115	8	M 6 x 18	17	25	45	51	0,50
35	x	47	69	800	46	111	81	8	M 6 x 18	17	30	50	56	0,55
38	x	50	72	860	46	102	76	8	M 6 x 18	17	30	50	56	0,60
40	x	53	75	900	46	96	72	8	M 6 x 18	17	30	50	56	0,65
42	x	55	78	1800	84	165	125	8	M 8 x 22	41	32	57	65	0,85
45	x	59	85	1900	84	118	89	8	M 8 x 22	41	40	65	73	1,10
48	x	62	87	2000	84	99	75	8	M 8 x 22	41	45	70	78	1,10
50	x	65	92	2600	105	118	90	10	M 8 x 22	41	45	70	78	1,30
55	x	71	98	2900	105	94	70	10	M 8 x 22	41	50	75	83	1,50
60	x	77	104	3100	105	90	70	10	M 8 x 22	41	50	75	83	1,70
65	x	84	111	3400	105	79	60	10	M 8 x 22	41	50	75	83	2,00
70	x	90	119	5800	170	103	80	10	M 10 x 25	83	60	91	101	2,80
75	x	95	126	6200	170	91	70	10	M 10 x 25	83	60	91	101	3,00
80	x	100	131	8000	200	100	80	12	M 10 x 25	83	65	96	106	3,30
85	x	106	137	8500	200	89	70	12	M 10 x 25	83	65	96	106	3,60
90	x	112	143	11200	250	112	90	15	M 10 x 25	83	65	96	106	3,90
95	x	120	153	11800	250	102	80	15	M 10 x 25	83	65	96	106	4,60
100	x	125	162	14600	300	120	95	12	M 12 x 30	145	65	102	114	5,50
110	x	140	180	16000	300	77	61	12	M 12 x 30	145	90	128	140	8,30
120	x	155	198	17400	300	72	55	12	M 12 x 30	145	90	128	140	10,30
130	x	165	208	25000	389	87	69	16	M 12 x 30	145	90	128	140	10,60



# TAS 130

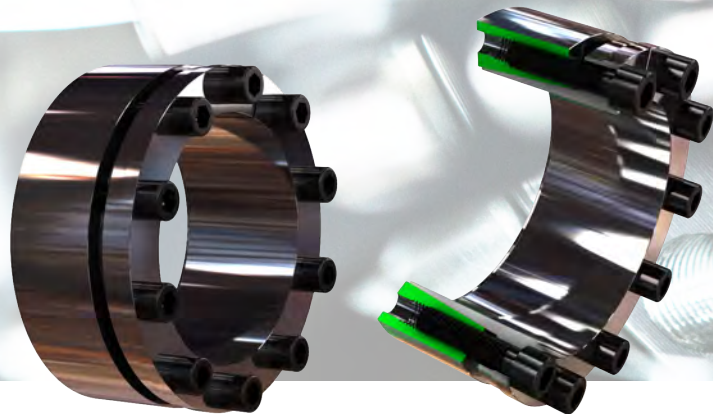
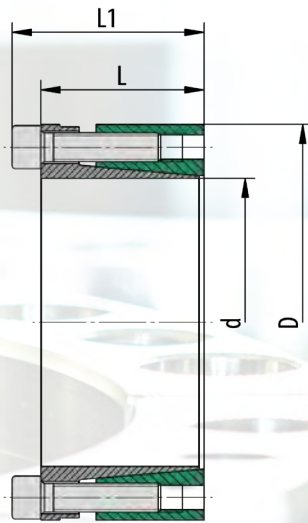

## Used symbols

$d$	[mm]	Shaft diameter
$D$	[mm]	Hub inside diameter
$M_t$	[Nm]	Max. transmittable torque $F_{ax} = 0$
$F_{ax}$	[kN]	Max. transmittable axial force $M_t = 0$
$p_w$	[N/mm <sup>2</sup> ]	Average pressure on the shaft
$p_N$	[N/mm <sup>2</sup> ]	Average pressure on the hub
$L$	[mm]	Width of the locking device without screws
$L_1$	[mm]	Width of the locking device with screws
$Z$		Number of clamping screws
$S$		Size of the clamping screws
$M_A$	[Nm]	Tightening torque of the clamping screws

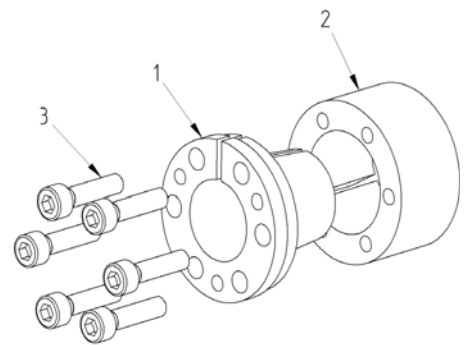

## Recommended tolerances & surfaces

Shaft	h8 / Rz10
Hub	H8 / Rz10

Pos.	Designation
1	Sleeve
2	Pressure ring
3	Screw

## Bending loads

Bending moment (share)	MB max = 0,35 * Mt
Bending angle	max. 5°

## More properties

- low axial displacement during assembly
- good self-centering
- high self-locking

Ordering information: TAS 130 /d/D (e.g: TAS 130/20/47 ...  
further sizes on request)

# TAS 130

<i>d</i> mm		<i>D</i> mm	<i>M<sub>t</sub></i> Nm	<i>F<sub>ax</sub></i> kN	<i>P<sub>w</sub></i> N/mm <sup>2</sup>	<i>P<sub>N</sub></i> N/mm <sup>2</sup>	<i>Z</i> Pcs.	<i>S</i>	<i>M<sub>A</sub></i> Nm	<i>L</i> mm	<i>L<sub>1</sub></i> mm	<i>Weight</i> kg
20	x	47	530	52	264	110	6	M 6 x 25	17	42	48	0,41
22	x	47	580	52	239	110	6	M 6 x 25	17	42	48	0,38
24	x	50	630	52	217	100	6	M 6 x 25	17	42	48	0,42
25	x	50	660	52	208	100	6	M 6 x 25	17	42	48	0,41
28	x	55	740	52	194	100	6	M 6 x 25	17	42	48	0,50
30	x	55	790	70	182	100	6	M 6 x 25	17	42	48	0,47
32	x	60	1150	70	226	120	8	M 6 x 25	17	42	48	0,56
35	x	60	1300	70	209	120	8	M 6 x 25	17	42	48	0,53
38	x	65	1300	70	188	110	8	M 6 x 25	17	42	48	0,62
40	x	65	1400	70	180	110	8	M 6 x 25	17	42	48	0,57
42	x	75	2000	100	209	120	6	M 8 x 30	41	51	59	1,01
45	x	75	2200	100	197	120	6	M 8 x 30	41	51	59	0,98
48	x	80	3200	130	249	150	8	M 8 x 30	41	51	59	1,09
50	x	80	3300	130	239	150	8	M 8 x 30	41	51	59	1,07
55	x	85	3600	130	215	140	8	M 8 x 30	41	51	59	1,15
60	x	90	3900	130	194	130	8	M 8 x 30	41	51	59	1,23
65	x	95	4300	130	177	120	8	M 8 x 30	41	51	59	1,32
70	x	110	7500	210	203	130	8	M 10 x 30	83	61	71	2,18
75	x	115	8000	210	196	130	8	M 10 x 30	83	61	71	2,30
80	x	120	8500	210	179	120	8	M 10 x 30	83	61	71	2,44
85	x	125	11400	270	217	150	10	M 10 x 30	83	61	71	2,55
90	x	130	12000	270	201	140	10	M 10 x 30	83	61	71	2,67
95	x	135	12600	280	190	135	10	M 10 x 30	83	61	71	2,80
100	x	145	15000	300	185	130	8	M 12 x 35	145	68	80	3,90
110	x	155	16500	300	167	120	8	M 12 x 35	145	68	80	4,20
120	x	165	22500	370	190	140	10	M 12 x 35	145	68	80	4,50
130	x	180	29000	450	206	150	12	M 12 x 35	145	68	80	5,50
140	x	190	32000	460	175	130	10	M 14 x 40	210	76	90	6,60
150	x	200	41000	550	198	150	12	M 14 x 40	210	76	90	6,90
160	x	210	44000	550	183	140	12	M 14 x 40	210	76	90	7,40
170	x	225	54500	640	210	160	14	M 14 x 40	210	76	90	8,60
180	x	235	57500	640	190	150	14	M 14 x 40	210	76	90	9,10
190	x	250	65000	689	191	146	15	M 14 x 40	210	76	90	10,60
200	x	260	68000	689	183	141	15	M 14 x 40	210	76	90	11,20
220	x	285	82000	747	141	109	12	M 16 x 50	325	98	114	17,70

# TAS 131

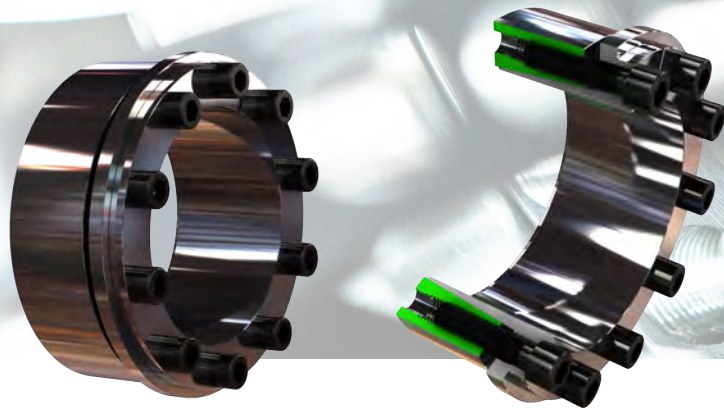
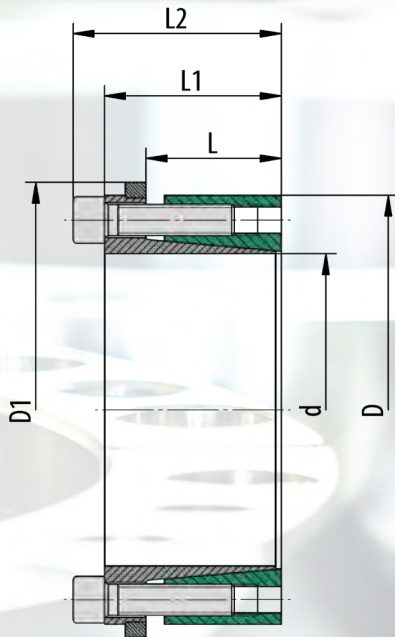

## Used symbols

$d$	[mm]	Shaft diameter	
$D$	[mm]	Hub inside diameter	
$D_1$	[mm]	Diameter of the bush	
$M_t$	[Nm]	Max. transmittable torque	$F_{ax} = 0$
$F_{ax}$	[kN]	Max. transmittable axial force	$M_t = 0$
$p_w$	[N/mm <sup>2</sup> ]	Average pressure on the shaft	
$p_N$	[N/mm <sup>2</sup> ]	Average pressure on the hub	
$L$	[mm]	Distance of the pressure ring	
$L_1$	[mm]	Width of the locking device without screws	
$L_2$	[mm]	Width of the locking device with screws	
$Z$		Number of clamping screws	
$S$		Size of the clamping screws	
$M_A$	[Nm]	Tightening torque of the clamping screws	

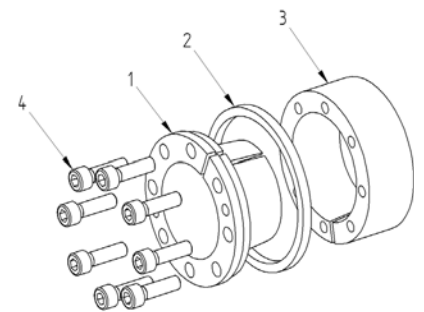

## Recommended tolerances & surfaces

Shaft	h8 / Rz10
Hub	H8 / Rz10

## Bending loads

Bending moment (share)	MB max = 0,35 * Mt
Bending angle	max. 5°

## More properties

- no axial displacement during assembly
- good self-centering
- high self-locking

Pos.	Designation
1	Sleeve
2	Distance ring
3	Pressure ring
4	Screw

Ordering information: TAS 131 /d/D (e.g. TAS 131/20/47 ...  
further sizes on request)



# TAS 131

<b>d</b> mm		<b>D</b> mm	<b>D<sub>1</sub></b> mm	<b>M<sub>t</sub></b> Nm	<b>F<sub>ax</sub></b> kN	<b>p<sub>w</sub></b> N/mm <sup>2</sup>	<b>p<sub>N</sub></b> N/mm <sup>2</sup>	<b>Z</b> Pcs.	<b>S</b>	<b>M<sub>A</sub></b> Nm	<b>L</b> mm	<b>L<sub>1</sub></b> mm	<b>L<sub>2</sub></b> mm	<b>Weight</b> kg
20	x	47	53	320	33	170	70	6	M 6 x 25	17	31	42	48	0,42
22	x	47	53	360	33	153	70	6	M 6 x 25	17	31	42	48	0,39
24	x	50	56	390	33	144	70	6	M 6 x 25	17	31	42	48	0,43
25	x	50	56	400	33	138	70	6	M 6 x 25	17	31	42	48	0,42
28	x	55	61	450	33	120	60	6	M 6 x 25	17	31	42	48	0,51
30	x	55	61	490	33	112	60	6	M 6 x 25	17	31	42	48	0,48
32	x	60	66	690	43	136	70	8	M 6 x 25	17	31	42	48	0,57
35	x	60	66	750	43	124	70	8	M 6 x 25	17	31	42	48	0,54
38	x	65	71	820	43	120	70	8	M 6 x 25	17	31	42	48	0,63
40	x	65	71	860	43	113	70	8	M 6 x 25	17	31	42	48	0,58
42	x	75	81	1300	60	126	70	6	M 8 x 30	41	35	51	59	1,02
45	x	75	81	1400	60	118	70	6	M 8 x 30	41	35	51	59	0,99
48	x	80	86	1900	80	150	90	8	M 8 x 30	41	35	51	59	1,10
50	x	80	86	2000	80	144	90	8	M 8 x 30	41	35	51	59	1,08
55	x	85	91	2200	80	136	90	8	M 8 x 30	41	35	51	59	1,16
60	x	90	96	2400	80	120	80	8	M 8 x 30	41	35	51	59	1,24
65	x	95	101	2600	80	105	70	8	M 8 x 30	41	35	51	59	1,33
70	x	110	119	4600	130	126	80	8	M 10 x 30	83	46	61	71	2,29
75	x	115	124	5000	130	120	80	8	M 10 x 30	83	46	61	71	2,41
80	x	120	129	5200	130	107	70	8	M 10 x 30	83	46	61	71	2,56
85	x	125	134	7000	170	132	90	10	M 10 x 30	83	46	61	71	2,67
90	x	130	139	7400	170	117	80	10	M 10 x 30	83	46	61	71	2,80
95	x	135	144	7800	170	114	80	10	M 10 x 30	83	46	61	71	2,93
100	x	145	155	9800	190	115	80	8	M 12 x 35	145	52	68	80	4,10
110	x	155	165	10700	190	101	70	8	M 12 x 35	145	52	68	80	4,40
120	x	165	175	14600	240	122	90	10	M 12 x 35	145	52	68	80	4,72
130	x	180	188	19000	300	137	100	12	M 12 x 35	145	52	68	80	5,74
140	x	190	199	23000	330	123	90	10	M 14 x 40	230	58	76	90	6,92
150	x	200	209	30000	400	136	100	12	M 14 x 40	230	58	76	90	7,24
160	x	210	219	32000	400	132	100	12	M 14 x 40	230	58	76	90	7,76
170	x	225	134	39000	460	145	110	14	M 14 x 40	230	58	76	90	8,98
180	x	235	244	41000	460	133	100	14	M 14 x 40	230	58	76	90	9,50
190	x	250	259	46400	488	137	104	15	M 14 x 40	230	58	76	90	11,10
200	x	260	269	48800	488	131	100	15	M 14 x 40	230	58	76	90	11,70
220	x	285	294	59900	544	103	79	12	M 16 x 50	360	72	98	114	18,30

**TAS**  
**SCHÄFER**



# Friction Springs Industrial Buffers

Damping technology



# Function and structure

## Friction springs Type TAS

The primary function of a friction spring is the damping / absorbing of introduced energy. A friction spring consists of closed outer and inner rings which intermesh with their conical surfaces. As a result of the energy introduced axially, the outer and inner rings on the conical surfaces are shifted apart from each other so that the spring column is shortened. This has the effect that the outer rings stretch and the inner rings reduce in diameter. As a result of the friction arising on the conical surfaces, the introduced energy is absorbed and converted into heat which is to be removed. Resonance effects are suppressed completely.

energy absorption depend on the number of elements. The necessary element number is calculated from the required spring travel  $s$  or the required spring work  $W$ .  $e = \text{stotal} / se = W_{\text{total}} / We$

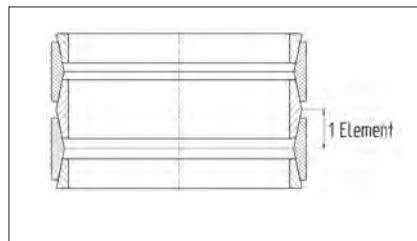

Fig. 1: Friction spring with 4 elements

### Principle of the friction spring

Friction springs consist of outer and inner rings which contact each other on their conical surfaces, with the application of a special lubricant.

If an axial load acts on the friction spring, the conical surfaces slide over one another and cause the outer rings to be lengthened (stretched) and the inner rings to be shortened (compressed). The conical surfaces cause a force and path translation. As a result, a linear spring diagram is plotted.

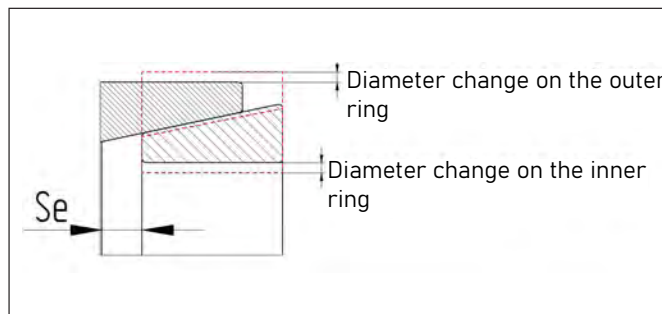

Fig. 2: Friction spring with diameter deviation

An effective conical surface is designated as a spring element, i.e. half an outer ring and half an inner ring.

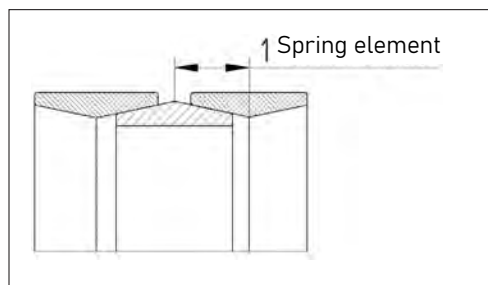

Fig 3: Drawing 2 outer rings and 1 inner ring

Friction springs are structured from similar-type outer and inner rings. As a result of changing the element number, any arbitrary spring travel can be achieved and, as a result, every level of spring stiffness. However, the end force always remains identical in case of different element numbers. Only the spring travel, as well as the spring length, change.

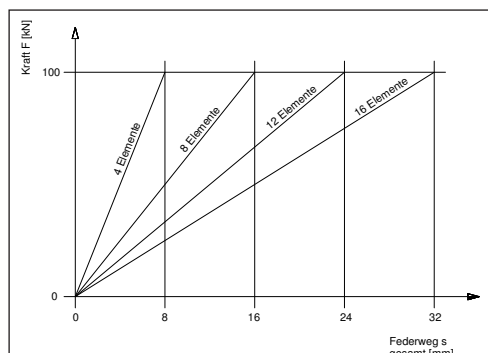

Fig. 4: Characteristic curve changeable by selection of ring number

With the selection of the ring type, the outer and inner diameter, as well as the spring end force, are stipulated. On the other hand, the length spring, spring travel and work



# Function and structure

## Friction springs Type TAS

The friction spring should be designed as far as possible so that it comes to its end with half an inner rings on both sides. This is the most favorable variant. Thus the friction spring consists of:

- 2 Outer rings
- 1 Inner ring
- 2 Half inner rings

If, for construction-technical reasons, the friction spring must end with an uneven element number, it is composed as follows.

- 1 Outer ring
- 1 Inner ring
- 1 Half outer ring
- 1 Half inner ring

Alternatively, a friction spring can also end with 2 half outer rings or whole rings. If friction springs end with one or even two whole rings then, for the calculation of  $L_0$ , half the ring width or twice the half ring width are to be added.

Check: For all correctly composed friction springs, the following applies:

Element number  $e = \text{sum of all spring rings} - 1$

Also nothing changes here if the friction springs are closed off with whole spring rings instead of with half spring rings. The friction spring in Fig. 8 consists of 7 spring rings and accordingly has  $7 - 1 = 6$  elements. With the calculation of the spring length, half the ring width is also to be added.

With this, the non-stressed length  $L_0$  of the friction spring in Fig. 8 is  
 $L_0 = 6 \times h_e + b/2$   
 Values from friction spring table on page 9

For the verification of the spring length, it is not appropriate to measure the non-stressed spring length  $L_0$ .

Because of certain non-circularity values of the spring rings without a load and grease between the tapered surfaces, a spring length  $L_0$  which is too large is mostly measured.

So that the spring rings make complete contact on the tapered surfaces, measuring should be carried out under test load only.

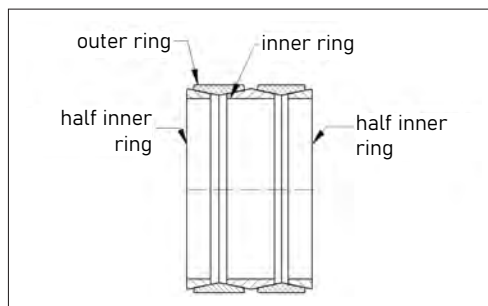

Fig. 5: Friction spring with two HIR

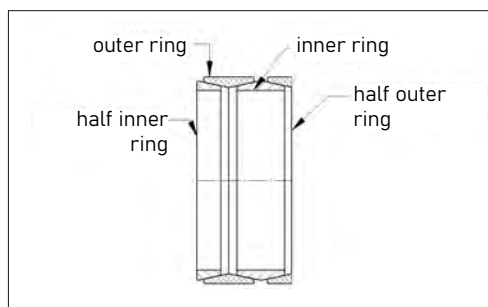

Fig. 6: Friction spring with HOR + HIR

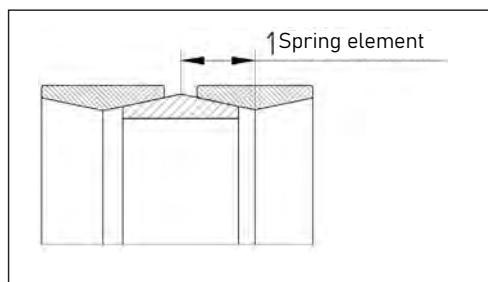

Fig. 7: Friction spring with whole rings at the end

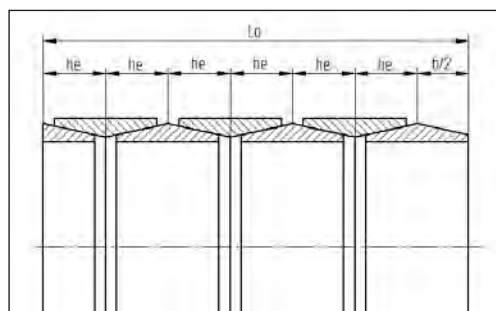

Fig. 8: Friction spring with 6 elements, ends 1 IR + 1 HIR

# Construction notes

## Pre-stressing:

Friction springs are to be pre-stressed with at least 5%, preferably with 10%, of the spring end force. The pre-stressing has the objective of bracing the spring rings against each other and of fixing their location with respect to each other and this has as result that a spring column is aligned in the axial direction.

In order not to impair the lubrication film on the tapered surfaces, the pre-stressing force should not be more than 50% of the later end force.

## Guide:

Friction springs require an inner or outer guide. In the case of short

friction springs ( $L_v \leq 1.5 \times D1$ ) which are loaded between pressure plates guided parallel, a guide can be dispensed with. In case of long friction springs, it is recommended to brace these with two pre-stressed pots as friction spring cartridges.

## Lubrication:

The selection of the lubricant has a large influence on the service life of the friction spring. Optimal spring characteristic values are achieved by the utilization of special lubricants. Therefore only authorized special lubricants should be used to ensure reliable function. On delivery, the friction springs are already lubricated. Since the service life of a friction

spring is in the order of magnitude of the fatigue strength of a friction spring, a later lubrication is dispensed with.

## Sealing:

In order not to impair the lubrication film in case of friction springs, these are to be installed protected against moisture and dust. Simple sliding guides mostly suffice. Otherwise we recommend the installation of a flexible bellows.

# Characteristics

## High level of spring work with low weight and volume:

Since the spring material is fully utilized by the friction spring, the dimensions and the weight can be reduced to a minimum. The spring work per element is the decisive variable here.

## High damping:

As a result of the good damping of a friction spring, where this is 66% as standard, the energy introduced is absorbed quickly and reliably. Furthermore, resonance effects are suppressed completely.

## Overload-secure in block setting:

As a result of their construction as block springs, it is ensured that the friction springs do not exceed their permissible stresses. This prevents damage to the friction springs.

## Independent of the loading rate:

The loading rate is independent of the force-travel diagram. Even with small loading rates, friction springs offer full spring work and damping.

## Diagram independence of the temperature:

In the temperature range  $-40^{\circ}\text{C}$  to  $+80^{\circ}\text{C}$  the characteristic curve of the friction spring is constant. This is different than in the case of hydraulic dampers or synthetic springs, where the force-travel diagram is influenced by fluctuations of temperature and self-heating. The self-heating due to damping is to be considered.

## Zero maintenance:

A relubrication of the spring in operation is generally not necessary. The utilization of other lubricants can even lead to failure of the friction spring.

Can be individually arranged to suit the case of application:

As well as our standard friction springs, we are also glad to offer you solutions individually tailored to your requirements.

## Parallel and series switching:

Given the option to arrange the spring column in 2 different ways, it is possible to use the installation space even more effectively.

# Friction springs

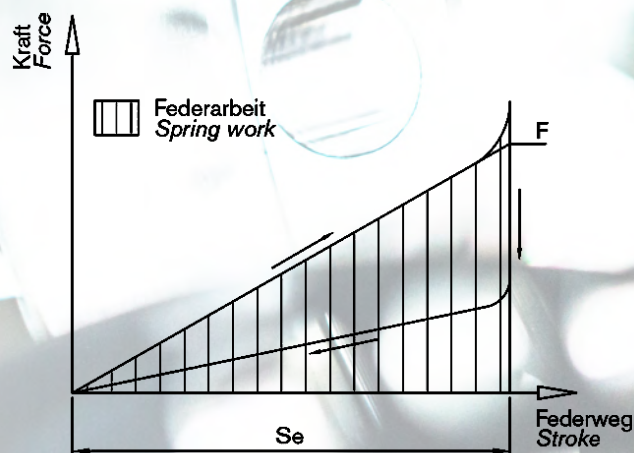
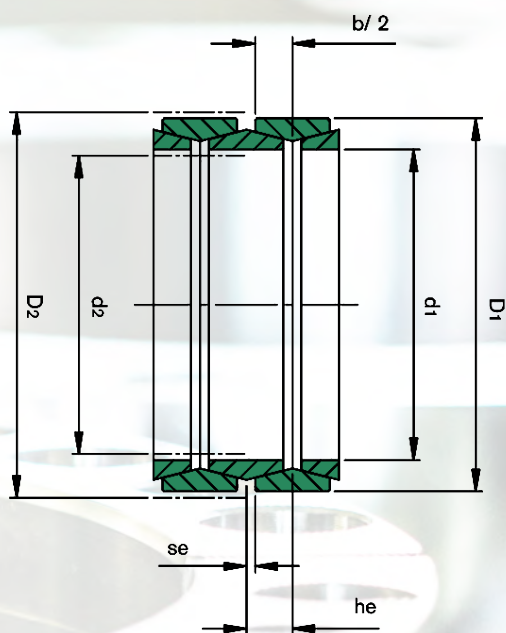

## Used symbols

F	[kN]	Spring end force
$s_e$	[mm]	Spring travel for one element
$h_e$	[mm]	Element height
$W_e$	[J]	Energy absorption (work of one element)
$D_1$	[mm]	Outer diameter
$d_1$	[mm]	Inner diameter
$b/2$	[mm]	Half width of the ring
$D_2$	[mm]	Outer diameter of guide components
$d_2$	[mm]	Inner diameter of guide components

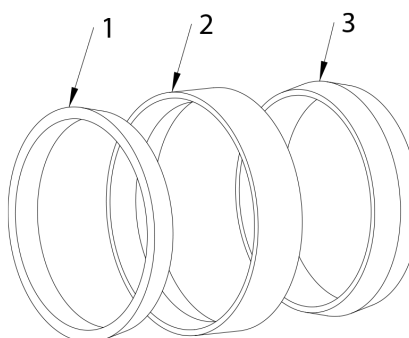

## Order specification:

### Type-Number of spring elements.Index

(e.g.: 06300-4.xxxx\*)

\*Sequential number:

includes references to further product data



# Friction Springs

## Standard dimensions

Type	F kN	S <sub>e</sub> mm	h <sub>e</sub> mm	W <sub>e</sub> J	D <sub>1</sub> mm	d <sub>1</sub> mm	b/2 mm	D <sub>2</sub> mm	d <sub>2</sub> mm	Weight kg
01800	5	0,4	2,2	1,0	18,1	14,4	1,8	18,7	13,9	0,002
02500	9	0,6	3,1	2,7	25,0	20,8	2,5	25,9	20,1	0,004
03200	14	0,8	4,0	5,6	32,0	27,0	3,2	33,1	26,1	0,007
03800	20	0,9	4,7	9,0	38,0	31,7	3,8	39,3	30,6	0,012
04200	27	1,0	5,2	13,5	42,2	34,6	4,2	43,6	33,4	0,017
04800	35	1,1	5,9	19,3	48,2	39,4	4,8	49,8	38,1	0,026
05500	42	1,3	6,8	27,3	55,0	46,0	5,5	56,7	44,5	0,035
06300	55	1,4	7,7	38,5	63,0	51,9	6,3	64,9	50,3	0,056
07000	67	1,6	8,6	53,6	70,0	58,2	7,0	72,1	56,4	0,074
08000	84	1,8	9,8	75,6	80,0	67,0	8,0	83,0	64,0	0,105
09000	100	2,0	11,0	100,0	90,0	75,5	9,0	93,0	72,5	0,145
10000	125	2,2	12,2	137,5	100,0	83,6	10,0	103,0	81,0	0,203
12400	200	2,6	15,0	260,0	124,0	102,0	12,4	127,0	99,0	0,410
13000	160	2,6	15,0	208,0	130,0	111,5	12,4	133,0	108,5	0,376
14000	250	3,0	17,0	375,0	140,0	116,0	14,0	143,0	113,0	0,576
16600*	350	3,7	20,0	648,0	166,0	134,0	16,0	170,0	130,0	0,870
19600	600	4,4	23,4	1320	194,0	155,0	19,0	199,0	150,0	1,680
20000	510	3,9	22,4	995,0	198,0	161,0	18,5	202,0	157,0	1,570
22000	720	4,4	26,4	1584,0	220,0	174,0	22,0	224,0	170,0	2,600
26200	860	4,8	25,8	2064,0	262,0	208,0	21,0	266,0	204,0	3,426
30000	1.000	5,8	35,8	2900,0	300,0	250,0	30,0	305,0	245,0	5,530
32000	1.250	6,2	38,2	3875,0	320,0	263,0	32,0	326,0	258,0	7,100

\*Type 16600 is not a block spring and a separate stroke limit must be provided

# IPA 1

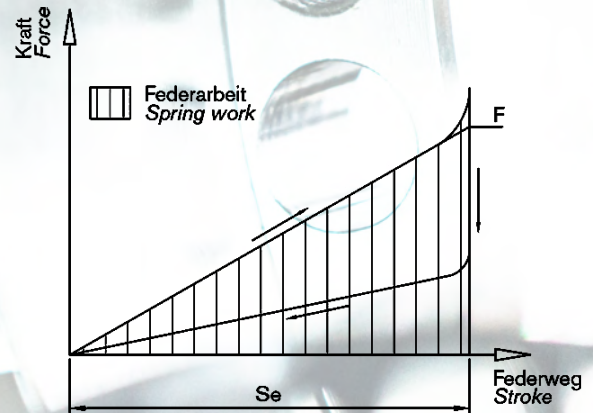
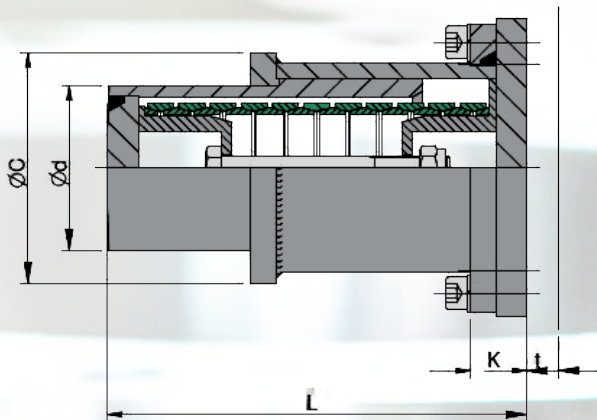

## Used symbols

m	[kg]	Weight
$F_v$	[kN]	Pretensioning force
F	[kN]	Spring force
s	[mm]	Spring travel
W	[J]	Spring work
L	[mm]	Total length
d	[mm]	Plunger diameter
C	[mm]	Case diameter
K	[mm]	Flange thickness
a	[mm]	Flange dimension
b	[mm]	Hole size
$d_1$	[mm]	Flange boring
t	[mm]	Support wall thickness

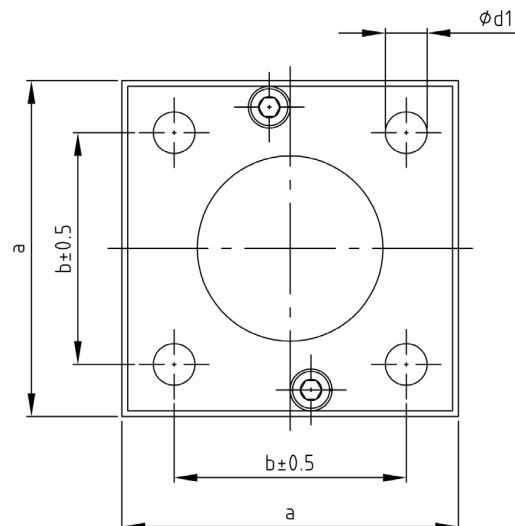

### Order specification:

#### IPA1-Sz.-Type.Index

(e.g.: IPA1-1-06300.xxxx\*)

#### \*Sequential number:

includes references to further product data

# IPA 1

## Standard dimensions

Sz.	Type	Diagram values				Dimensions of the buffer					Connection dimensions			
		$F_V$ kN	$F$ kN	$s$ mm	$W$ J	$L$ mm	$d$ mm	$C$ mm	$K$ mm	$a$ mm	$b$ mm	$d_1$ mm	$t$ mm	$m$ kg
1	06300	6	55	27,4	830	202	80	112	27	145	100	18	15	10,5
2		6	55	37,0	1120	262	80	112	27	145	100	18	15	12,5
3		6	55	54,8	1670	374	80	112	27	145	100	18	15	16,7
4		6	55	64,4	1960	434	80	112	27	145	100	18	15	19,2
5		6	55	74,0	2250	494	80	112	27	145	100	18	15	20,2
6	08000	7	84	33,0	1500	230	96	122	27	160	110	18	15	13,4
7		7	84	46,0	2090	306	96	122	27	160	110	18	15	16,5
8		7	84	66,0	3000	428	96	122	27	160	110	18	15	22,5
9		7	84	79,0	3590	505	96	122	27	160	110	18	15	26,2
10		7	84	92,0	4180	582	96	122	27	160	110	18	15	28,0
11	10000	10	125	44,0	2970	300	114	142	31	185	130	23	20	22,2
12		10	125	60,5	4080	397	114	142	31	185	130	23	20	26,0
13		10	125	89,0	6000	571	114	142	31	185	130	23	20	37,1
14		10	125	105,0	7080	667	114	142	31	185	130	23	20	41,8
15		10	125	121,0	8160	763	114	142	31	185	130	23	20	48,1
16	12400	20	200	51,2	5630	365	142	178	34	215	155	23	20	39,0
17		20	200	64,8	7120	454	142	178	34	215	155	23	20	46,0
18		20	200	102,4	11260	696	142	178	34	215	155	23	20	64,0
19		20	200	116,0	12760	784	142	178	34	215	155	23	20	75,0
20		20	200	130,0	14300	872	142	178	34	215	155	23	20	78,0
21	16600	20	360	75,0	14250	500	184	230	47	270	200	27	25	98,0
22		20	360	95,0	18050	630	184	230	47	270	200	27	25	124,0
23		20	360	142,0	26980	880	184	230	47	270	200	27	25	147,0
24		20	360	170,0	32300	1040	184	230	47	270	200	27	25	150,0
25		20	360	190,0	36100	1200	184	230	47	270	200	27	25	175,0



# IPA 2

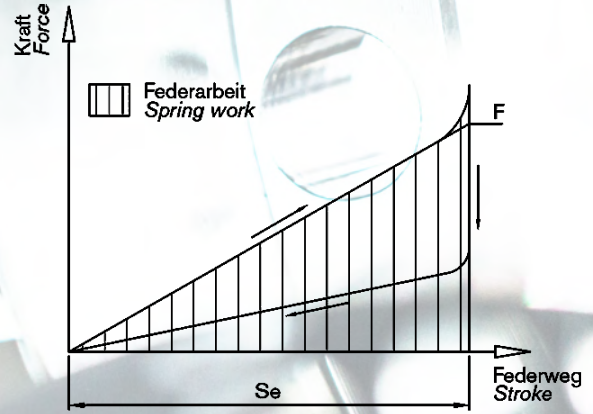
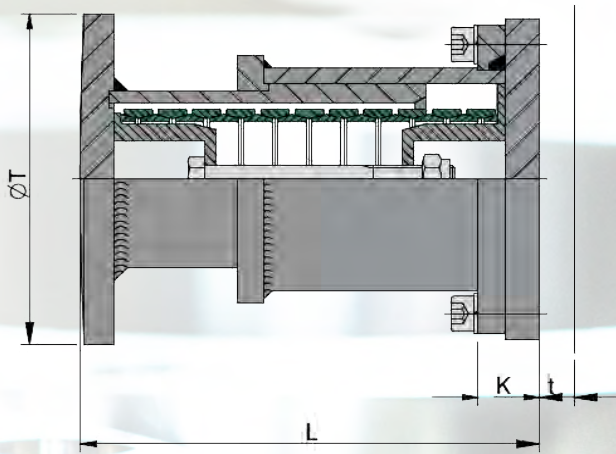

## Used symbols

m	[kg]	Weight
$F_v$	[kN]	Pretensioning force
F	[kN]	Spring force
s	[mm]	Spring travel
W	[J]	Spring work
L	[mm]	Total length
T	[mm]	Baffle diameter
K	[mm]	Flange thickness
a	[mm]	Flange dimension
b	[mm]	Hole size
$d_1$	[mm]	Flange boring
t	[mm]	Support wall thickness

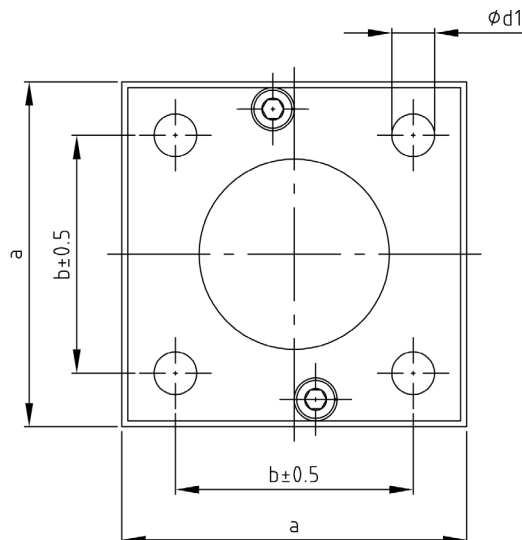

### Order specification:

#### IPA2-Sz.-Type.Index

(e.g.: IPA2-1-06300.xxxx\*)

\*Sequential number:

includes references to further product data

# IPA 2

## Standard dimensions

Sz.	Type	Diagram values				Dimensions of the buffer				Connection dimensions			
		$F_V$ kN	$F$ kN	$s$ mm	$W$ J	$L$ mm	$T$ mm	$K$ mm	$a$ mm	$b$ mm	$d_1$ mm	$t$ mm	$m$ kg
1	06300	6	55	27,4	830	202	150	27	145	100	18	15	12,0
2		6	55	37,0	1120	262	150	27	145	100	18	15	13,8
3		6	55	54,8	1670	374	150	27	145	100	18	15	18,2
4		6	55	64,4	1960	434	150	27	145	100	18	15	20,8
5		6	55	74,0	2250	494	150	27	145	100	18	15	21,5
6	08000	7	84	33,0	1500	230	200	27	160	110	18	15	16,3
7		7	84	46,0	2090	306	200	27	160	110	18	15	19,5
8		7	84	66,0	3000	428	200	27	160	110	18	15	25,5
9		7	84	79,0	3590	505	200	27	160	110	18	15	29,6
10		7	84	92,0	4180	582	200	27	160	110	18	15	31,0
11	10000	10	125	44,0	2970	300	250	31	185	130	23	20	30,0
12		10	125	60,5	4080	397	250	31	185	130	23	20	30,5
13		10	125	89,0	6000	571	250	31	185	130	23	20	38,2
14		10	125	105,0	7080	667	250	31	185	130	23	20	44,8
15		10	125	121,0	8160	763	250	31	185	130	23	20	52,1
16	12400	20	200	51,2	5630	365	250	34	215	155	23	20	45,0
17		20	200	64,8	7120	454	250	34	215	155	23	20	48,0
18		20	200	102,4	11260	696	250	34	215	155	23	20	66,0
19		20	200	116,0	12760	784	250	34	215	155	23	20	77,0
20		20	200	130,0	14300	872	250	34	215	155	23	20	79,0
21	16600	20	360	75,0	14250	500	250	47	270	200	27	25	101,0
22		20	360	95,0	18050	630	250	47	270	200	27	25	126,0
23		20	360	142,0	26980	880	250	47	270	200	27	25	149,0
24		20	360	170,0	32300	1040	250	47	270	200	27	25	152,0
25		20	360	190,0	36100	1200	250	47	270	200	27	25	177,0

# IPA 3

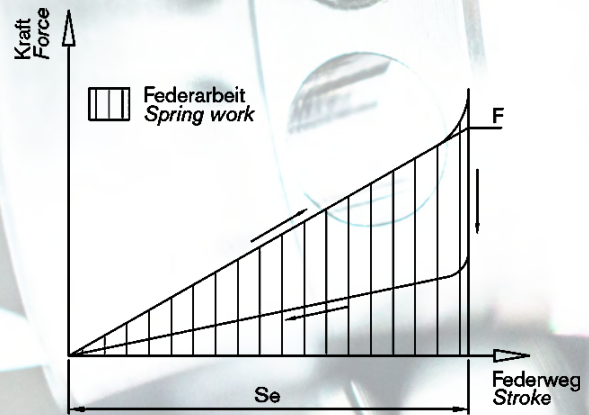
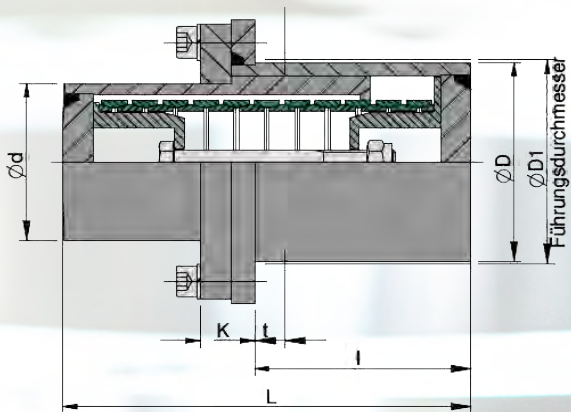

## Used symbols

m	[kg]	Weight
$F_v$	[kN]	Pretensioning force
F	[kN]	Spring force
s	[mm]	Spring travel
W	[J]	Spring work
L	[mm]	Total length
l	[mm]	Dimple length
D	[mm]	Outer diameter
d	[mm]	Plunger diameter
K	[mm]	Flange thickness
a	[mm]	Flange dimension
b	[mm]	Hole size
$d_1$	[mm]	Flange boring
$D_1$	[mm]	Installation diameter
t	[mm]	Support wall thickness

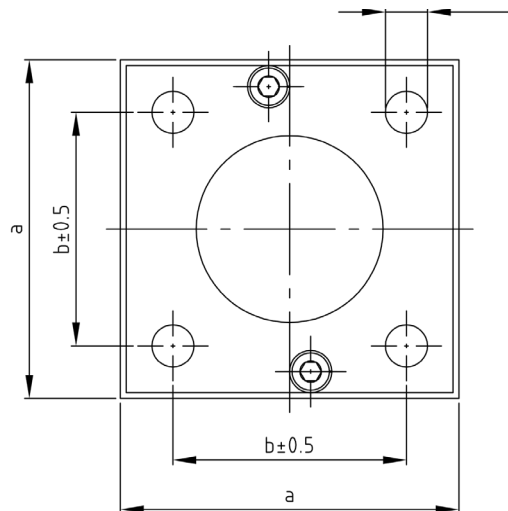
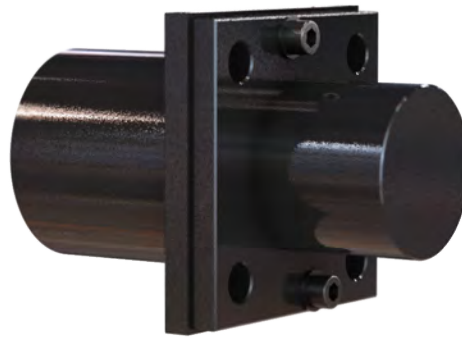

**Order specification:**  
**IPA3-Sz.-Type.Index**  
 (e.g.: IPA3-1-06300.xxxx\*)

\*Sequential number:  
 includes references to further product data



# IPA 3

## Standard dimensions

Sz.	Type	Diagram values				Dimensions of the buffer						Connection dimensions				
		$F_V$	$F$	$s$	$W$	$L$	$l$	$D$	$d$	$K$	$a$	$b$	$d_1$	$D_1$	$t$	$m$
		kN	kN	mm	J	mm	mm	mm	mm	mm	mm	mm	mm	mm	mm	kg
1	06300	6	55	27,4	830	202	107	102	80	27	145	100	18	104	15	10,2
2		6	55	37,0	1120	262	156	102	80	27	145	100	18	104	15	12,5
3		6	55	54,8	1670	374	225	102	80	27	145	100	18	104	15	16,5
4		6	55	64,4	1960	434	293	102	80	27	145	100	18	104	15	19,1
5		6	55	74,0	2250	494	293	102	80	27	145	100	18	104	15	20,1
6	08000	7	84	33,0	1500	230	125	114	96	27	160	110	18	117	15	13,5
7		7	84	46,0	2090	306	170	114	96	27	160	110	18	117	15	16,2
8		7	84	66,0	3000	428	258	114	96	27	160	110	18	117	15	21,7
9		7	84	79,0	3590	505	355	114	96	27	160	110	18	117	15	25,8
10		7	84	92,0	4180	582	360	114	96	27	160	110	18	117	15	27,5
11	10000	10	125	44,0	2970	300	165	133	114	31	185	130	23	135	20	21,5
12		10	125	60,5	4080	397	230	133	114	31	185	130	23	135	20	26,0
13		10	125	89,0	6000	571	350	133	114	31	185	130	23	135	20	36,7
14		10	125	105,0	7080	667	470	133	114	31	185	130	23	135	20	41,3
15		10	125	121,0	8160	763	470	133	114	31	185	130	23	135	20	45,3
16	12400	20	200	51,2	5630	365	216	165	142	34	215	155	23	167	20	35,5
17		20	200	64,8	7120	454	275	165	142	34	215	155	23	167	20	45,0
18		20	200	102,4	11260	696	456	165	142	34	215	155	23	167	20	64,0
19		20	200	116,0	12760	784	574	165	142	34	215	155	23	167	20	74,0
20		20	200	130,0	14300	872	550	165	142	34	215	155	23	167	20	78,0
21	16600	20	360	75,0	14250	500	328	219	184	47	270	200	27	222	25	83,0
22		20	360	95,0	18050	630	450	219	184	47	270	200	27	222	25	106,0
23		20	360	142,0	26980	880	660	219	184	47	270	200	27	222	25	148,0
24		20	360	170,0	32300	1040	687	219	184	47	270	200	27	222	25	151,0
25		20	360	190,0	36100	1200	850	219	184	47	270	200	27	222	25	176,0

# IPA 4

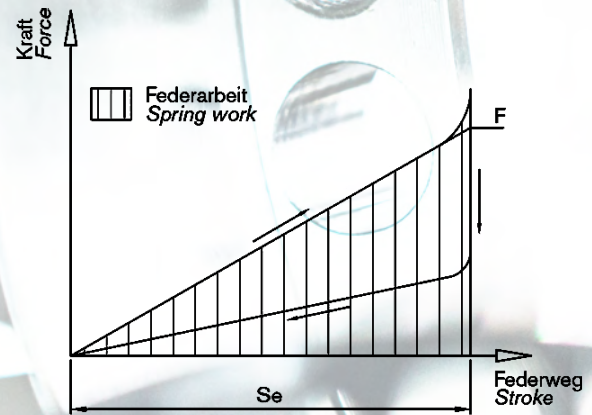
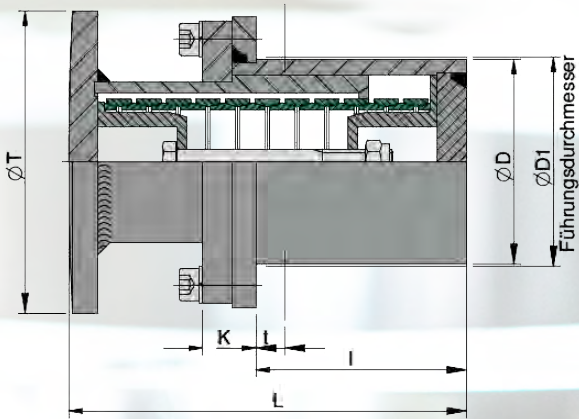

## Used symbols

m	[kg]	Weight
$F_v$	[kN]	Pretensioning force
F	[kN]	Spring force
s	[mm]	Spring travel
W	[J]	Spring work
L	[mm]	Total length
I	[mm]	Dimple length
D	[mm]	Outer diameter
T	[mm]	Baffle diameter
K	[mm]	Flange thickness
a	[mm]	Flange dimension
b	[mm]	Hole size
$d_1$	[mm]	Flange boring
$D_1$	[mm]	Installation diameter
t	[mm]	Support wall thickness

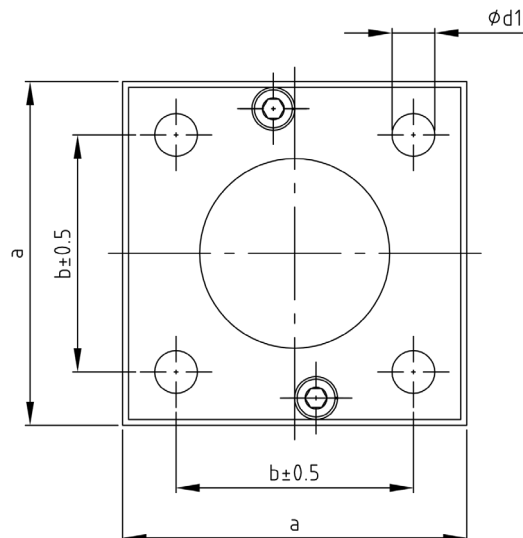
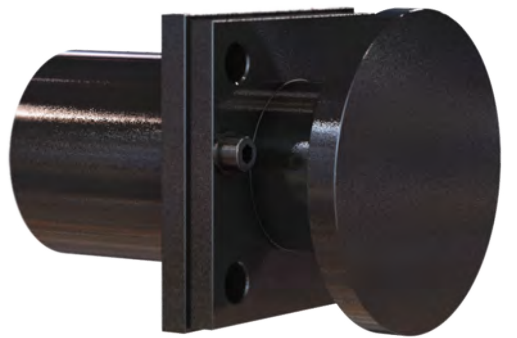

## Order specification:

### IPA4-Gr.-Typ.Index

(e.g.: IPA4-1-06300.xxxx\*)

\*Sequential number:

includes references to further product data

# IPA 4

## Standard dimensions

Sz.	Type	Diagram values				Dimensions of the buffer						Connection dimensions				
		$F_V$	$F$	$s$	$W$	$L$	$I$	$D$	$T$	$K$	$a$	$b$	$d_1$	$D_1$	$t$	$m$
		kN	kN	mm	J	mm	mm	mm	mm	mm	mm	mm	mm	mm	mm	kg
1	06300	6	55	27,4	830	202	107	102	150	27	145	100	18	104	15	11,7
2		6	55	37,0	1120	262	156	102	150	27	145	100	18	104	15	13,4
3		6	55	54,8	1670	374	225	102	150	27	145	100	18	104	15	18,0
4		6	55	64,4	1960	434	293	102	150	27	145	100	18	104	15	20,7
5		6	55	74,0	2250	494	293	102	150	27	145	100	18	104	15	21,4
6	08000	7	84	33,0	1500	230	125	114	200	27	160	110	18	117	15	16,3
7		7	84	46,0	2090	306	170	114	200	27	160	110	18	117	15	19,2
8		7	84	66,0	3000	428	258	114	200	27	160	110	18	117	15	24,7
9		7	84	79,0	3590	505	355	114	200	27	160	110	18	117	15	29,0
10		7	84	92,0	4180	582	360	114	200	27	160	110	18	117	15	30,4
11	10000	10	125	44,0	2970	300	165	133	250	31	185	130	23	135	20	26,6
12		10	125	60,5	4080	397	230	133	250	31	185	130	23	135	20	29,0
13		10	125	89,0	6000	571	350	133	250	31	185	130	23	135	20	37,8
14		10	125	105,0	7080	667	470	133	250	31	185	130	23	135	20	42,3
15		10	125	121,0	8160	763	470	133	250	31	185	130	23	135	20	51,6
16	12400	20	200	51,2	5630	365	216	165	250	34	215	155	23	167	20	44,5
17		20	200	64,8	7120	454	275	165	250	34	215	155	23	167	20	47,5
18		20	200	102,4	11260	696	456	165	250	34	215	155	23	167	20	65,6
19		20	200	116,0	12760	784	574	165	250	34	215	155	23	167	20	76,5
20		20	200	130,0	14300	872	550	165	250	34	215	155	23	167	20	78,4
21	16600	20	360	75,0	14250	500	328	219	250	47	270	200	27	222	25	100,5
22		20	360	95,0	18050	630	450	219	250	47	270	200	27	222	25	125,0
23		20	360	142,0	26980	880	660	219	250	47	270	200	27	222	25	148,2
24		20	360	170,0	32300	1040	687	219	250	47	270	200	27	222	25	151,2
25		20	360	190,0	36100	1200	850	219	250	47	270	200	27	222	25	177,0





# Stainless products

# overview

## Stainless products

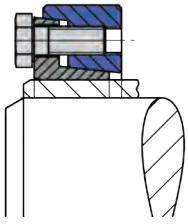

### 3173 1.4122 Shrink Disc 2-parts

Mini-Range, Medium corrosion  
resistance **page 207**

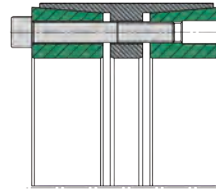

### 3012 S2 Locking Assembly

Very good self-centering,  
Wide installation length,  
Medium corrosion resistance  
**page 217**

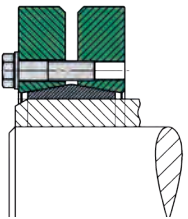

### 3071 1.4122 Shrink Disc 3-parts

Standard-Range, Medium  
corrosion resistance **page 211**

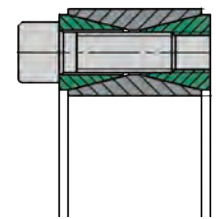

### 3020 S2 Locking Assembly

No self-centering, Short  
installation length, Medium  
corrosion resistance  
**page 219**

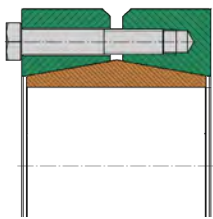

### W 1.4122 Shaft Coupling

Short shaft distance, Medium  
corrosion resistance  
**page 213**





# 3173 1.4122 2-parts (stainless)

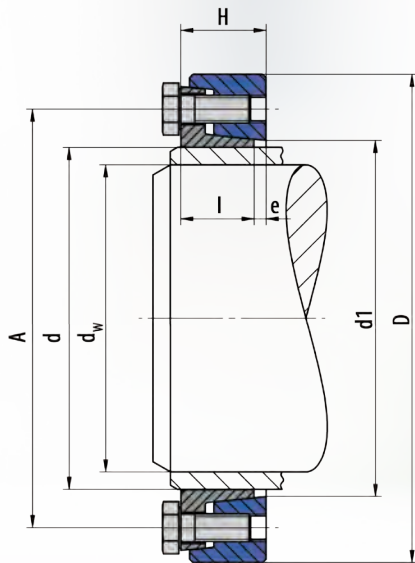

## Used symbols

d	[mm]	Nominal diameter of the shrink disc
d <sub>w</sub>	[mm]	Shaft diameter
M <sub>max</sub>	[mm]	Maximal transmittable torque
D	[mm]	Outer diameter
l	[mm]	Length of the bush
e	[mm]	Excess length
H	[mm]	Width of the shrink disc
A	[mm]	Pitch circle diameter
d <sub>1</sub>	[mm]	Attachment size
M <sub>A</sub>	[Nm]	Tightening torque of the clamping screws
Z		Number of clamping screws
S		Size of the clamping screws
n <sub>max</sub>	[min-1]	Permitted rotational frequency
p <sub>N</sub>	[N/mm <sup>2</sup> ]	Moderate pressure to the hub
I	[kgm <sup>2</sup> ]	Moment of inertia

## Design of the shrink disc

- Without Washers
- Bush complete slit
- Dimensions H & e in unlocked position

min. yield strength Rp0,2	N/mm <sup>2</sup>
solid shaft	240
Hub	290

Variation from the standard shaft diameter dW			
> mm	≤ mm	minimal - mm	maximal + mm
20	60	-2	1
60	100	-2	2
100	160	-3	2
160	220	-4	2
220	300	-5	2

$$M = M_{\max(\text{Catalog})} \left( \frac{d_w(\text{target})}{d_w(\text{Catalog})} \right)^2$$

(see Basics - Calculation)

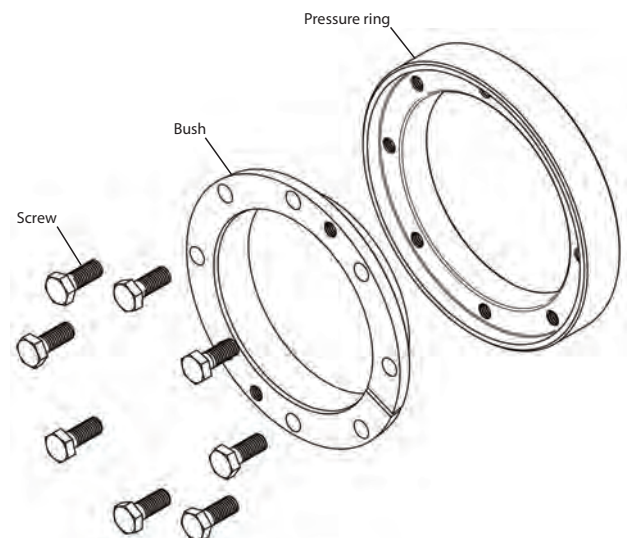

Ordering information: TAS 3173-d (e.g.: TAS 3173-100 1.4122 ... further sizes on request)



# 3173 1.4122 2-parts (stainless)

$d$ mm	$d_w$ mm	$M_{max}$ Nm	$D$ mm	$l$ mm	$e$ mm	$H$ mm	$A$ mm	$d_1$ mm	$M_A$ Nm	$Z$ Stk	$S$	$DIN$	$Class$	$n_{max}$ min <sup>-1</sup>	$p_N$ N/mm <sup>2</sup>	$I$ kgm <sup>2</sup>	$Weight$ kg
24	20	85	50	11	2,5	13,5	38	25	8	6	M 6 x 12	933	A4-K80	11400	161	0,0000538	0,14
29	25	135	58	11	2,5	13,5	44	32	8	6	M 6 x 12	933	A4-K80	9800	150	0,0000964	0,18
34	29	160	64	11	2,5	13,5	50	38	8	6	M 6 x 12	933	A4-K80	8900	134	0,0001402	0,21
35	29	150	64	11	2,5	13,5	50	38	8	6	M 6 x 12	933	A4-K80	8900	135	0,0001387	0,21
38	34	235	69	11	2,5	13,5	55	43	8	6	M 6 x 12	933	A4-K80	8300	123	0,0001869	0,24
40	35	240	69	11	2,5	13,5	55	43	8	6	M 6 x 12	933	A4-K80	8300	124	0,0001826	0,23
44	36	280	80	15	3	18	62	49	8	6	M 6 x 16	933	A4-K80	7100	141	0,0004609	0,44
46	38	330	80	15	3	18	62	49	8	6	M 6 x 16	933	A4-K80	7100	142	0,0004518	0,42
47	40	400	80	15	3	18	62	49	8	6	M 6 x 16	933	A4-K80	7100	144	0,0004469	0,42
51	44	550	85	15	3	18	67	54	8	6	M 6 x 16	933	A4-K80	6700	124	0,0005627	0,46
56	48	570	90	15	3	18	72	59	8	8	M 6 x 16	933	A4-K80	6300	132	0,0006908	0,49
57	48	570	90	15	3	18	72	59	8	8	M 6 x 16	933	A4-K80	6300	130	0,0006818	0,48
61	53	680	95	15	3	18	76	64	8	8	M 6 x 16	933	A4-K80	6000	122	0,0008373	0,53
65	58	740	100	15	3	18	82	69	8	8	M 6 x 16	933	A4-K80	5700	108	0,0010174	0,57
66	58	740	100	15	3	18	82	69	8	8	M 6 x 16	933	A4-K80	5700	110	0,0010035	0,56
70	62	910	115	21	3	24	94	77	19	6	M 8 x 20	933	A4-K80	4900	106	0,0026163	1,15
72	63	940	115	21	3	24	94	77	19	6	M 8 x 20	933	A4-K80	4900	107	0,0025666	1,12
73	63	940	115	21	3	24	94	77	19	6	M 8 x 20	933	A4-K80	4900	111	0,0025402	1,10
75	67	1140	120	21	3	24	100	82	19	6	M 8 x 20	933	A4-K80	4700	101	0,0030441	1,21
76	68	1210	120	21	3	24	100	82	19	6	M 8 x 20	933	A4-K80	4700	103	0,0030170	1,20
78	68	1210	120	21	3	24	100	82	19	6	M 8 x 20	933	A4-K80	4700	102	0,0029536	1,15
81	73	1240	125	21	3	24	104	87	19	8	M 8 x 20	933	A4-K80	4500	92	0,0034868	1,26
83	75	1380	125	21	3	24	104	87	19	8	M 8 x 20	933	A4-K80	4500	95	0,0034103	1,21
85	77	1420	130	21	3	24	110	92	19	8	M 8 x 20	933	A4-K80	4400	92	0,0040762	1,35
86	78	1470	130	21	3	24	110	92	19	8	M 8 x 20	933	A4-K80	4400	92	0,0040037	1,32
88	80	1470	130	21	3	24	110	92	19	8	M 8 x 20	933	A4-K80	4400	95	0,0039124	1,27
93	83	1630	135	21	3,5	24,5	114	97	19	8	M 8 x 20	933	A4-K80	4200	92	0,0044621	1,33
94	85	1800	135	21	3,5	24,5	114	97	19	8	M 8 x 20	933	A4-K80	4200	94	0,0044054	1,30
96	88	1730	140	21	3,5	24,5	120	102	19	8	M 8 x 20	933	A4-K80	4000	83	0,0051883	1,44
98	90	1900	140	21	3,5	24,5	120	102	19	8	M 8 x 20	933	A4-K80	4000	86	0,0050617	1,39
100	92	2140	145	21	3,5	24,5	124	107	19	8	M 8 x 20	933	A4-K80	3900	91	0,0059567	1,53
103	95	2310	145	21	3,5	24,5	124	107	19	8	M 8 x 20	933	A4-K80	3900	92	0,0057132	1,44
106	98	2160	150	21	3,5	24,5	128	112	19	8	M 8 x 20	933	A4-K80	3800	82	0,0065889	1,56
108	100	2340	150	21	3,5	24,5	128	112	19	8	M 8 x 20	933	A4-K80	3800	84	0,0064189	1,50
112	103	2340	160	25	4	29	134	119	19	8	M 8 x 20	933	A4-K80	3500	87	0,0102798	2,16
115	105	2540	160	25	4	29	134	119	19	8	M 8 x 20	933	A4-K80	3500	91	0,0099175	2,04
120	110	3030	169	25	4	29	140	124	19	8	M 8 x 20	933	A4-K80	3400	98	0,0106519	2,06
123	113	2910	169	25	4	29	144	129	19	8	M 8 x 20	933	A4-K80	3300	90	0,0121135	2,22
125	115	3160	169	25	4	29	144	129	19	8	M 8 x 20	933	A4-K80	3300	93	0,0117986	2,14
130	120	3370	174	25	4	29	150	134	19	12	M 8 x 20	933	A4-K80	3200	89	0,0130255	2,21
135	125	3810	179	25	4	29	154	139	19	12	M 8 x 20	933	A4-K80	3200	92	0,0143352	2,28
138	128	3600	184	25	4	29	160	144	19	9	M 8 x 20	933	A4-K80	3100	92	0,0161739	2,45
140	130	3700	184	25	4	29	160	144	19	9	M 8 x 20	933	A4-K80	3100	94	0,0157304	2,35

# 3173 1.4122 2-parts (stainless)

<i>d</i> mm	<i>d<sub>w</sub></i> mm	<i>M<sub>max</sub></i> Nm	<i>D</i> mm	<i>l</i> mm	<i>e</i> mm	<i>H</i> mm	<i>A</i> mm	<i>d<sub>1</sub></i> mm	<i>M<sub>A</sub></i> Nm	<i>Z</i> Pcs.	<i>S</i>	<i>DIN</i>	<i>Class</i>	<i>n<sub>max</sub></i> min <sup>-1</sup>	<i>p<sub>N</sub></i> N/mm <sup>2</sup>	<i>I</i> kgm <sup>2</sup>	<i>Weight</i> kg
145	135	4200	189	25	4	29	164	149	19	12	M 8 x 20	933	A4-K80	3000	87	0,0172140	2,43
150	140	4450	194	25	4,5	29,5	170	154	19	12	M 8 x 20	933	A4-K80	2900	89	0,0187885	2,50
160	150	4900	204	25	4,5	29,5	180	164	19	12	M 8 x 20	933	A4-K80	2800	68	0,0222215	2,64
166	156	5100	214	25	4,5	29,5	190	174	19	12	M 8 x 20	933	A4-K80	2600	66	0,0276174	3,01
170	160	5300	214	25	4,5	29,5	190	174	19	12	M 8 x 20	933	A4-K80	2600	65	0,0260512	2,79
182	170	8350	230	28	5	33	206	186	19	16	M 8 x 20	933	A4-K80	2400	57	0,0393299	3,66
202	190	9670	250	28	5	33	224	206	19	16	M 8 x 20	933	A4-K80	2200	51	0,0518157	4,01
232	220	15450	280	28	6	34	254	236	19	16	M 8 x 20	933	A4-K80	2000	56	0,0751252	4,55
242	230	15700	290	28	6	34	264	246	19	16	M 8 x 20	933	A4-K80	1900	50	0,0842232	4,72
262	250	17000	310	28	6,5	34,5	284	266	19	18	M 8 x 20	933	A4-K80	1800	45	0,1045710	5,08





**TAS**  
SCHÄFER



# 3071 1.4122 3-parts (stainless)

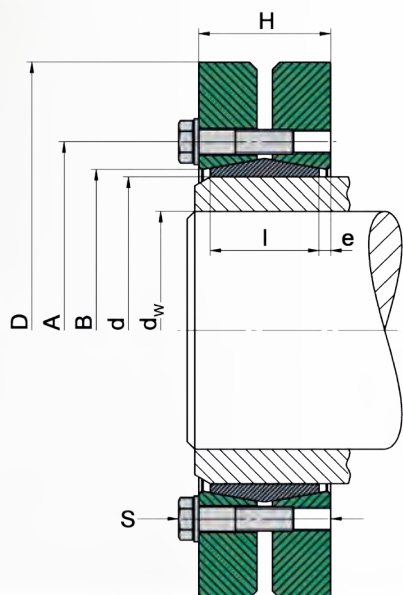

## Used symbols

d	[mm]	Nominal diameter of the shrink disc
$d_w$	[mm]	Shaft diameter
$M_{max}$	[Nm]	Maximal transmittable torque
D	[mm]	Outer diameter
l	[mm]	Length of the inner ring
e	[mm]	Excess length
H	[mm]	Width of the shrink disc
A	[mm]	Pitch circle diameter
B	[mm]	Attachment size
$M_A$	[Nm]	Tightening torque of the clamping screws
Z		Number of clamping screws
S		Size of the clamping screws
$n_{max}$	[min <sup>-1</sup> ]	Permitted rotational frequency
$p_N$	[N/mm <sup>2</sup> ]	Moderate pressure to the hub
I	[kgm <sup>2</sup> ]	Moment of inertia

## Design of the shrink disc

$d < 115$	Without washers
$d \geq 115$	With washers

Dimensions H & e in unlocked position

Hexagon head bolts are used as standard. Upon request we provide all sized shrink discs with hexagon socket head bolts (Inbus). (See ordering information)

Variation from the standard shaft diameter  $d_w$

> mm	≤ mm	minimal - mm	maximal + mm
10	30	-1	1
30	50	-3	2
50	140	-5	5
140	180	-10	5
180	320	-15	10
320	500	-20	10
500	700	-30	20
700	820	-40	20

$$M = M_{max(Catalog)} \left( \frac{d_w(target)}{d_w(Catalog)} \right)^2$$

(see Basics - Calculation)

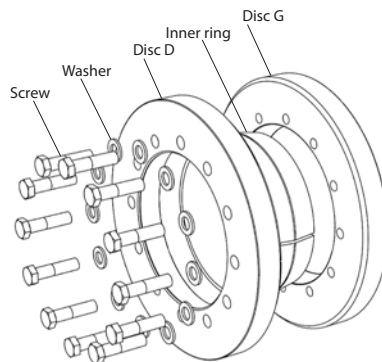

min. yield strength Rp0,2	N/mm <sup>2</sup>
Solid shaft	240
Hub	290

Ordering information: TAS 3071 - d (z.B.: TAS 3071-200 1.4122 ... further sizes on request)  
with Inbus: TAS 3071 - d - Inbus (z.B.: TAS 3071-200-Inbus 1.4122)

# 3071 1.4122 3-parts (stainless)

<i>d</i> mm	<i>d<sub>w</sub></i> mm	<i>M<sub>max</sub></i> Nm	<i>D</i> mm	<i>l</i> mm	<i>e</i> mm	<i>H</i> mm	<i>A</i> mm	<i>B</i> mm	<i>M<sub>A</sub></i> Nm	<i>Z</i> Stk	<i>S</i>	<i>DIN</i>	<i>Class</i>	<i>n<sub>max</sub></i> min <sup>-1</sup>	<i>P<sub>N</sub></i> N/mm <sup>2</sup>	<i>I</i> kgm <sup>2</sup>	<i>Weight</i> kg
14	11	24	37	9	1,5	12	24	15	2,4	3	M 4 x 10	933	A4-K80	15400	223	0,0000137	0,07
16	13	54	41	12	1,5	15	27	17	4,2	3	M 5 x 12	933	A4-K80	13900	213	0,0000266	0,11
18	15	74	43	12	1,5	15	29	19	3,3	4	M 5 x 12	933	A4-K80	13300	198	0,0000326	0,12
20	17	140	48	14	2,75	19,5	34	24	3,9	5	M 5 x 18	933	A4-K80	11900	226	0,0000642	0,19
21	18	160	48	14	2,75	19,5	34	24	3,9	5	M 5 x 18	933	A4-K80	11900	215	0,0000618	0,18
22	19	150	48	14	2,75	19,5	36	26	3,6	5	M 5 x 18	933	A4-K80	11900	190	0,0000627	0,18
24	20	160	50	14	2,5	19	36	26	3,3	6	M 5 x 18	933	A4-K80	11400	191	0,0000731	0,19
30	25	300	60	16	2,75	21,5	44	32	4,6	6	M 5 x 18	933	A4-K80	9500	187	0,0001687	0,30
36	30	440	72	18	2,75	23,5	52	38	8,2	5	M 6 x 20	933	A4-K80	7900	167	0,0003888	0,48
38	31	620	80	20	3	26	56	41	8,2	7	M 6 x 25	933	A4-K80	7100	199	0,0006569	0,67
40	32	500	75	19	2,75	24,5	57	43	8,2	6	M 6 x 20	933	A4-K80	7600	170	0,0004967	0,55
41	33	620	80	20	2,75	25,5	61	46	8	7	M 6 x 20	933	A4-K80	7100	180	0,0006465	0,64
44	35	640	80	20	2,75	25,5	61	47	8	7	M 6 x 20	933	A4-K80	7100	168	0,0006356	0,61
50	40	890	90	22	3	28	70	53	8,2	8	M 6 x 25	933	A4-K80	6300	157	0,0010998	0,83
55	45	1000	100	23	3,75	30,5	75	58	8,2	8	M 6 x 25	933	A4-K80	5700	137	0,0017909	1,1
62	50	1400	110	23	3,75	30,5	86	66	8,2	10	M 6 x 25	933	A4-K80	5200	151	0,0025909	1,3
68	55	1500	115	23	3,75	30,5	86	72	8,2	10	M 6 x 25	933	A4-K80	4900	138	0,0031236	1,4
75	60	2400	138	25	3,75	32,5	100	79	20	7	M 8 x 30	933	A4-K80	4100	162	0,0070923	2,3
80	65	2700	145	25	3,75	32,5	100	84	20	7	M 8 x 30	933	A4-K80	3900	152	0,0085703	2,5
90	70	4000	155	30	4,5	39	114	94	20	10	M 8 x 35	931	A4-K80	3600	161	0,0132516	3,3
100	75	4800	170	34	5	44	124	104	20	12	M 8 x 35	931	A4-K80	3300	154	0,0213950	4,4
110	80	5900	185	39	5,5	50	136	114	39,5	9	M 10 x 40	931	A4-K80	3000	145	0,0347437	6,0
115	80	6100	200	40	5	50	150	124	39,5	10	M 10 x 40	931	A4-K80	2800	150	0,0485678	7,3
120	85	10400	200	40	5	50	150	124	39,5	10	M 10 x 40	931	A4-K80	2800	144	0,0476000	7,0
125	90	8600	215	42	6	54	160	134	39,5	12	M 10 x 40	931	A4-K80	2600	158	0,0672619	8,7
140	100	11800	230	46	7,25	60,5	175	146	68	10	M 12 x 45	931	A4-K80	2400	157	0,0996875	11
155	110	15800	265	50	7,25	64,5	192	165	68	12	M 12 x 50	931	A4-K80	2100	156	0,1885000	16
165	120	25200	290	56	7,5	71	210	175	166	8	M 16 x 55	931	A4-K80	1900	175	0,3061438	22
175	130	27800	300	56	7,5	71	220	185	166	8	M 16 x 55	931	A4-K80	1900	165	0,3467969	23

# W 1.4122 (stainless)

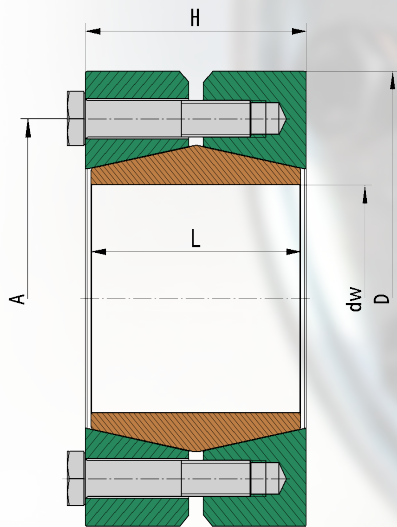

## Used symbols

$d_w$ [mm]	Shaft diameter	
$M_{max}$ [Nm]	max. transmittable torque	$F_{ax} = 0$
$F_{ax}$ [kN]	max. transmittable axial force	$M_t = 0$
D [mm]	Outer diameter of coupling	
L [mm]	Length of sleeve	
H [mm]	Width of shaft coupling	
A [mm]	Pitch circle diameter of bolting	
$M_A$	Required tightening torque of clamping screws	
Z	Number of screws	
S	Size of screws	
$p_w$ [N/mm <sup>2</sup> ]	Average contact pressure on the shaft	

## Design of the disc

$d < 070$	Discs without washers
$d \geq 070$	Discs with washers

Dimensions H & e in unlocked position

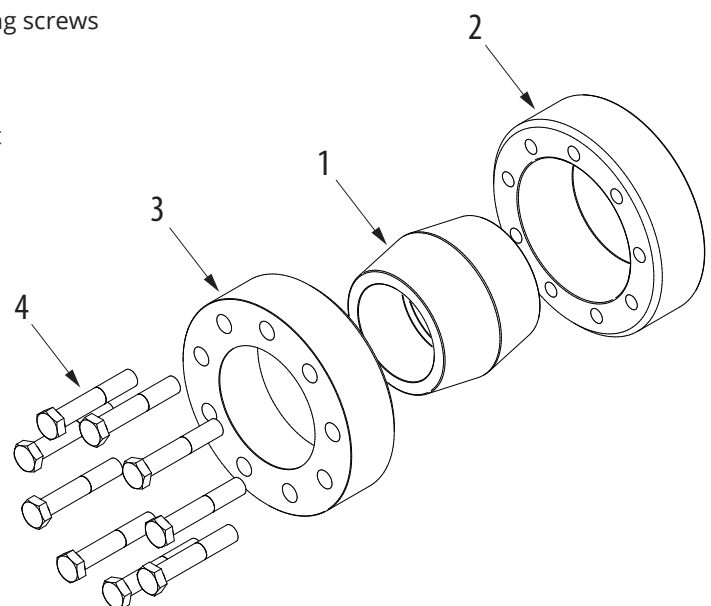

Pos.	Designation
1	Sleeve
2	Pressure ring G
3	Pressure ring Dg
4	Screw

Ordering information: TAS W-Typ/d1/ d2 (e.g: TAS W070/065/070 1.4122 ...  
further sizes on request)



# W 1.4122 (stainless)

Type	$d_w$	$M_{max}$	$F_{ax}$	$D$	$L$	$H$	$A$	$M_A$	$Z$	$S$	DIN	Class	$pw$	Weight
mm	mm	Nm	kN	mm	mm	mm	mm	mm	Pcs.				N/mm <sup>2</sup>	Kg
<b>W015</b>	15	75	10	55	30	33	37	5,8	7	M5 x 25	933	A4-K80	95	0,5
<b>W015</b>	17	137	16	55	30	33	37	5,8	7	M5 x 25	933	A4-K80	135	0,5
<b>W020</b>	18	105	12	60	34	37	42	7,5	8	M6 x 30	931	A4-K80	81	0,7
<b>W020</b>	20	155	16	60	34	37	42	7,4	8	M6 x 30	931	A4-K80	97	0,7
<b>W020</b>	22	241	22	60	34	37	42	7,4	8	M6 x 30	931	A4-K80	125	0,7
<b>W025</b>	23	250	22	66	38	41	48	9,3	8	M6 x 30	931	A4-K80	106	0,8
<b>W025</b>	25	355	28	66	38	41	48	9,4	8	M6 x 30	931	A4-K80	127	0,8
<b>W025</b>	27	475	35	66	38	41	48	9,4	8	M6 x 30	931	A4-K80	146	0,8
<b>W030</b>	28	435	31	76	42	45	54	8,2	10	M6 x 35	931	A4-K80	113	1,3
<b>W030</b>	30	562	37	76	42	45	54	8,2	10	M6 x 35	931	A4-K80	127	1,3
<b>W030</b>	32	667	42	76	42	45	54	8,2	10	M6 x 35	931	A4-K80	132	1,3
<b>W035</b>	33	510	31	80	46	49	62	8,2	12	M6 x 35	931	A4-K80	87	1,5
<b>W035</b>	35	660	38	80	46	49	62	8,2	12	M6 x 35	931	A4-K80	100	1,5
<b>W035</b>	37	820	44	80	46	49	62	8,2	12	M6 x 35	931	A4-K80	111	1,5
<b>W040</b>	38	810	43	98	50	54	71	20	8	M8 x 40	931	A4-K80	96	2,5
<b>W040</b>	40	985	49	98	50	54	71	20	8	M8 x 40	931	A4-K80	105	2,5
<b>W040</b>	43	1280	60	98	50	54	71	20	8	M8 x 40	931	A4-K80	118	2,5
<b>W050</b>	44	1440	65	115	60	64	86	39,5	8	M10 x 45	931	A4-K80	106	4
<b>W050</b>	50	2190	88	115	60	64	86	39,5	8	M10 x 45	931	A4-K80	124	4
<b>W050</b>	54	2700	100	115	60	64	86	39,5	8	M10 x 45	931	A4-K80	131	4
<b>W060</b>	55	2560	93	125	70	74	98	39,5	10	M10 x 50	931	A4-K80	103	5,3
<b>W060</b>	60	3420	114	125	70	74	98	39,5	10	M10 x 50	931	A4-K80	116	5,3
<b>W060</b>	64	4200	131	125	70	74	98	39,5	10	M10 x 50	931	A4-K80	125	5,3
<b>W070</b>	65	4110	126	148	80	85	112	39,5	12	M10 x 60	931	A4-K80	104	8,4
<b>W070</b>	70	5200	149	148	80	85	112	39,5	12	M10 x 60	931	A4-K80	113	8,4
<b>W070</b>	74	6170	167	148	80	85	112	39,5	12	M10 x 60	931	A4-K80	120	8,4
<b>W080</b>	75	6950	185	170	94	99	130	68	12	M12 x 70	931	A4-K80	112	13,1
<b>W080</b>	80	8400	210	170	94	99	130	68	12	M12 x 70	931	A4-K80	119	13,1
<b>W080</b>	84	9280	221	170	94	99	130	68	12	M12 x 70	931	A4-K80	119	13,1
<b>W090</b>	85	8550	201	185	104	109	145	166	7	M16 x 80	931	A4-K80	99	17
<b>W090</b>	90	10250	228	185	104	109	145	166	7	M16 x 80	931	A4-K80	106	17
<b>W090</b>	94	11730	250	185	104	109	145	166	7	M16 x 80	931	A4-K80	111	17
<b>W100</b>	95	13400	335	200	114	119	158	166	9	M16 x 90	931	A4-K80	113	21
<b>W100</b>	100	15580	312	200	114	119	158	166	9	M16 x 90	931	A4-K80	119	21
<b>W100</b>	104	17450	336	200	114	119	158	166	9	M16 x 90	931	A4-K80	123	21
<b>W110</b>	105	19700	375	217	124	129	170	156	12	M16 x 90	931	A4-K80	125	27
<b>W110</b>	110	22400	407	217	124	129	170	156	12	M16 x 90	931	A4-K80	129	27
<b>W110</b>	114	24750	434	217	124	129	170	156	12	M16 x 90	931	A4-K80	133	27
<b>W120</b>	115	25800	449	235	134	139	184	166	13	M16 x 90	931	A4-K80	126	33
<b>W120</b>	120	28960	483	235	134	139	184	166	13	M16 x 90	931	A4-K80	130	33
<b>W120</b>	124	31260	504	235	134	139	184	166	13	M16 x 90	931	A4-K80	131	33

# W 1.4122 (stainless)

Type	$d_w$ mm	$M_{max}$ Nm	$F_{ax}$ kN	$D$ mm	$L$ mm	$H$ mm	$A$ mm	$M_A$ mm	$Z$ Pcs.	$S$	DIN	Class	$p_w$ N/mm <sup>2</sup>	Weight Kg
<b>W130</b>	125	32580	521	267	150	155	206	326	10	M20 x 110	931	A4-K80	123	45
<b>W130</b>	130	35770	550	267	150	155	206	326	10	M20 x 110	931	A4-K80	125	45
<b>W130</b>	134	39250	586	267	150	155	206	326	10	M20 x 110	931	A4-K80	129	45
<b>W140</b>	135	39350	583	280	160	165	218	326	11	M20 x 110	931	A4-K80	121	55
<b>W140</b>	140	43410	620	280	160	165	218	326	11	M20 x 110	931	A4-K80	124	55
<b>W140</b>	144	46820	650	280	160	165	218	326	11	M20 x 110	931	A4-K80	127	55
<b>W150</b>	145	47120	650	302	170	175	230	326	12	M20 x 120	931	A4-K80	118	70
<b>W150</b>	150	51560	687	302	170	175	230	326	12	M20 x 120	931	A4-K80	121	70





**TAS**  
SCHÄFER



# 3012 S2 (stainless)

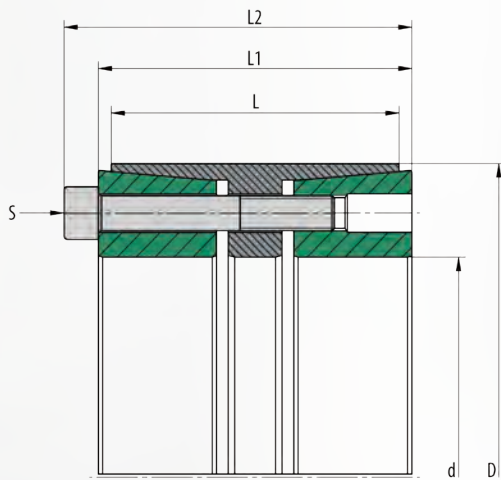

## Used symbols

$d$	[mm]	Shaft diameter	
$D$	[mm]	Hub inside diameter	
$M_t$	[Nm]	Max. transmittable torque	$F_{ax} = 0$
$F_{ax}$	[kN]	Max. transmittable axial force	$M_t = 0$
$p_w$	[N/mm <sup>2</sup> ]	Average pressure on the shaft	
$p_N$	[N/mm <sup>2</sup> ]	Average pressure on the hub	
$L$	[mm]	Length of the sleeve	
$L_1$	[mm]	Width of the locking device without screws	
$L_2$	[mm]	Width of the locking device with screws	
$Z$		Number of clamping screws	
$S$		Size of the clamping screws	
$M_A$	[Nm]	Tightening torque of the clamping screws	

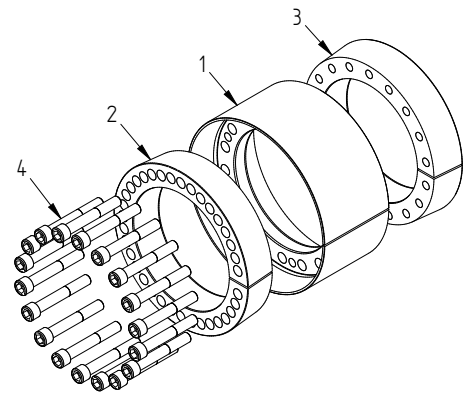

## Recommended tolerances & surfaces

Shaft	h8 / Rz10
Hub	H8 / Rz10

## Bending loads

Bending moment (share)	$M_B \text{ max} = 0,4 * M_t$
Bending angle	max. 5°

## More properties

- low axial displacement during assembly
- very good self-centering
- high self-locking

Pos.	Benennung
1	Sleeve
2	Pressure ring 1
3	Pressure ring 2
4	Screw

Ordering information: TAS 3012/d/D S2 (z.B: TAS 3012/150/200 ... further sizes on request)

# 3012 S2 (stainless)

<b>d</b> mm	<b>D</b> mm	<b>M<sub>max</sub></b> Nm	<b>F<sub>ax</sub></b> kN	<b>p<sub>w</sub></b> N/mm <sup>2</sup>	<b>p<sub>N</sub></b> N/mm <sup>2</sup>	<b>Z</b> Pcs.	<b>S</b>	<b>M<sub>A</sub></b> Nm	<b>L</b> mm	<b>L<sub>1</sub></b> mm	<b>L<sub>2</sub></b> mm	<b>Class</b>	<b>Weight</b> Kg
25	x 50	415	33	95	39	5	M6 x 045	10,3	45	53	59	A4-K80	0,5
30	x 55	598	40	95	43	6	M6 x 045	10,3	45	55	61	A4-K80	0,6
35	x 60	814	46	95	46	7	M6 x 045	10,3	45	55	61	A4-K80	0,7
38	x 65	1009	53	100	48	8	M6 x 045	10,3	45	55	61	A4-K80	0,8
40	x 65	1063	53	95	48	8	M6 x 045	10,3	45	55	61	A4-K80	0,7
45	x 75	1926	86	148	69	7	M8 x 050	25	44	54	62	A4-K80	1,0
50	x 80	2446	98	118	58	8	M8 x 050	25	56	64	72	A4-K80	1,3
55	x 85	3026	110	121	61	9	M8 x 050	25	56	64	72	A4-K80	1,5
60	x 90	3668	122	123	64	10	M8 x 050	25	56	64	72	A4-K80	1,6
65	x 95	3974	122	113	61	10	M8 x 050	25	56	64	72	A4-K80	1,7
70	x 110	6813	195	132	67	10	M10 x 060	49,5	70	78	88	A4-K80	3,1
80	x 120	8565	214	127	68	11	M10 x 060	49,5	70	78	88	A4-K80	3,5
90	x 130	10512	234	123	68	12	M10 x 060	49,5	70	78	88	A4-K80	3,8
100	x 145	15607	312	118	63	11	M12 x 080	86	90	100	112	A4-K80	6,1
110	x 155	18729	341	117	65	12	M12 x 080	86	90	100	112	A4-K80	6,6
120	x 165	23836	397	125	71	14	M12 x 080	86	90	100	112	A4-K80	7,1
130	x 180	30378	467	114	66	12	M14 x 090	137	104	116	130	A4-K80	9,9
140	x 190	38167	545	123	73	14	M14 x 090	137	104	116	130	A4-K80	10,6
150	x 200	43814	584	123	75	15	M14 x 090	137	104	116	130	A4-K80	11,2
160	x 210	49851	623	123	76	16	M14 x 090	137	104	118	132	A4-K80	11,9
170	x 225	63589	748	106	66	14	M16 x 110	212	134	146	162	A4-K80	17,9
180	x 235	72139	802	107	68	15	M16 x 110	212	134	146	162	A4-K80	18,9
190	x 250	81223	855	109	68	16	M16 x 110	212	134	146	162	A4-K80	21,8
200	x 260	85498	855	103	65	16	M16 x 110	212	134	146	162	A4-K80	22,8
220	x 285	105804	962	105	67	18	M16 x 110	212	134	146	162	A4-K80	27,1
240	x 305	128248	1069	107	69	20	M16 x 110	212	134	146	162	A4-K80	29,3

# 3020 S2 (stainless)

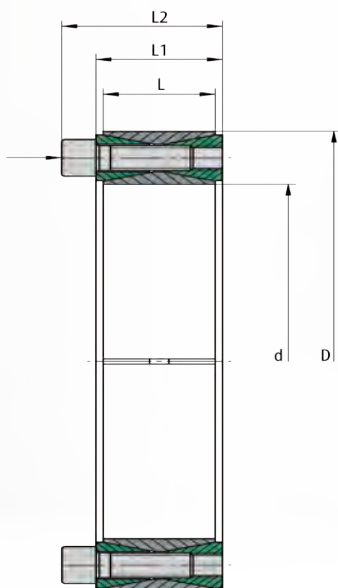

## Used symbols

$d$	[mm]	Shaft diameter	
$D$	[mm]	Hub inside diameter	
$M_t$	[Nm]	Max. transmittable torque	$F_{ax} = 0$
$F_{ax}$	[kN]	Max. transmittable axial force	$M_t = 0$
$p_W$	[N/mm <sup>2</sup> ]	Average pressure on the shaft	
$p_N$	[N/mm <sup>2</sup> ]	Average pressure on the hub	
$L$	[mm]	Length of the sleeve inside and outside	
$L_1$	[mm]	Width of the locking device without screws	
$L_2$	[mm]	Width of the locking device with screws	
$Z$		Number of clamping screws	
$S$		Size of the clamping screws	
$M_A$	[Nm]	Tightening torque of the clamping screws	

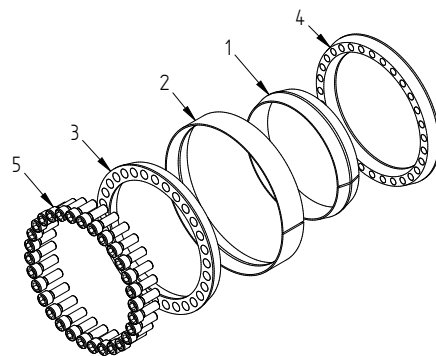

## Recommended tolerances & surfaces

Shaft	from h11 to k11 / Rz10
Hub	from H11 to N11 / Rz10

## Bending loads

Bending moment (share)	depending on hub
Bending angle	max. 2°

## More properties

- no axial displacement during assembly
- no self-centering
- no self-locking

Pos.	Designation
1	Sleeve
2	Outer ring
3	Pressure ring 1
4	Pressure ring 2
5	Screw

Ordering information: TAS 3020/d/D S2 (z.B: TAS 3020/150/200 ... further sizes on request)



# 3020 S2 (stainless)

<b>d</b> mm	<b>x</b>	<b>D</b> mm	<b>M<sub>max</sub></b> Nm	<b>F<sub>ax</sub></b> kN	<b>p<sub>w</sub></b> N/mm <sup>2</sup>	<b>p<sub>N</sub></b> N/mm <sup>2</sup>	<b>Z</b> Pcs.	<b>S</b>	<b>M<sub>A</sub></b> Nm	<b>L</b> mm	<b>L<sub>1</sub></b> mm	<b>L<sub>2</sub></b> mm	<b>Class</b>	<b>Weight</b> kg
17	x	47	168	20	181	66	8	M6 x 018	10,3	17	20	27,5	A4-K80	0,23
18	x	47	178	20	171	66	8	M6 x 018	10,3	17	20	27,5	A4-K80	0,23
19	x	47	188	20	162	66	8	M6 x 018	10,3	17	20	27,5	A4-K80	0,23
20	x	47	198	20	154	66	8	M6 x 018	10,3	17	20	27,5	A4-K80	0,23
22	x	47	217	20	140	66	8	M6 x 018	10,3	17	20	27,5	A4-K80	0,23
24	x	50	237	20	129	62	9	M6 x 018	10,3	17	20	27,5	A4-K80	0,26
25	x	50	247	20	123	62	9	M6 x 018	10,3	17	20	27,5	A4-K80	0,25
28	x	55	415	30	165	84	10	M6 x 018	10,3	17	20	27,5	A4-K80	0,30
30	x	55	445	30	154	84	10	M6 x 018	10,3	17	20	27,5	A4-K80	0,29
32	x	60	474	30	145	77	12	M6 x 018	10,3	17	20	27,5	A4-K80	0,32
35	x	60	519	30	132	77	12	M6 x 018	10,3	17	20	27,5	A4-K80	0,32
38	x	65	704	37	152	89	14	M6 x 018	10,3	17	20	27,5	A4-K80	0,34
40	x	65	741	37	145	89	14	M6 x 018	10,3	17	20	27,5	A4-K80	0,34
42	x	75	1146	55	172	97	12	M8 x 022	25	20	24	33,5	A4-K80	0,57
45	x	75	1228	55	161	97	12	M8 x 022	25	20	24	33,5	A4-K80	0,57
48	x	80	1310	55	151	91	12	M8 x 022	25	20	24	33,5	A4-K80	0,60
50	x	80	1365	55	145	91	12	M8 x 022	25	20	24	33,5	A4-K80	0,60
55	x	85	1877	68	165	106	14	M8 x 022	25	20	24	33,5	A4-K80	0,63
60	x	90	2047	68	151	101	14	M8 x 022	25	20	24	33,5	A4-K80	0,69
65	x	95	2218	68	139	95	16	M8 x 022	25	20	24	33,5	A4-K80	0,73
70	x	110	3802	109	172	109	14	M10 x 025	49,5	24	28	39,5	A4-K80	1,26
75	x	115	4074	109	160	104	14	M10 x 025	49,5	24	28	39,5	A4-K80	1,33
80	x	120	4345	109	150	100	14	M10 x 025	49,5	24	28	39,5	A4-K80	1,40
85	x	125	4617	109	141	96	16	M10 x 025	49,5	24	28	39,5	A4-K80	1,49
90	x	130	4888	109	133	92	16	M10 x 025	49,5	24	28	39,5	A4-K80	1,53
95	x	135	6192	130	152	107	18	M10 x 025	49,5	24	28	39,5	A4-K80	1,62
100	x	145	7918	158	162	111	14	M12 x 030	86	26	33	47	A4-K80	2,01
110	x	155	8709	158	147	104	14	M12 x 030	86	26	33	47	A4-K80	2,15
120	x	165	10135	169	144	104	16	M12 x 030	86	26	33	47	A4-K80	2,35
130	x	180	13724	211	127	92	20	M12 x 035	86	34	38	52	A4-K80	3,51
140	x	190	16258	232	129	95	22	M12 x 035	86	34	38	52	A4-K80	3,85
150	x	200	19002	253	132	99	24	M12 x 035	86	34	38	52	A4-K80	4,07
160	x	210	21958	274	134	102	26	M12 x 035	86	34	38	52	A4-K80	4,03
170	x	225	27094	319	131	99	22	M14 x 040	137	38	44	60	A4-K80	5,78
180	x	235	31296	348	135	103	24	M14 x 040	137	38	44	60	A4-K80	6,05
190	x	250	38541	406	123	94	28	M14 x 045	137	46	52	68	A4-K80	8,25
200	x	260	43467	435	125	96	30	M14 x 045	137	46	52	68	A4-K80	8,65
220	x	285	56856	517	125	96	26	M16 x 050	212	50	56	74	A4-K80	11,22
240	x	305	71567	596	132	104	30	M16 x 050	212	50	56	74	A4-K80	12,20



# THE NEXT GENERATION OF FLANGE COUPLINGS

- **Very fast clamping with optional TAS hydraulic tool**
- **Increased bending load capacity**
- **Reduced mass and inertia**
- **Improved corrosive protection**
- **Simplyfied handling**
- **Vertical use without restriction**
- **Fully Compatible with TAS FK(B) series**

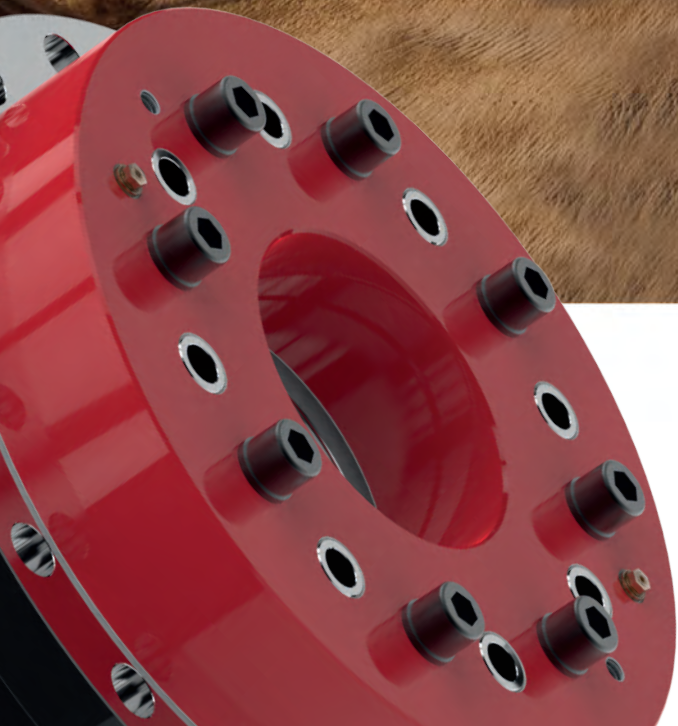

**TAS**  
**SCHÄFER**



[www.tas-schaefer.de](http://www.tas-schaefer.de)

MAIL: [info@tas-schaefer.de](mailto:info@tas-schaefer.de) | TEL.: +49 (0) 2335 9781-0



# Overview further products

Typ	Characteristics	S1	S2	S3	
		1.4571	1.4122	1.4462	
3003	Corrosion resistance	medium	high	very high	Internal Locking Devices
	Material of screws	A4	A4	A4	
	Torque	low	high	medium	
3006	Corrosion resistance	medium	high	very high	
	Material of screws	A4	A4	A4	
	Torque	low	high	medium	
3012	Corrosion resistance	/	high	very high	
	Material of screws	/	A4	A4	
	Torque	/	high	medium	
3015	Corrosion resistance	/	high	very high	
	Material of screws	/	A4	A4	
	Torque	/	high	medium	
3020	Corrosion resistance	medium	high	very high	
	Material of screws	A4	A4	A4	
	Torque	low	high	medium	
3173	Corrosion resistance	medium	high	very high	Shrink Discs
	Material of screws	A4	A4	A4	
	Torque	low	hoch	medium	
3073	Corrosion resistance	medium	high	very high	
	Material of screws	A4	A4	A4	
	Torque	low	high	medium	
3071	Corrosion resistance	medium	high	very high	
	Material of screws	A4	A4	A4	
	Torque	low	high	medium	
3091	Corrosion resistance	medium	high	very high	
	Material of screws	A4	A4	A4	
	Torque	low	high	medium	
W	Corrosion resistance	medium	high	very high	Shaft Coupling
	Material of screws	A4	A4	A4	
	Torque	low	high	medium	
WLA	Corrosion resistance	medium	high	very high	
	Material of screws	A4	A4	A4	
	Torque	low	high	medium	
WK	Corrosion resistance	medium	high	very high	
	Material of screws	A4	A4	A4	
	Torque	low	high	medium	



# PRODUCT OVERVIEW

## EXTRACT

### Drive pulleys

V-belt pulleys | V-belt pulleys | Flywheels | Grid pulleys | Timing belt pulleys | Rubberized Pulleys | Split pulleys | Aluminium pulley



### Supplies for drive belts

TaperLock clamping bushes | Motor mounting systems | V-belts / Drive belts | V-belt metrology | Rubber suspension units  
Oscillating mountings | Tensioner devices | Foundation blocks | Shafts and rolls

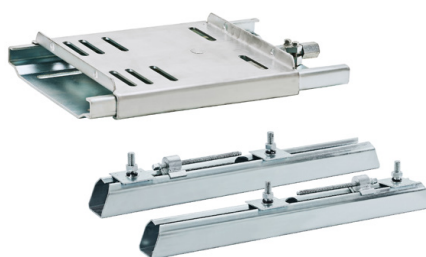
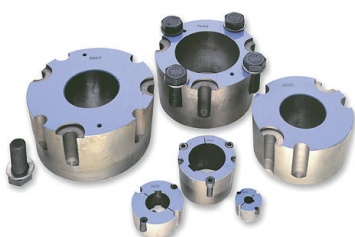

**More information required?**

[www.luetgert-antriebe.de](http://www.luetgert-antriebe.de)



Lütgert & Co. GmbH  
Friedrichsdorfer Straße 48  
33335 Gütersloh | Germany

Phone: +49 5241 7407-0  
vertrieb@luetgert-antriebe.de  
www.luetgert-antriebe.de

MADE IN GERMANY